

# Secure Entry Client

**NCP**

SECURE COMMUNICATIONS ■



# **Secure Entry Client**

(WIN32)  
Version 8.30  
April 2006

With Appendix about Mobile Computing, Domain Logon and NCP Services

**Disclaimer**

Considerable care has been taken in the preparation and publication of this manual, errors in content, typographical or otherwise may occur. If you have any comments or recommendations concerning the accuracy, then please contact NCP as desired.

NCP makes no representations or warranties with respect to the contents or use of this manual, and explicitly disclaims all expressed or implied warranties of merchantability or use for any particular purpose. Furthermore NCP reserves the right to revise this publication and to make amendments to the content, at any time, without obligation to notify any person or entity of such revisions and changes.

**Copyright**

This manual is the sole property of NCP and may not be copied for resale, commercial distribution or translated to another language without the express written permission of NCP engineering GmbH, Dombühler Str. 2, D - 90449 Nürnberg, Germany.

**Trademarks**

All trademarks or registered trademarks appearing in this manual belong to their respective owners.

© 2006 NCP engineering GmbH. All rights reserved.

Total production of this manual:  
Michael Lösel  
Documentation + Publication  
ml-service@t-online.de  
Pirckheimerstraße 47  
D-90408 Nürnberg  
Germany



SECURE COMMUNICATIONS ■

Network  
Communications  
Products engineering GmbH

GERMANY  
Headquarters:  
Dombühler Straße 2  
D-90449 Nürnberg  
Tel.: +49-911-99680  
Fax: +49 - 911 - 9968 299  
Internet <http://www.ncp.de>  
E-mail: [info@ncp.de](mailto:info@ncp.de)

**Support**

NCP offers support for all international users by means of Fax and Internet Mail.

**Fax Hotline Number**

+49 911 99 68 458

**Internet Mail Address**

support@ncp.de

When contacting NCP with your problems or queries please include the following information:

- exact product name
- serial number
- Version number
- Accurate description of your problem
- Any error message(s)

NCP will do its best to respond as soon as possible, but we do not guarantee a fixed response period.

# Contents

<b>1. Overview</b>	<b>13</b>
1.1 Using this manual	13
1.2 NCP Secure Entry Client – Universal IPSec Client	14
1.3 Secure Entry Client	15
Technical Data	16
1.4 Secure Entry CE Client	18
Technical Data	18
<b>2. Installation</b>	<b>21</b>
2.1 Installation Prerequisites	22
System Requirements	22
Remote Destination	22
Local System	22
Prerequisites for Strong Security	25
2.2 Installing the Client Software	27
2.2.1 Installing from a hard disk (e.g. 30 day limited test version)	27
2.2.2 Installing from CD	28
2.2.3 Installing from removable disk	28
2.2.4 User defined Installation and Completion under Win 98/ME	32
2.2.5 User defined Installation and Completion under Win NT/2000/XP	36
2.2.6 Using the Client Software under Windows NT/2000/XP	39
2.3 Initial Configuration Assistant	40
2.4 Updateing and Uninstalling	42
2.5 Upgrade to the Secure Enterprise Client	43
<b>3. Client Monitor</b>	<b>45</b>
3.1 The Client Monitor User Interface	46
3.1.1 Operating and Display Field	46
3.1.2 The Apperance of the Monitors	47
Modification of the Interface	47
3.1.3 Status displays	48
Smart Card	48
PIN status	48
Endpoint Policy	48
Firewall option	48
Friendly Net Detection	49
EAP Status	49
3.1.4 Dialing-up und selecting the Profile	50
<b>4. Using the Client Monitor</b>	<b>51</b>
4.1 Connection	52
4.1.1 Connect	53

4.1.2	Disconnect . . . . .	53
4.1.3	HotSpot Logon . . . . .	53
4.1.4	Connection Info . . . . .	54
	Time Online . . . . .	54
	Timeout . . . . .	54
	Direction . . . . .	54
	Speed . . . . .	54
	Multilink . . . . .	54
	Media Type . . . . .	55
	Compression . . . . .	55
	Encryption . . . . .	55
	Key exchange . . . . .	55
	Rx and Tx Bytes . . . . .	55
4.1.5	Available Communication Media . . . . .	55
4.1.6	Certificates . . . . .	56
	View Issuer Certificate . . . . .	56
	View Client Certificate . . . . .	57
	View incoming Certificate . . . . .	57
	Display CA Certificates . . . . .	58
	Display and analysis of extensions certificates . . . . .	58
	Display of extensions . . . . .	59
	Extension checks . . . . .	60
4.1.7	Enter PIN . . . . .	61
	Safeguarding PIN Use . . . . .	62
4.1.8	Reset PIN . . . . .	62
	PIN State Symbol Visible in the Client Monitor. . . . .	62
	PIN Handling after Logoff or Sleep Mode . . . . .	62
	Displaying ACE Server Messages for RSA-Token . . . . .	62
4.1.9	Change PIN . . . . .	63
4.1.10	Call Control Statistics . . . . .	64
4.1.11	Call Control Reset . . . . .	64
4.1.12	Exit (Disconnect the Monitor) . . . . .	65
4.2	Configuration . . . . .	66
4.2.1	Profile Settings . . . . .	67
	Entries in the profile settings . . . . .	67
4.2.2	Firewall Settings . . . . .	70
	Firewall properties . . . . .	71
	Configuration of the firewall settings . . . . .	71
	Configurationfield Basic Settings . . . . .	72
	Disable Firewall . . . . .	73
	Basic locked settings (recommended) . . . . .	73
	Basic open settings . . . . .	73
	Configurationfield Firewall Rules . . . . .	74
	Creating a firewall rule . . . . .	74
	Firewall rule / General . . . . .	75
	Firewall rule / Local . . . . .	77
	Firewall rule / Remote . . . . .	78
	Firewall rule/ Applications . . . . .	80
	Configurationsfield Friendly Networks . . . . .	81

	Automatic detection of Friendly Nets . . . . .	82
	Friendly Net Detection via TLS . . . . .	82
	Configurationsfield Options . . . . .	83
	Configurationsfield Logging . . . . .	84
4.2.3	WLAN Settings . . . . .	85
	Integrated WLAN configuration for Windows 2000/XP . . . . .	85
	Search networks . . . . .	85
	WLAN Profiles . . . . .	86
	Statistics . . . . .	88
4.2.4	Outside Line Prefix . . . . .	89
4.2.5	Certificates   Configuration . . . . .	90
	User Certificate   Configuration . . . . .	91
	Certificate . . . . .	91
	Smart Card Reader . . . . .	92
	Port . . . . .	92
	Certificate Selection . . . . .	92
	PKCS#12 File Name . . . . .	93
	PKCS#11 Module . . . . .	93
	Do not disconnect when Smart Card is removed . . . . .	94
	PIN request at each manual connect . . . . .	94
	PIN Policy . . . . .	95
	Certificate renewal . . . . .	95
4.2.6	Call Control Manager   Configuration . . . . .	96
	External Applications . . . . .	96
	Call Control . . . . .	97
4.2.7	EAP Settings . . . . .	98
4.2.8	Logon Options . . . . .	99
	Logon . . . . .	99
	Logoff . . . . .	100
	External applications . . . . .	100
	Options . . . . .	101
4.2.9	Configuration Locks . . . . .	102
	General   Configuration Locks . . . . .	102
	Profiles   Configuration Locks . . . . .	103
	General rights . . . . .	103
	Visible profile parameter fields . . . . .	103
4.2.10	Profile Import . . . . .	103
4.2.11	Profile Settings Backup . . . . .	104
	Create . . . . .	104
	Restore . . . . .	104
4.3	Log . . . . .	105
4.4	Window . . . . .	107
	4.4.1 Show Profiles . . . . .	107
	4.4.2 Show Buttons . . . . .	108
	4.4.3 Show Statistics . . . . .	108
	4.4.4 Always on top . . . . .	108
	4.4.5 Autostart . . . . .	109
	4.4.6 Minimize when closing . . . . .	109
	4.4.7 Minimize when connected . . . . .	110



4.4.8	Language	110
4.5	Help	111
4.5.1	License Data and Activation	111
4.5.2	Search new Updates	112
4.5.3	Info	112
4.6	Licensing	113
4.6.2	Test Version Validity Period	114
4.6.2	Software Activation	115
	Online Variant	116
	Offline Variant	118
4.7	Updates	125
4.7.1	Software Updates	125
<b>5.</b>	<b>Configuration Parameters</b>	<b>127</b>
5.1	Profile Settings	128
5.1.1	Basic Settings	130
	Profile name	131
	Connection type	131
	VPN to IPsec correspondent:	131
	Internet connection without VPN:	131
	Communication medium	131
	ISDN:	131
	Modem:	131
	LAN (over IP):	132
	xDSL (PPPoE)	132
	xDSL (AVM – PPP over CAPI)	132
	GPRS / UMTS	132
	PPTP	132
	WLAN	133
	Ext. Dialer	133
	Automatic media detection	134
	Use this profile after every system reboot	134
	Use this phonebook entry after every system reboot	135
	Use Microsoft RAS-Dialer	135
5.1.2	Dial-Up Network	136
	Username	137
	Password	137
	Save password	137
	Destination phone number	137
	Alternate destination phone numbers	138
	RAS script file	138
5.1.3	HTTP Logon	139
	Username   HTTP Logon	140
	Password   HTTP Logon	140
	Save Password   HTTP Logon	140
	HTTP Authentication Script   HTTP Logon	140
5.1.4	Modem	141
	Modem	142
	COM Port	142

	Baud Rate . . . . .	142
	Release Com Port . . . . .	142
	Modem Init. String . . . . .	143
	Dial Prefix . . . . .	143
	APN . . . . .	143
	SIM PIN . . . . .	143
5.1.5	Line Management . . . . .	144
	Connection Mode . . . . .	145
	Inactivity Timeout . . . . .	145
	PPP Multilink . . . . .	146
	Multilink Threshold . . . . .	146
	EAP authentication . . . . .	147
	HTTP authentication . . . . .	147
5.1.6	IPSec General Settings . . . . .	148
	Gateway . . . . .	149
	IKE Policy . . . . .	149
	IPSec Policy . . . . .	150
	Exch. mode . . . . .	150
	PFS group . . . . .	150
	Policy lifetimes . . . . .	151
	Duration . . . . .	151
	Policy editor . . . . .	151
	IKE Policy (edit) . . . . .	152
	Policy Name   IKE Policy . . . . .	153
	Authentication   IKE Policy . . . . .	153
	Encryption   IKE Policy . . . . .	153
	Hash   IKE Policy . . . . .	153
	DH Group   IKE Policy . . . . .	153
	IPSec Policy (edit) . . . . .	154
	Policy Name   IPSec Policy . . . . .	154
	Protocol   IPSec Policy . . . . .	154
	Transformation (ESP)   IPSec Policy . . . . .	154
	Transformation (Comp)   IPSec Policy . . . . .	154
	Authentication   IPSec Policy . . . . .	154
5.1.7	Advanced IPSec Options . . . . .	155
	Use IP compression (LZS) . . . . .	156
	Disable DPD (Dead Peer Detection) . . . . .	156
	Force UDP Encapsulation (Port 4500) . . . . .	156
5.1.8	Identities . . . . .	157
	Type   Identity . . . . .	158
	ID   Identity . . . . .	158
	Use pre-shared key . . . . .	158
	Use extended authentication (XAUTH) . . . . .	158
	Username   Identity . . . . .	159
	Password   Identity . . . . .	159
	Use access data from configuration . . . . .	159
5.1.9	IP Address Assignment . . . . .	160
	Use IKE Config Mode . . . . .	161
	Use local IP address . . . . .	161

Manual IP address . . . . .	161
DNS/WINS . . . . .	161
DNS server . . . . .	161
WINS server . . . . .	161
Domain Name . . . . .	161
5.1.10 Remote Networks . . . . .	162
Network addresses   Remote Networks . . . . .	163
Subnet masks . . . . .	163
Apply tunneling security for local networks . . . . .	163
5.1.11 Certificate Check . . . . .	164
Incoming certificate's subject . . . . .	165
Incoming certificate's Issuer . . . . .	165
Issuer's certificate fingerprint . . . . .	166
Use SHA1 fingerprint . . . . .	166
Further certificate checks . . . . .	166
5.1.12 Link Firewall . . . . .	169
Enable Stateful Inspection . . . . .	170
Only communication within the tunnel permitted . . . . .	170
Enable NetBios over IP . . . . .	170
If Microsoft's dialer in use only communication within the tunnel is permitted . . . . .	170
<b>6. Establishing a Connection . . . . .</b>	<b>171</b>
Establishing a Connection to the destination system . . . . .	171
Connect . . . . .	171
Client Logon . . . . .	174
Passwords and User Names . . . . .	175
User ID for NAS Dial-Up . . . . .	175
User Name and Password for Extended Authentication . . . . .	176
Disconnection and error . . . . .	177
Disconnect . . . . .	177
Disconnect (the Monitor) . . . . .	178
<b>7. Examples and Explanations . . . . .</b>	<b>179</b>
7.1 IP Functions . . . . .	180
7.1.1 IP Network Devices . . . . .	180
7.1.2 IP Address Structure . . . . .	180
7.1.3 Subnet Masks . . . . .	182
Standard masks . . . . .	183
Reserved addresses . . . . .	184
7.1.4 Using IP Addresses: . . . . .	184
7.2 Security . . . . .	185
7.2.1 IPSec – Overview . . . . .	185
IPSec – General Functional Description . . . . .	185
7.2.2 Firewall Settings . . . . .	187
7.2.3 SA Negotiation and Policies . . . . .	188
Phase 1 (IKE Policy) . . . . .	188
Phase 2 (IPSec Policy) . . . . .	188

Control Channel and SA Negotiation . . . . .	189
IKE Modes . . . . .	190
7.2.4 IPsec Tunneling . . . . .	192
Implemented Algorithms for Phase 1 and 2: . . . . .	192
Supported authentication methods for phase 1 (IKE policy) . . . . .	192
Supported symmetric encryption algorithms (phase 1 & 2) . . . . .	192
Supported asymmetric encryption algorithms (phase 1 & 2) . . . . .	192
Supported hash algorithms . . . . .	193
Additional phase 2 support . . . . .	193
Default mode proposals . . . . .	194
7.2.5 Further Configuration . . . . .	196
Basic configurations depending on the IPsec gateway . . . . .	196
Gateway does not support XAUTH . . . . .	196
Gateway supports IKE config mode . . . . .	196
Gateway does not support IKE config mode . . . . .	196
7.2.6 IPsec ports for connection establishment and data traffic . . . . .	198
7.3 Certificate Checks . . . . .	199
7.3.1 Selection of the CA Certificates . . . . .	199
7.3.2 Check of Certificate Extensions . . . . .	199
extendedKeyUsage . . . . .	200
subjectKeyIdentifier / authorityKeyIdentifier . . . . .	200
7.8.3 Checking Revocation Lists . . . . .	200
7.4 Stateful Inspection Technology for the Firewall- Settings . . . . .	201
<b>Abbreviations and Technical Terms . . . . .</b>	<b>205</b>
<b>Appendix: Mobile Computing via GPRS/UMTS and</b>	
<b>Domain Login via NCP Gina . . . . .</b>	<b>A 1</b>
<b>Appendix: Secure Client Services . . . . .</b>	<b>A23</b>
<b>Index . . . . .</b>	<b>219</b>



# 1. Overview



This manual describes Installation, Configuration, Features and User Interface of the NCP Secure Entry Client and its Components

The NCP Secure Client Software works according to the principle of Ethernet LAN emulation and supports the routable protocol TCP/IP.

Additional information on upgrades and product variants are available on the NCP website: <http://www.ncp.de>

## 1.1 Using this manual

The structure of this manual is presented below to help you quickly find what you need in this documentation.

The manual is subdivided into seven larger sections that offer step-by-step descriptions, or that describe the structure of the graphic user interface according to the respective object. Two appendices providing additional information and definitions of specialized terms follow these sections.

1. Product overview with brief description of the performance range of the software
  2. Installation instructions
  3. Description of the graphic user interface
  4. Description of the configuration possibilities in the monitor
  5. Description of the parameters listed in the telephone book
  6. Description of a connection establishment
  7. Examples and explanations, particularly for IPsec
- Appendices with a glossary (abbreviations and terms) and an index



Cross references appear in the text in parenthesis and cite the reference with the title, or after a comma, with the subtitle. An exclamation mark in the margin indicates that the text so marked is of particular significance.



Naturally the software also offers context-sensitive help.

## 1.2 NCP Secure Entry Client – Universal IPsec Client

The NCP Secure Entry Client can be used in any VPN environment. The client communicates on the basis of the IPsec standard (see →Examples and explanations, Security, IPsec) with the gateways provided by a wide variety of vendors\* and is the alternative to the uniform IPsec client technology offered on the market. The Secure Entry Client has additional features that introduce the user into a holistic remote access VPN solution.

### *The NCP Secure Entry Client offers:*

- Support of all major operating systems
- Dial-in over all transmission networks
- Compatibility with VPN gateways from a wide variety of vendors\*
- Integrated personal firewall for more security
- Dialer protection (no misuse by third parties)
- Higher speed in the ISDN (channel-bundling)
- Saving telephone charges (charges and connection management)
- Convenient operation (graphic interface)
- Central management\*\*

\*) *Compatibility list available on the NCP website [www.ncp.de](http://www.ncp.de)*

\*\*\*) *optional*

## 1.3 Secure Entry Client

The NCP Secure Entry Client communicates with VPN gateways supplied by a wide range of manufacturers, on the basis of the IPSec standard. This involves client software that can be used as an alternative to the software clients offered on the market in the firewall and router area.

The Secure Entry Client is differentiated from other IPSec clients through its feature set and through its software architecture.

Secure Entry Client advantages:

- Support of all major Windows operating systems, including Windows CE
- Dial-in over all public data transmission networks
- Compatibility with virtually all VPN gateways on the market
- Integrated personal firewall
- Dialer Protection
- Intelligent Line Management for minimizing transmission costs and increasing transparency (Charge Manager)
- Channel bundling for high transmission speed in ISDN
- Graphic user interface

Like all NCP Secure Communications Products, the Secure Entry Client supports the use of digital certificates in a Public Key Infrastructure (PKI). An upgrade to the NCP Secure Enterprise Solution with high-performance, central management is available as an option.



## *Technical Data*

### ■ LAN-Emulation

Ethernet adapter with NDIS interface

### ■ PC Operating Systems

Windows 98se, Windows NT (V4.0 SP5), Windows 2000, Windows ME, Windows XP Prof.

### ■ Network Protocols

- IP
- IPSec VPN: Supports Pre-Shared Key and certificates, central configuration of IPSec proposals, e.g. the central VPN gateway determines the policies (for IKE, IPSec Phase 2) for the Secure Entry Client.
- IPSec in accordance with RFC 2401-2409, additionally the drafts (XAUTH, IKE-Config, DPD, NAT-T, IP-Comp) are supported for optimization in Remote Access environments (see RFCs and Drafts below\*).
- EAP-MD5, EAP-TLS Extensible Authentication Protocol, extended authentication relative to switches and access points (Layer 2)

### ■ Encryption

- Triple DES (128, 192 Bit)
- Blowfish (128 Bit)
- AES (128, 192, 256 Bit)
- RSA (1024, 2048 Bit)
- Hash processes
- SHA1 (Secure Hash Algorithm 1)
- MD5 (Message Digit 5)

### ■ Personal Firewall

- IP-NAT Network Address Translation
- Stateful Inspection
- Filter rules assigned to applications and certain connections
- Filter rules assigned to certain protocols, ports and addresses
- Identification of friendly networks
- Automatic hotspot logon
- Extensive logging options

### ■ Filtering

IP Broadcasts, Netbios over IP

## ■ PKI

- Public Key Infrastructure in accordance with X.509 v.3 standard, Entrust (Entrust Ready)
- Smartcards: PKCS#11, TCOS 1.2 and 2.0–CardOS M4 (via CT-API or PC/SC)
- Soft certificate: PKCS#12
- PIN policy: Administrative specification for PIN entry of any complexity
- Revocation lists: Checking the CRL (Certificate Revocation List) and ARL (Authority Revocation List)
- Certificate control: Verification and notification of a certificate's validity period

## ■ One Time Password

convenient entry by separating PIN and password (RSA-ready)

## ■ DynDNS (Dynamic DNS)

Accessing the central VPN gateway with changing public IP addresses, query of the current IP address via a public DynDNS server

## ■ IP Adress Allocation

DHCP Dynamic Host Control Protocol

## ■ Point-to-Point Protocols

- PPP over ISDN
- PPP over GSM (V.110)
- PPP over PSTN (Modem)
- PPP over Ethernet (xDSL)
- PPP LCP Link Control Protocol
- PPP IPCP IP Control Protocol
- PPP MLP Multilink Protocol
- PPP Call Back negotiation in the LLCP
- PPP PAP Password Authentication Protocol
- PPP CHAP Challenge Handshake Authentication Protocol

## ■ Dialer

- NCP Dialer
- alternatively: Microsoft RAS-Dialer for ISP access via dial-in script

## ■ Line Management

Short hold, timeout (time-controlled and charge-controlled)

## ■ Channel Bundling in ISDN

Dynamic, freely configurable threshold value

- **Client Monitor**

Configuration of the teleworkstation, connection control and monitoring

- **Connection Manager**

For international access. Support for: Gric, Infonet, UUNet

## 1.4 Secure Entry CE Client

### *Technical Data*

- **LAN Adapters**

- Ethernet-Adapter with NDIS Interface
- Wireless LAN-Adapter

- **Operating Systems**

Mobile end device: Windows CE 3.0 (Handheld PC 2000, Pocket PC 2002), Windows CE.net 4.2 (Windows Mobile 2003 for Pocket PC)

Configuration PC: Windows 98se/ NT 4.0 from SP5/ 2000/XP

- **Network Protocols**

- IP
- IPSec-VPN: support of Pre-Shared-Key and certificates, central configuration of IP-Sec proposals, e.g. the central VPN gateway determines the policies (for IKE, IPSec Phase 2) for the Secure Entry Client.
- IPSec in accordance with RFC 2401-2409, additionally the drafts (XAUTH, IKE-Config, DPD, NAT-T, IP-Comp) are supported for optimization in Remote Access environments (see RFCs and Drafts below\*).

## ■ Encryption

- Triple DES (128, 192 Bit)
- Blowfish (128 Bit)
- AES (128, 192, 256 Bit)
- RSA (1024, 2048 Bit)

## ■ Hash Process

- SHA1 (Secure Hash Algorithm 1)
- MD5 (Message Digit 5)

## ■ Firewall Functionalities

- IP-NAT Network Address Translation
- LAN adapter protection PC protection against access from other systems at VPN connection

## ■ Filtering

- IP broadcasts
- Netbios over IP

## ■ PKI

- Public Key Infrastructure in accordance with the X.509 v.3 standard
- Smart cards: TCOS 1.2 and 2.0 – CardOS M4 (PC/SC)
- Soft certificate: PKCS#12

## ■ IP Adress Allocation

DHCP Dynamic Host Control Protocol

## ■ Point-to-Point Protocols

- PPP LCP Link Control Protocol
- PPP IPCP IP Control Protocol
- PPP CCP Compression Control Protocol
- PPP PAP Password Authentication Protocol
- PPP CHAP Challenge Handshake Authentication Protocol
- PPP ECP Encryption Control Protocol

## ■ Compression Process

Stac

## ■ Line Management

Short Hold, Timeout (time-controlled)

## ■ Client Monitor

- The PDA is configured on a standard PC via the Client Monitor
- The “PDA Monitor” is used for status display and for dialing the destination

## ■ Dialer

- NCP-Dialer
- Microsoft RAS-Dialer

## ■ Options

- Central NCP Secure Enterprise VPN/PKI Gateway
- Upgrade to NCP Secure Enterprise Solution with central Management Tool and High Availability Services

## ■ RFCs and Drafts

- RFC 2401– Security Architecture for the Internet Protocol
- RFC 2403 – The Use of HMAC-MD5-96 within ESP and AH
- RFC 2404 – The Use of HMAC-SHA-1-96 within ESP and AH
- RFC 2406 – IP Encapsulating Security Payload (ESP)
- RFC 2407 – The Internet IP Security Domain of Interpretation for ISAKMP
- RFC 2408 – Internet Security Association and Key Management Protocol (ISAKMP)
- RFC 2409 – The Internet Key Exchange (IKE)
- RFC 3947 – Negotiation of NAT Traversal in IKE
- RFC 3498 – UDP Encapsulation of IPSEC ESP packets
- DRAFT – Draft-beaulieu-ike-xauth-05 (XAUTH)
- DRAFT – Draft-dukes-ike-mode-cfg-02 (IKECFG)
- DRAFT – Draft-ietf-ipsec-dpd-01 (DPD)
- DRAFT – Draft-ietf-ipsec-nat-t-ike-01 (NAT-T)
- DRAFT – Draft-ietf-ipsec-nat-t-ike-02 (NAT-T)
- DRAFT – Draft-ietf-ipsec-nat-t-ike-03 (NAT-T)
- DRAFT – Draft-ietf-ipsec-nat-t-ike-05 (NAT-T)
- DRAFT – Draft-ietf-ipsec-udp-encaps-06 (UDP-ENCAP)

## 2. Installation

A Setup program performs the installation of the Client Software quickly and smoothly. The following text describes the procedures for installing the Client Software under Windows 98/ME and Windows NT/2000/XP.



**Prior to executing Setup be sure that the following prerequisites are fulfilled.**

## 2.1 Installation Prerequisites

### System Requirements

In order to be able to communicate with the Client Software it is essential to have either Microsoft Windows 98, Windows ME, Windows NT (4.0 or later) with the service pack 5.0 (or later), Windows 2000 or Windows XP installed on your PC (min. 32 MB RAM). During the installation you are asked to have your or disks ready, as these will be needed for updating your PC's driver database files. Please insert these when prompted to do so.

### Remote Destination

The parameters of the remote destination must be entered in the profile settings. In order to communicate with the remote destination it must support one of the following media types: ISDN, PSTN (analog modem), LAN over IP or PPP over Ethernet.

### Local System



One of the following communication devices and its respective drivers must be properly installed on the Client Software PC.

#### ■ ISDN adapter (ISDN)

The device (e.g. internal or external adapter) must support the ISDN CAPI 2.0 Kernel Mode standard. When using PPP Multilink the software can bundle up to 8 ISDN B-Channels. Any ISDN device supporting the ISDN CAPI 2.0 can be used. Please check your device to be sure that such a driver is available. The Client Software does not support TAPI based ISDN devices.

#### ■ Analog Modem (Modem)

The Client Software can communicate with any industry standard analog PC modem, provided that it and the modem drivers have been properly installed and the modem initialization string and the COM port definition for the modem is correct. The modem has to support Hayes AT commands.

Mobile (cellular) telephones can also be used for data communication, after the associated software has been installed that presents itself to the client precisely as if it were an analog modem. The serial interface, IR (infrared) interface, or Bluetooth can be used as interface between mobile phone and PC. The opposite side must have the appropriate dial-in platform depending on the transfer rate (GSM, v.110, GPRS or

HSCSD). The initialization string in the Secure Client modem configuration must be obtained from the ISP or the manufacturer of the mobile (cellular) phone.

### ■ **LAN adapter (LAN over IP)**

When the communication medium LAN has been defined the Client Software may be used as a IPsec client in a LAN that communicates across a LAN network and associated router to a central site VPN Gateway. When defined as a LAN Client, the Client Software can also be used as a VPN or VPN/PKI plugin for Microsoft's RAS (Dial-Up Network) client.

### ■ **xDSL Broadband Device (PPPoE)**

Cable modems, splitters (e.g. for ADSL), etc. can be used in conjunction with PPP over Ethernet (PPPoE), which is supported by the Client Software.

### ■ **xDSL (AVM - PPP over CAPI)**

If an AVM Fritz DSL card is to be used then this communication medium may be selected. AVM specific initialization strings may be entered in the field "Destination phone number" ("Dial-Up Network" group) for the connection.

It is recommended to use the standard setting "xDSL (PPPoE)" with Windows operating systems as this provides direct communication over the network interfaces.

No additional network card is necessary with the AVM Fritz! DSL card.

### ■ **Multifunction Card (GPRS/UMTS)**

If you are using a multi-function card, special features of the mobile computing can be used depending on the card characteristics (see the appendix of the handbook "Mobile Computing). Due to the direct support of the multi-function card for UMTS/GPRS/WLAN through the Secure Client, installation of management software from the card implemented, is not necessary. The VPN connection is established via the integrated NCP Dialer independent of the Microsoft data communications network.

Currently supported multi-function cards:

- T-Mobile Multimedia NetCard
- Vodafone Mobile Connect Card
- KPN Mobile Connect Card
- T-Mobile DSL card 1800

### ■ **WLAN adapter under Windows 98/NT (LAN over IP)**

Adapters for a wireless LAN (WLAN adapter) are handled exactly like normal LAN adapters. "LAN (over IP)" must also be selected for WLAN. In this case the management tool of the WLAN card, or the Microsoft tool must be activated.



## ■ WLAN adapter under Windows 2000/XP (WLAN)

Under Windows 2000/XP the WLAN adapter can be operated with the link type “WLAN”. In the monitor menu the special “WLAN settings” menu item is displayed where the access data for the wireless network can be saved in a profile. If this “WLAN configuration” is activated, then the management tool of the WLAN card, or the Microsoft tool must be deactivated. (Alternatively the management tool of the WLAN card or the Microsoft tool can be used as well.)

If the link type WLAN is set for the destination system in the phonebook, then under the graphic field of the Client Monitor an additional area is shown where the field strength and the WLAN network are displayed.



Please read the description of the parameters “Link Type” in the section “Configuration parameters / Profile Settings”.

## ■ Automatic Media Detection

If various link types could be used, the client detects automatically which link type actually can be used and selects the fastest one.

On the basis of a pre-configured destination system, those link types that are currently available for the Client PC are detected and implemented, and if multiple alternative transmission paths are available, the fastest will be selected automatically. The link type priority is specified in the following sequence in a search routine: 1. LAN, 2. WLAN, 3. DSL, 4. UMTS/GPRS, 5. ISDN, 6. MODEM.

The configuration is executed in the phonebook with the link type “Automatic media detection” under “Destination system”. If desired, all destination systems for the VPN gateway that are pre-configured for this Client PC can be assigned to this automatic media detection. This renders manual selection of a medium (WLAN, UMTS, LAN, DSL, ISDN, MODEM) from the profile entries superfluous. Input data for the connection to the ISP are transferred from the available profile entries in a manner that is transparent for the user.



Please note the description “Destination System / Link Type”.

## Prerequisites for Strong Security



If you are using the Client Software with certificates (X.509), then the following prerequisites must be fulfilled:

### ■ TCP/IP

The protocol TCP/IP must be installed on your PC.

### ■ Smart Card Reader

The Client Software supports all Smart Card readers that are PC/SC conform. Subsequently such readers will only be entered in the Client Software Smart Card reader list after the Smart Card reader including the associated driver software has been installed on the PC. The Client Software detects the Smart Card reader automatically after the PC has been booted. The Smart Card reader can then be selected as described above and used accordingly.

In order to use the features of the Smart Card, configure the Smart Card by selecting “Configuration →Certificates” in the pull-down menu of the Client Software Monitor. When you insert your Smart Card in the Smart Card reader, you can enter your PIN.

### ■ Smart Card Reader (CT-API conform)

Please note the following instructions when using a Smart Card reader that is CT-API conform:

- The current software includes drivers for the Smart Card readers SCM Swapsmart and SCM 1x0 (PIN Pad reader). These Smart Card readers can be set in the Monitor under “Configuration →Certificates”. If, however, the Smart Card reader does not work with the drivers, which are included in the software, or a Smart Card reader is to be used, which does not show up in the configuration selection of supported readers, then ask the supplier or producer of the Smart Card (or the respective website) reader for the current hardware driver and install it. In this case the client software requires some modifications:
- Use an ASCII editor to edit the NCPPKI.CONF file. You find this file in the WINDOWS\SYSTEM directory (Windows 95/98) or in the SYSTEM32 directory (Windows NT/2000). Enter the name of the connected Smart Card reader as “ReaderName” (xyz) and the name of the installed driver as DLLWIN95 or DLLWINNT respectively. The default name for CT-API conform drivers is CT32.DLL.



Important: Only those drivers that have been appropriately set with “visible = 1” will be displayed in the list!

Modulname	=	SCM Swapsmart (CT-API)	→xyz
DLLWIN95	=	scm20098.dll	→ct32.dll
DLLWINNT	=	scm200nt.dll	→ct32.dll

- After rebooting the PC the new “ReaderName” is displayed in the Monitor under “Configuration →Certificates →Smart Card reader”. Now you select that Smart Card reader.

## ■ Smart Cards

Currently, the following Smart Cards are supported:

- Signtrust
- NetKey 2000
- TC Trust (CardOS M4)
- Telesec PKS SigG

## ■ Soft Certificates (PKCS#12)

Instead of a Smart Card you can also use soft certificates or tokens.

## ■ Smart Cards or Token (PKCS#11)

Drivers in the form of a PKCS#11 library are supplied with the software for the card reader or token. This driver software must first be installed. Then the NCPPKI.CONF file must be edited.

- Edit the NCPPKI.CONF file located in the windows\system directory (Windows 95/98) or system32 directory (Windows NT/2000), with an ASCII editor by entering the name of the connected reader or token (xyz) as “module name”. The name of the DLL must be entered as PKCS#11-DLL. The associated “Slotindex” is manufacturer-dependant (standard = 0).

Important: Only those drivers are visible in the list that have been set to visible with “visible = 1”.



```
Modulname    = xyz
PKCS#11-DLL = Name of the DLL
Slotindex    =
```

- After rebooting the PC the new “ReaderName” is displayed in the Monitor under “Configuration →Certificates →Smart Card reader”. Now you select that Smart Card reader.

## 2.2 Installing the Client Software



The initial installation steps for the Client Software are almost the same for both Windows 98/ME and Windows NT/2000/XP. Please note that there are some differences when installing from a hard disk, CD or removable disk.

### *Installation and Licensing*



First the NCP Secure Entry Client is installed as a test version. If you possess a license, you can enter the license data after a reboot of the software by selecting the monitor menu option “License Info and Activation”. The test version is valid for 30 days. Without software activation or licensing it will no longer be possible to setup a connection after this 30-day period expires. When 10-days validity remain, a message box will be displayed to remind you that the software has not yet been licensed. For licensing the software please refer to the chapter “Licensing” in the handbook.

### *Please note when installing the Software under Windows XP:*

Microsoft Windows XP informs the user as soon as a driver software is being installed which is not licensed by Microsoft. Windows XP runs a Microsoft specific “compatibility test” and warns the user not to install the software. This test does not check the compatibility of the software with Windows XP. Since the client software is not licensed by Microsoft, the warning occurs when the client is installed on a Windows XP machine. What to do:

- You can modify the Windows XP default settings so that any software can be installed without the Microsoft compatibility check. Open the Windows Control Panel and then “System (Properties) - Driver Signing”. Set the install procedure to “Install the software anyway and don’t ask for my approval”!
- You can ignore the warning when installing the client. After the warning pops up you click on “proceed Installation” Windows XP will let you install the client adapter. The installation will not have any negative effect on the operating system.

### 2.2.1 Installing from a hard disk (e.g. 30 day limited test version)



If you want to install the Client Software after downloading it, first extract the data. Extracting the data in directory “Disk1” will be made automatically. Then start the installation with Setup.exe from directory ”DISK1”. All further installation steps are the same as described in the following text under “Installation from removable disk” when the window “Choose Setup Language” appears.

## 2.2.2 Installing from CD

After inserting the CD in the drive of your PC, the welcome window appears on the monitor.

Click on “Install Products” and then select the Client Software version to be installed. All further installation procedures are identical with the installation procedures for installing from removable disk, from the window “Choose Setup Language”.

## 2.2.3 Installing from removable disk

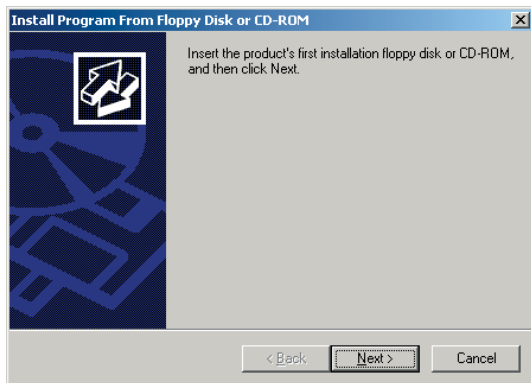

To install the Client Software select in the windows main menu: Start →Settings → Control Panel. Select “Add/Remove Programs” in the Control Panel and then click on the “Install” button.

Insert the removable disk with the Client Software in the PC if you have not already done so and then click “Next”.

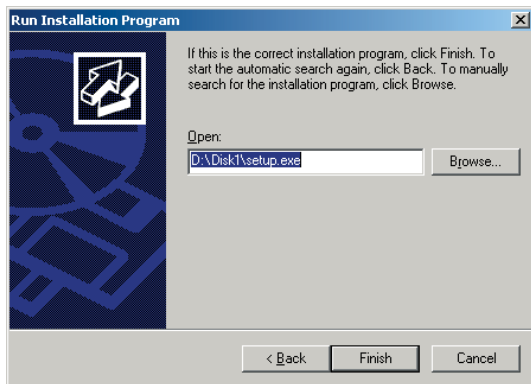

When SETUP.EXE appears click on “Finish”.

→continue next page  
“Choose Setup Language”

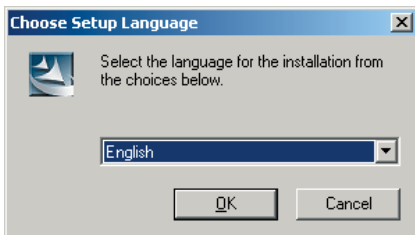

### “Choose Setup Language”

A window appears where you can select the language to be used for the installation and then click “OK”.

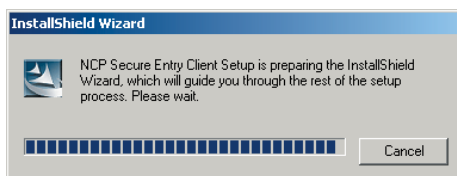

The “Install Shield Assistant” is now started. It will guide you through the installation.

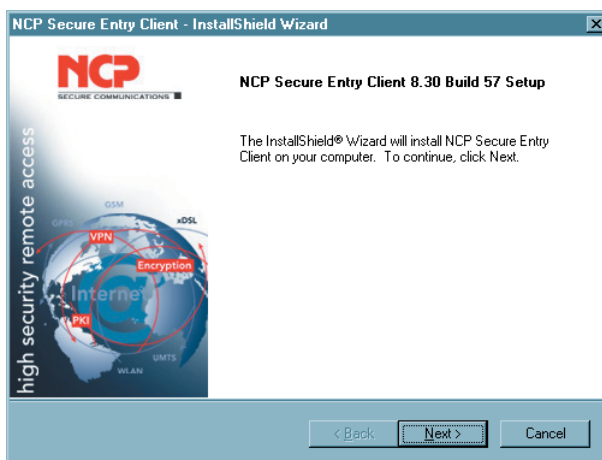

Read the terms of the Welcome window carefully and click on “Next”.

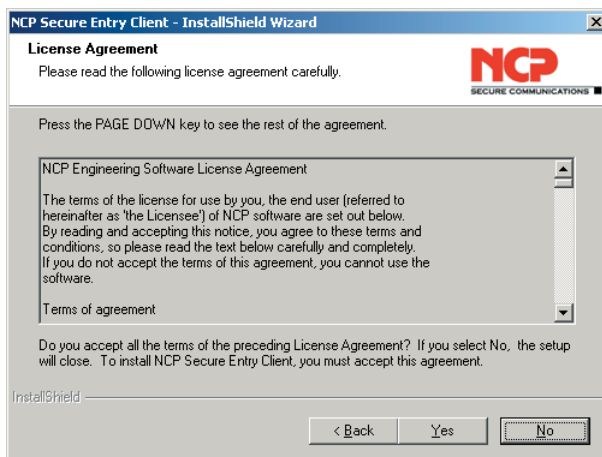

The next window displays the Software Licensed Agreement. In order to proceed with the installation of the licensed version click on “Yes”. Clicking “No” will stop the installation process.

→ *continue next page*

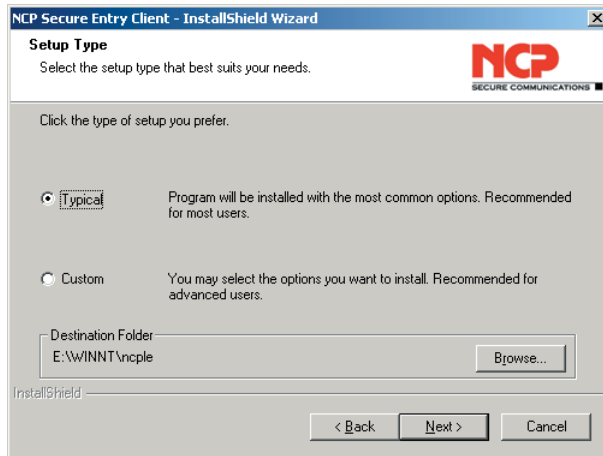

Independently of “Typical” or “Custom” installation you can select any folder for the software installation by clicking on “Browse”. This is particularly important if the user should have no rights on the system root directory.

If you select “**Typical**” in this window the installation will continue automatically and the setup is finished.

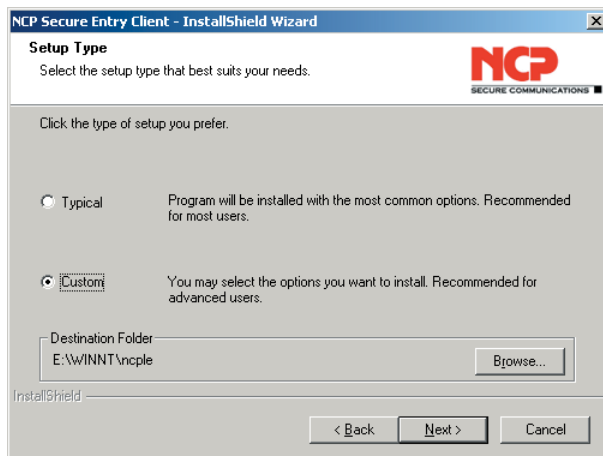

Selecting the “**Custom**” Installation you can define settings according to your requirements.

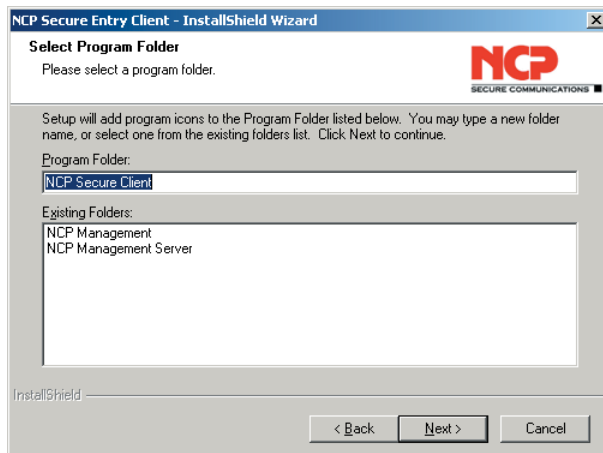

In the following window of the “Custom” installation you define the program folder for the client software. (Default setting “NCP Secure Client”)

→ continue next page

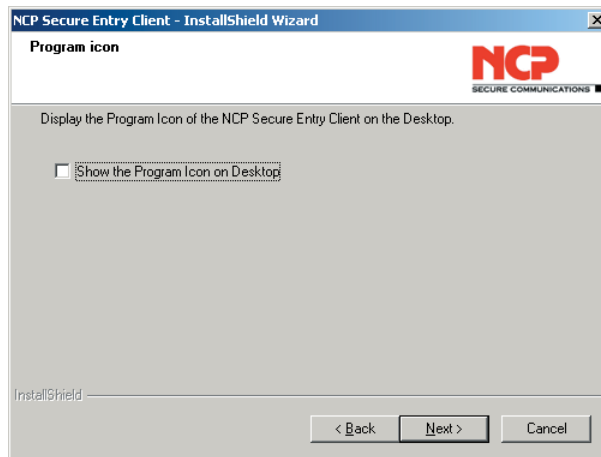

Moreover you can have the program icon displayed on the desktop.

Please contact your system administrator or your internet service provider for additional information about your communication gateway.



**Following are a list of minor differences in the installation procedures for Windows 98/ME and Windows NT/2000/XP.**

→for Windows 98/ME  
continue 2.2.4

→for Windows NT/2000/XP  
continue 2.2.5



## 2.2.4 User defined Installation and Completion under Windows 98/ME

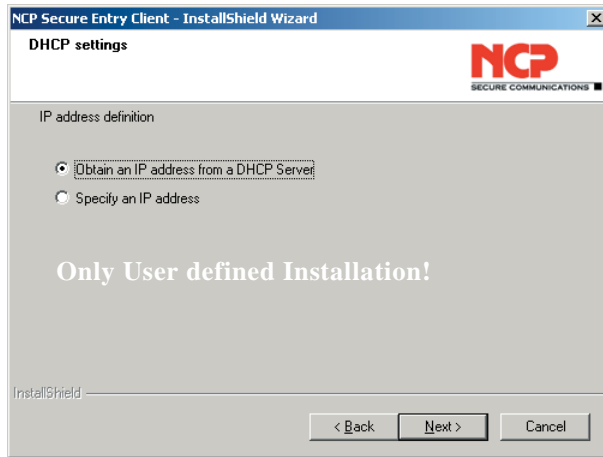

Communication with DHCP (Dynamic Host Control Protocol) means that a temporary IP Address will be assigned automatically for each communication session. If required, click on “Obtain an IP Address from DHCP Server”.

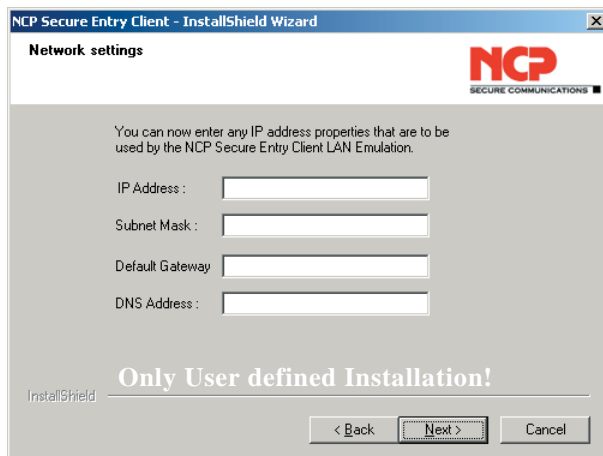

If you “Specify an IP Address”, enter the IP address in this window. Default Gateway: If a network adapter with a Default Gateway is already installed, you will have to delete this Default Gateway Address. It is not possible to have more than one network adapter with a Default Gateway. DNS Address: You should only enter a DNS Address if you have been assigned one from your system administrator or ISP.

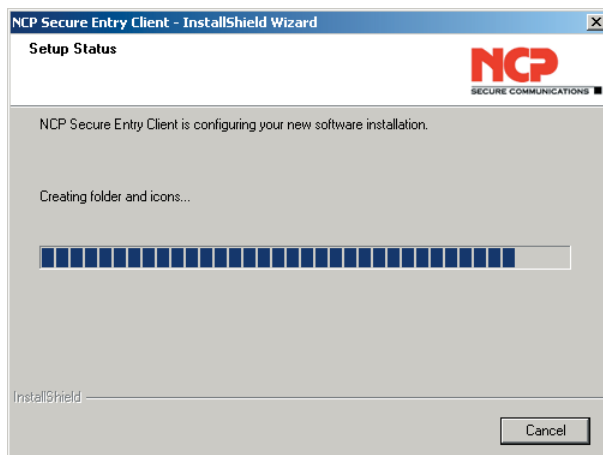

[If you already have the software installed on your PC, this will be detected by the installation program. You will be prompted and asked if you wish to “Update” the current Secure Client or if you wish to cancel the installation (see → “Update and Uninstalling”).] Now the data will be loaded and copied.

*End of User defined Installation!  
→ to complete continue next page*

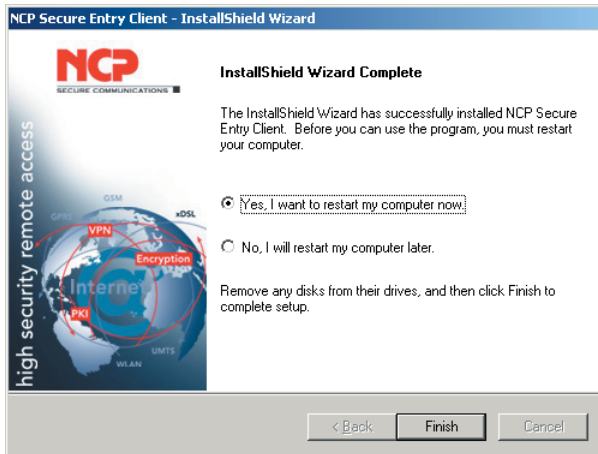

After all data from the CD or Diskette have been loaded, click on “Finish” to complete the setup.

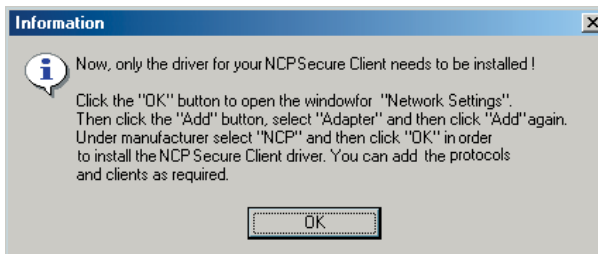

Now you will be prompted to install the driver. To proceed, click on the “OK” button.

→ continue next page

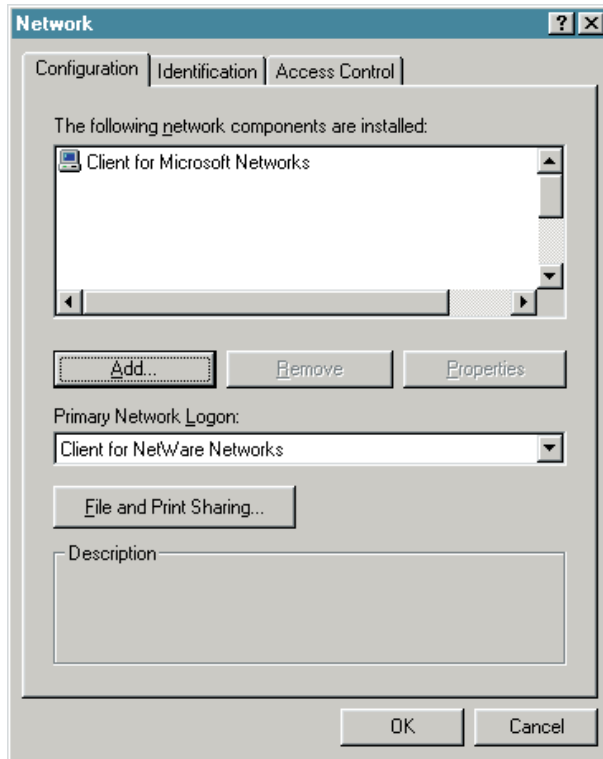

Afer clicking “OK” the Network window will appear. Click on “Add” ...

(Under Windows ME a correspondend dialogue “add hardware” is displayed).

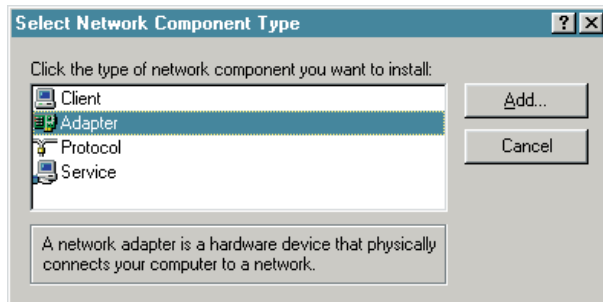

Select Network Component and then click on “Add” again.

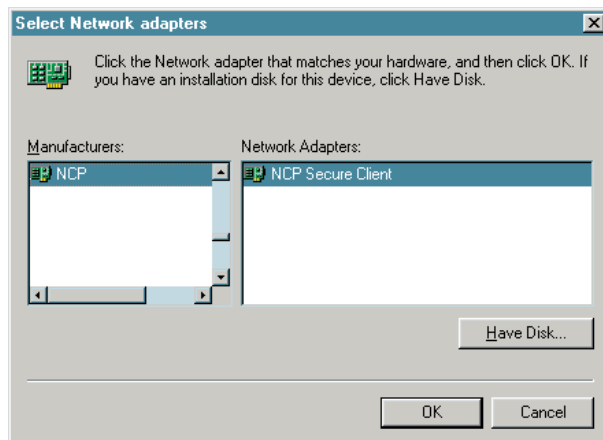

Under “Manufacturer” select NCP and then select the driver “NCP Secure Client” in the window on the right. Click on “OK” in order to install the driver. This completes the installation of the Client Software with setup under Windows 98/ME.

→ continue next page

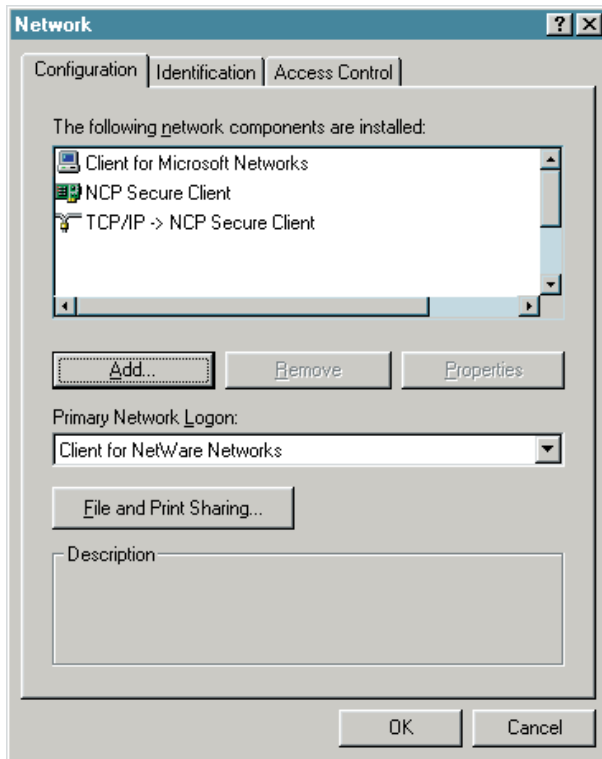

Upon doing so the driver will be installed and displayed in the list of adapters in the Network window. TCP/IP will also be installed and bound to the NCP Secure Client.

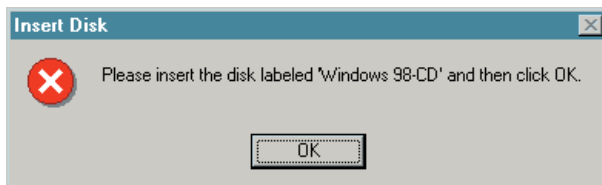

Thereafter it will be necessary to copy files from the operating system in order to update the driver data base.

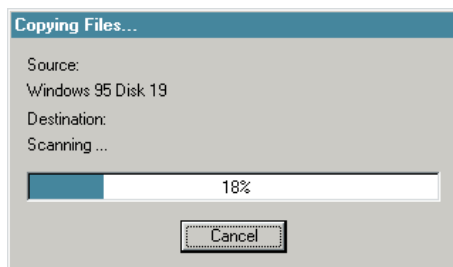

Insert the respective CD or enter the path for the operating system.

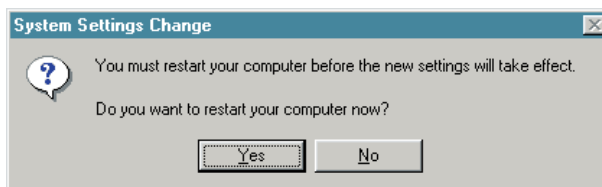

Click "Yes" and wait till you are prompted to reboot your system.

## 2.2.5 User defined Installation and Completion under Windows NT/2000/XP

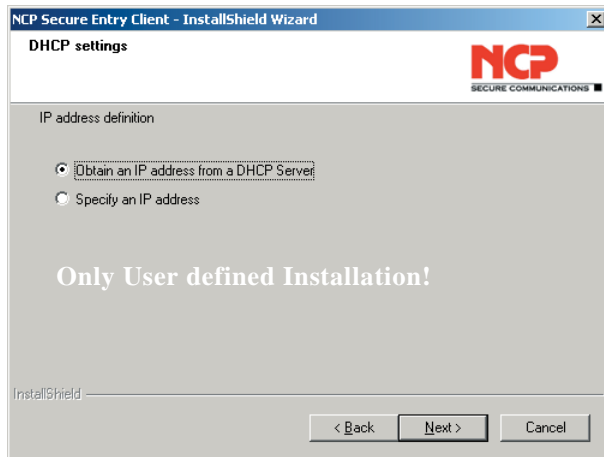

Communication with DHCP (Dynamic Host Control Protocol) means that a temporary IP Address will be assigned automatically for each communication session. If required, click on “Obtain an IP Address from DHCP Server”.

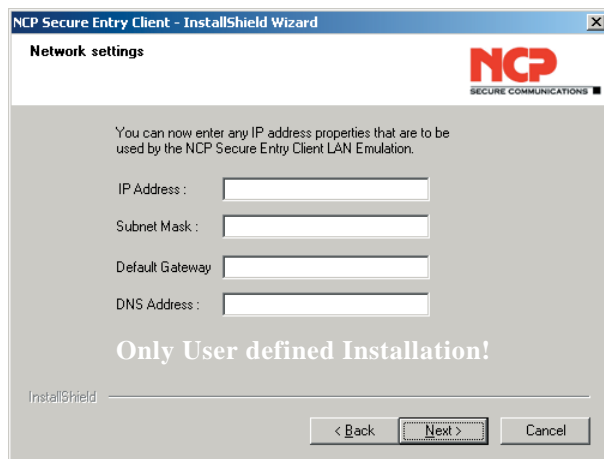

If you “Specify an IP Address”, enter the IP address in this window. Default Gateway: If a network adapter with a Default Gateway is already installed, you will have to delete this Default Gateway Address. It is not possible to have more than one network adapter with a Default Gateway. DNS Address: You should only enter a DNS Address if you have been assigned one from your system administrator or ISP.

→continue next page

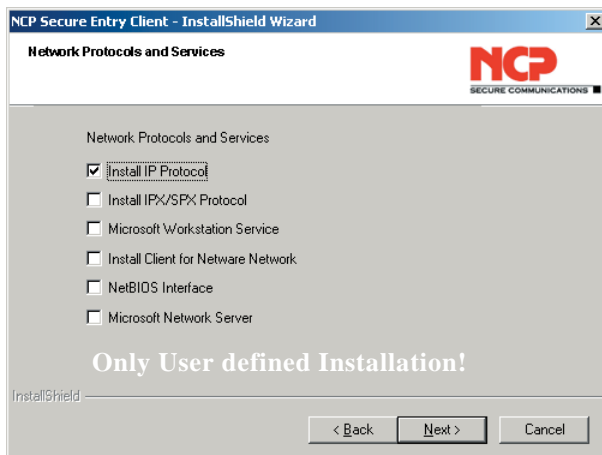

[Under Windows NT you can define any additional protocols and services to be installed. Be sure to have the operating system CD or Diskettes available, as you may need a driver for the installation. Click on “Next” to conclude the User defined Installation.]

*End of User defined Installation!*

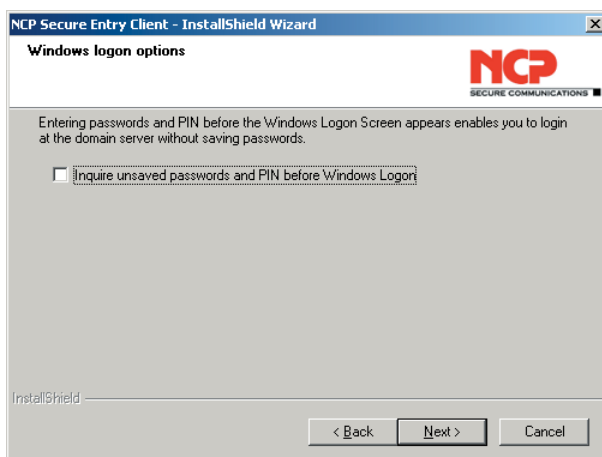

Thereafter you can define whether a logon to a remote domain should occur after establishing a connection to the remote destination’s NAS, which may necessitate entering the PIN for your certificate and/or your Password (if not already stored in the Client Software). After establishing a connection to the remote destination’s NAS, you can logon to the remote domain. This logon will be encrypted.



Please note: Activate this option before the Windows logon, thus the NCP Gina will also be automatically installed. The logon options can also be used only if the NCP Gina is installed after the Windows Gina - which is possible in this setup window. These logon options can be set via the Monitor menu of the Client under “Configuration”.



If the logon option is not activated here, and if it will be used at a later point in time, then the NCP Gina can be permanently installed after this setup using the command `rwscmd /ginainstall`. See the description “Secure Client Services” in this regard, in the appendix of this manual.

→ continue next page

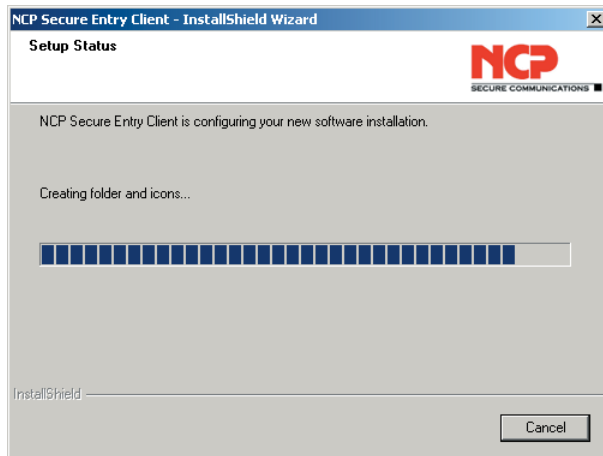

The data of the Client Software will now be copied.

The associated network components will now be installed.

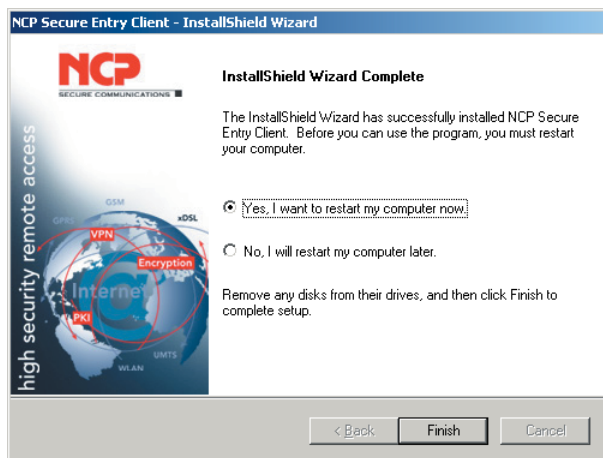

This completes the installation of the Client Software under Windows NT/2000/XP. Click the “Finish” button. Before using the Client Software it is necessary to reboot your PC. Click on “Yes, I want to restart my computer now” and then click on “Finish” to reboot your PC.



Refer to the section “Using the Client Software under Windows NT/2000/XP” to find notes for User Rights.

## 2.2.6 Using the Client Software under Windows NT/2000/XP

**In order to use the Client Software without having administration rights, read/write rights must be set for the following files and directories:**

1. All files of the installation directory (default: subdirektory NCPLE) require read rights (under Windows NT).
2. The NCPBM.DAT file requires read and write rights (Statistics, Budget Manager)
3. The file NCPPHONE.CFG requires read and write rights.
4. The file NCP.DB in the installation directory (default: subdirektory NCPLE) requires read and write rights.
5. Under Windows XP the installation directory (default: subdirektory NCPLE) requires full rights.



## 2.3 Initial Configuration Assistant

Once you have installed the Client Software and rebooted your PC, the Client Monitor will be automatically displayed on your PC. The “Initial Configuration Assistant” will also be displayed, provided that you have installed the Client Software for the first time on your PC and that no previous Phonebook exists from an earlier Client Software. It is located in the installation directory.

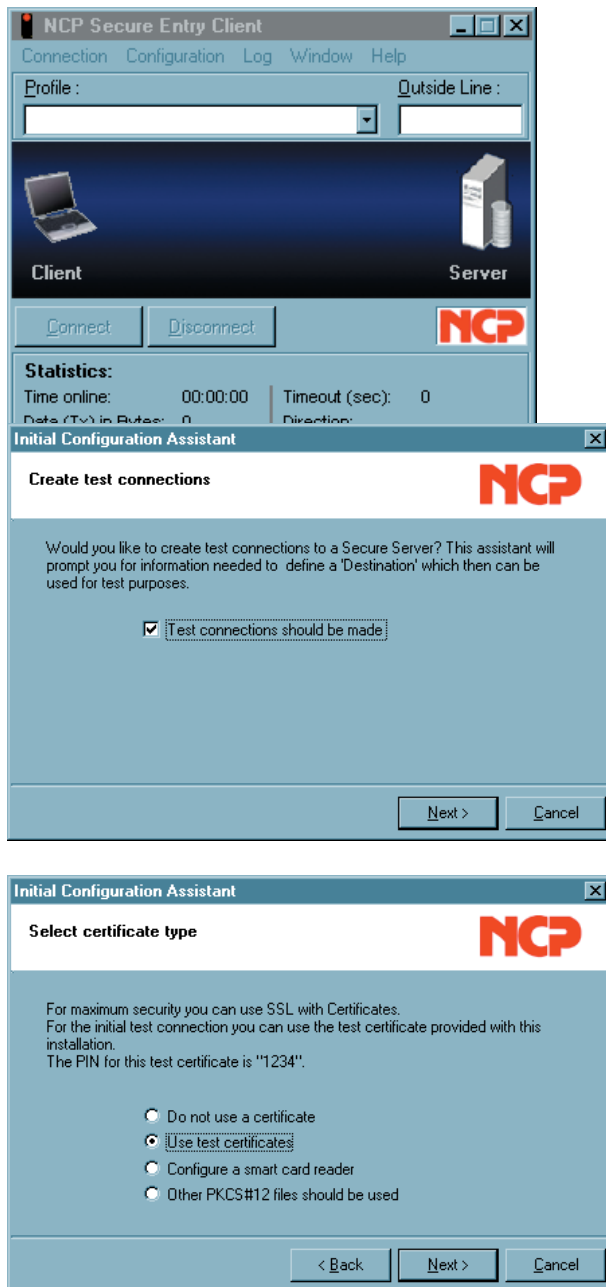

If you do not use the assistant for creating such test destinations, then no entries will be added to the phonebook. In this case you will have to create your own phonebook entries, as described in the chapter “Client Monitor” under “New Entry / Destination”.

If you use the assistant, click on “Next”. If selected then an IPSec test destination will be added to the client’s phonebook and the assistant will guide you through the definition of generic parameters. The following access data are created automatically: VPN protocol is IPSec, the Tunnel Endpoint of the VPN gateway is: 62.153.165.62, XAUTH userID and Password is “ncpipsecnative”. The link type is LAN. If a connection via an ISP should be established, the parameters for dial-up must be configured in the profil settings.

Setting up the variant with strong security you can use a test certificate.

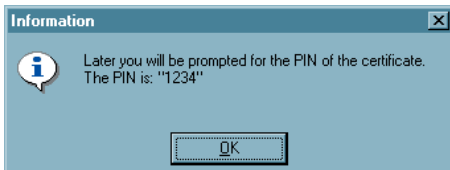

The PIN of the test certificate is "1234" and must be entered when establishing the connection.

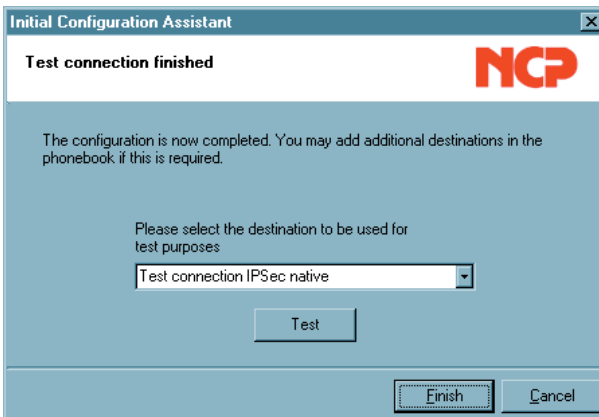

Once you have saved the test configuration, you can set up immediately a test connection (in LAN mode) by clicking the "Test" button.

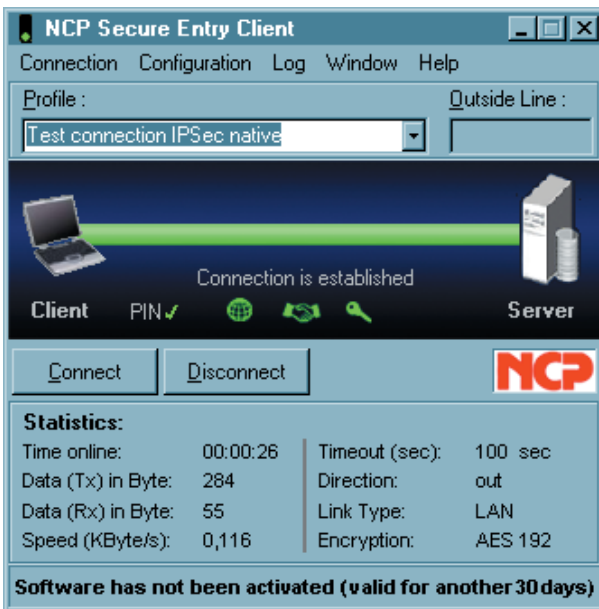

After the connection is established the monitor is displayed like shown on the left side.



For further configuration of any profile refer the descriptions under "Client Monitor, Profile Settings" and "Configuration Parameters, IPSec General Settings".

## 2.4 Updateing and Uninstalling



If you are already using a previous version of the Software it will be detected when attempting to install the new Client Software. If this is the case, then you will be asked if you wish to update your current Client Software to the newer version now in your possession. During the update the current profile settings, certificate data and call control manager statistics will be applied to the new client.

In order to uninstall the Client Software go to: “Start” →“Settings” →“Control Panel”. Now click on “Add/Remove Software” and then select the client from the list of programs and then click on the “Add/Remove” button. The Uninstall Shield Program will now delete the client software from your PC.



**Important:** After the removal of the software components, the profile and configuration settings are still saved and can be restored in the event a newer version of the client is installed. In order to completely delete everything; manually remove the installation directory (default \Windows\nclipse).

## 2.5 Upgrade to the Secure Enterprise Client

You upgrade from a Secure Entry Client to a Secure Enterprise Client by replacing the licensing and the software. This can be done manually on-site, or via an Update Server.

For a manual upgrade the software is reinstalled from the CD, and “NCP Secure Enterprise Client” is entered as the product to be installed. In this process the install program recognizes that a software version has previously been installed and executes an update after appropriate confirmation. Then the new activation key with serial number must be entered in the Pop-up menu.

For an upgrade via an Update Server - the IP address of the Update Server is entered in the client’s telephone book (see → DNS / WINS). In this case the Secure Client software will be downloaded automatically the next time the client dials into the corporate network. At the next dial-in with this new software a CNF file (profile settings) with licensing key will be downloaded. This concludes the update process.

*For your notes →*

### 3. Client Monitor

Once you have installed the Client the Monitor should appear automatically on PCs screen. To manually display the Monitor click on: Start / Programs / NCP Secure Client / Secure Entry Client Monitor. The Client Monitor will be loaded and displayed on the screen or in the task bar.



Note: When the monitor is loaded it will either be displayed on the screen (as well as the taskbar) or if it is not displayed but loaded it appears in the taskbar.

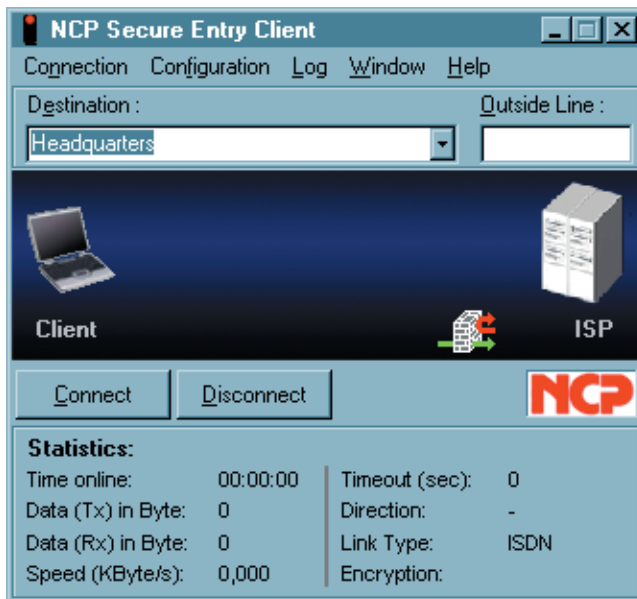

***The Client Monitor serves 4 important purposes:***

- to display the current communications status
- for selection of communication medium
- for definition of call control parameters
- for definition of profiles and associated destination and security parameters

## 3.1 The Client Monitor User Interface

### 3.1.1 Operating and Display Field

The Client Monitor consists of:

- A title header indicating the security version of the client,
- the main menu bar,
- A display of the selected Profile and a window for Outside Line Prefix,
- the graphic status field, displaying the communication status,



The field that displays signal strength only opens for connection types UMTS/GPRS/WLAN,



- the button bar with "connect" and "disconnect"
- and the statistics field

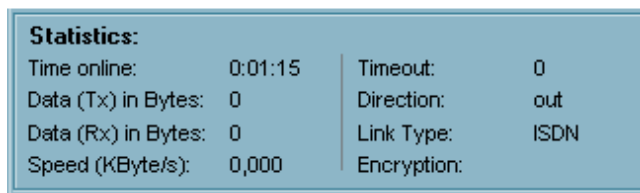

The user interface is conform Windows standards, and operation is similar to that of other Windows applications. The monitor can either be operated by using pull down menus from the menu bar, or by using buttons from the button bar, or via the context menu (right mouse button).

### 3.1.2 The Appearance of the Monitors

The monitor can be displayed in different sizes according to the setup in “Window” from the monitor menu (see → 3.2.5 Window).



The communication medium is shown in the statistic window or can be entered by defining the profile so that is displayed in the status field as well.

#### *Modification of the Interface*



The monitor appearance can be modified by the administrator. This is particularly relevant for the menu choices “Link Information”, “Certificates”, “Link Control” and “Logon Options”. Also the administrator can suppress profile parameter fields and can suppress individual parameters or set them to “non configurable”. The suppressed and deactivated features and parameters simplify software operation, they do not influence the performance of the software or your work. Refer the section 3.3 Configuration, 3.3.8 Configuration Locks.



### 3.1.3 Status Displays

The following status displays are shown in the graphic field next to the connection setup icons (see → Setting up a connection) and are extended by tool tips (quick info), when the cursor points to an icon.



#### ■ Smart Card

If a smart card has been installed (see Monitor menu → Configuration / Certificate) then the icon for a smart card will be displayed. It is displayed in light blue if the smart card has been configured, but not inserted, the icon is displayed in green if the smart card is inserted and has been detected.

#### ■ PIN Status

A check mark always indicates that the PIN number has been entered correctly. Incorrect PIN entries are indicated by error messages. The green PIN check mark indicates that the entered PIN is valid, even if a connection has not been setup. If you want to ensure that an unauthorized person cannot set-up a connection in your absence, then the PIN must be reset (see Monitor menu → Connection / Reset PIN), or the function “PIN query for each connection setup” must be activated under Configuration / Certificate”.

#### ■ Endpoint Policy

If endpoint security policies are used between Client and VPN Gateway, then the policy icon is displayed while the connection is being set-up. During verification of the policy, after the connection has been set-up, it is displayed with a yellow check mark, if the policies are satisfied it is displayed with a green check mark, if the policies are not satisfied, then the policy icon is displayed with a red check mark.

#### ■ Firewall Option

The firewall icon is always visible if a firewall is activated. If the global firewall (personal firewall) is active with defined rules and the link-specific firewall is not active, then the icon will be displayed without arrows. With an activated link firewall the icon is displayed with arrows, regardless of whether the global firewall is active or inactive.

If the Link Firewall in the phonebook is switched active with “Activate Stateful Inspection → always” and is configured so that communication is only permitted in the tunnel, then the firewall icon is displayed with two red arrows. If the option “Only allow communication in the tunnel” is switched off, then the icon will be displayed with a green arrow and a red arrow. If Stateful Inspection is only activated for an existing connection, then the icons only appear after a connection setup.

### ■ **Friendly Net Detection**

If a Friendly Net (e.g. corporate network) has been defined by the administrator, and the Secure Client accesses this Friendly Net, then the Firewall icon is displayed in green. Friendly Net Detection is configured in the Monitor configuration menu under “Firewall settings / Friendly Nets”, either by specifying static network routes, or by activating the automatic detection of Friendly Nets. See the description under “Firewall settings / Configuration field – Friendly Nets” for more information.

### ■ **EAP Status**

An extended authentication with MD5 or TLS prior to tunnel setup is indicated with “EAP”. The color yellow indicates the EAP negotiation phase, green indicates successful authentication with EAP, red indicates failed authentication.

Double click on the EAP icon to reset the EAP. Subsequently a new EAP negotiation will be executed automatically. If there is successful authentication relative to a network component, the other side will respond back specifying which protocol (MD5 or TLS) was used.

Extended authentication can be configured in the phonebook (for LAN or WLAN connections) under “Authentication before VPN”. If EAP authentication is selected, then in the monitor menu under “Configuration / EAP options” the Extended Authentication Protocol for LAN must be activated, and user ID and password must be entered. The EAP icon is displayed only after these steps have been executed.

### 3.1.4 Dialing-up und selecting the Profile

Once the software has been installed and a profile has been configured correctly (see → 3.2.3 Configuration), you are ready for dialing up to the selected destination.

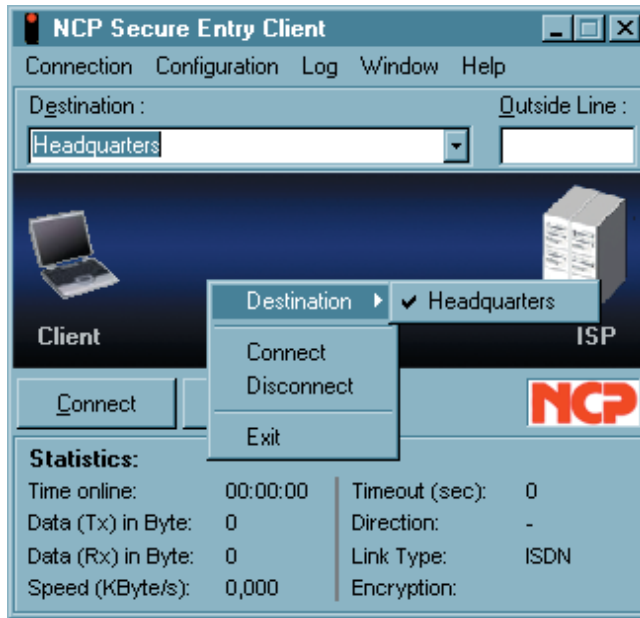

The profile can be selected in two ways: either from the pull-down menu, or from the pop-up menu invoked by clicking on the right mouse button. (see illustration)

In order to establish a connection it is therefore not necessary to start the client monitor itself or to dial-up manually. The only software that must be started is the desired application software (Email, Internet browser, terminal emulation, etc.). The connection will then be established automatically (see →Line Management, Connection Mode, automatically).

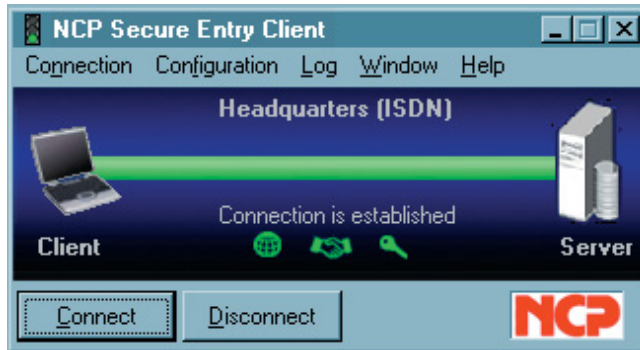

It is also possible to manually establish the connection to a selected destination by selecting "Connection" in the main menu and click on "connect". Alternatively you can click on the "connect" button in the tool bar.



When the connection is established (see →illustration above), the monitor displays a thick green bar from the Client to the Server under which the text "Connection is established" is displayed. At the same time, the traffic lights change from red to green. The green traffic light denotes an established connection and occurring costs.

## 4. Using the Client Monitor

The description follows the menu items in the menu bar.

The menu-bar consists of the following items from left to right:

- Connection
- Configuration
- Log
- Window
- Help

## 4.1 Connection

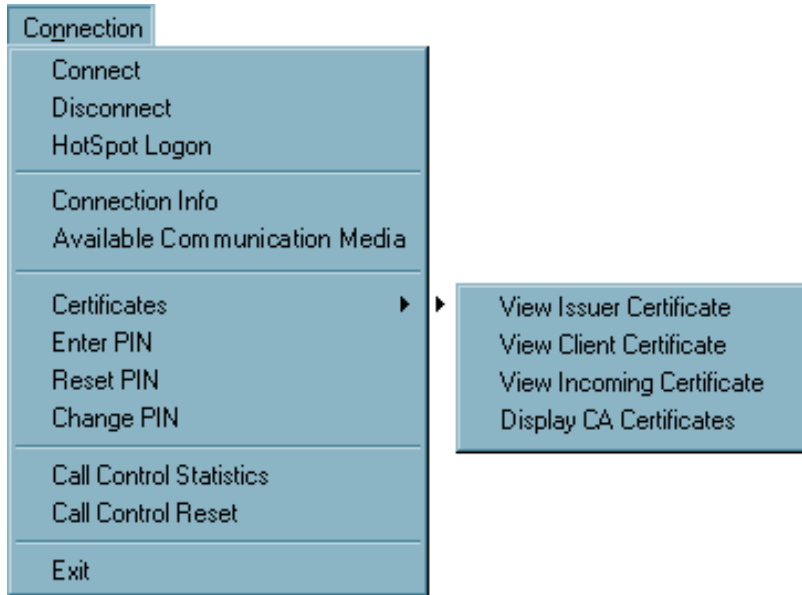

*With this choice you will find commands for Link establishment and Link break-off. You will also find information windows displaying the current link establishment and the implemented certificates. In addition Link control statistics can be read here and if required the Link control barrier can be deleted if a threshold value that you have set is exceeded.*

### 4.1.1 Connect

This command is used to initiate a connection. A connection can only be made if a profile has been properly defined and selected in the Profile Settings (see →Profile Settings, Basic Settings). The selected profile is displayed in the “Profile” field of the monitor.

Selecting the function “Connect” the connection will be established manually to the destination system. Whether the link is built manually or automatically depends on the “Connection Mode” defined for the profile in the Line Management folder of the profile settings as well as the communication medium being used (see →Profile Settings, Line Management, Connection Mode).

### 4.1.2 Disconnect

A connection can be terminated manually by clicking on “Disconnect” in the Connection pull-down menu or by clicking the right mouse button. As soon as the connection has been terminated, the “traffic light” switches from green to red.

### 4.1.3 HotSpot Logon



Requirements: The user must be in the receiving range of a hotspot, with an activated WLAN card. There must be a connection to the hotspot and the wireless adapter must have an assigned IP-address. (Windows XP provides you with the needed configurations concerning access to WLANs).

The clients firewall makes sure that only the IP-address assignment is being done by DHCP without any further possibilities of access to or from the WLAN. The firewall has intelligent automated processes for clearing the ports of one or more https so as to make logins and -outs to the hotspot available. During this process only data traffic to the hotspot server is possible. In this way a public WLAN can only be used for connecting VPN to the central data network, direct internet access is excluded. For opening the homepage of a hotspot in the browser a possible existing proxy-configuration must be deactivated.



At present the clients hotspot access works only with those hotspots, that redirect inquiries with the help of browsers to the homepage of the public WLAN provider (for example T-Mobile or Eurospot).

Under previously described conditions a click on the menu option “HotSpot Logon” opens the website to log into the standard browser. After entering the access data the VPN-connection to, for example, the company’s headquarters can be established and safe communication is possible. If hotspot logon has not been executed by the client the user gets the message “HotSpot could not be found”. In this case it must be checked whether a general problem exists in conjunction with the implemented mechanisms relative to the hotspot operator.

## 4.1.4 Connection Info

Upon selecting the menu parameter “Connection Info” link statistics are displayed. The window also displays the type of security features being used as well as the IP addresses that have been assigned between the IPSec client and the destination resulting from the PPP negotiation. The information in the connection info window is “read-only” and has no influence on the functionality of the IPSec client.



The field “Connection Info” could be suppressed by the administrator. In this case the menu item could not be activated.

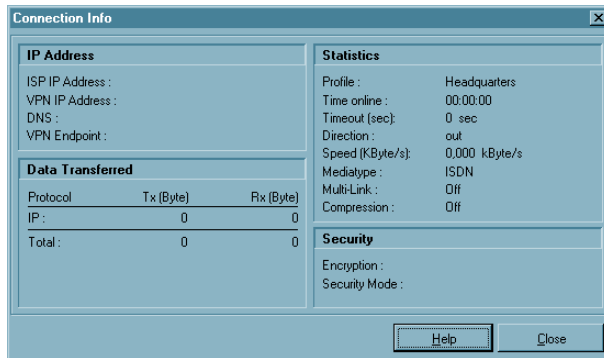

If the connection info is faded, the most important information concerning data transfer, statistic and security can be seen in the statistic field of the monitor (see → Window, Show Statistics).

### ■ Time Online

Time Online indicates the total amount of time that the PC is actually connected to the destination, regardless of any timeouts (disconnects). The value is reset to zero (0) either as a result of (re)booting your PC or when you change the destination.

### ■ Timeout

The Client Monitor displays the time remaining until the next timeout (disconnect) occurs, which begins immediately following the last exchange of data over the Link (including any handshaking). (See → Phonebook, Line Management).

### ■ Direction

Direction indicates the current direction of communications as follows:

Out = outbound or outgoing call is currently being executed.  
 In = inbound or incoming call is currently taking place.

### ■ Speed

The displayed number varies according to the current data throughput.

### ■ Multilink

If a connection is established via several ISDN-B channels, the statistic shows “on”.

## ■ Media Type

The following Media Types are supported: ISDN, Modem, LAN over IP, xDSL (PPPoE), xDSL (AVM – PPP over Capi), GPRS and PPTP.

## ■ Compression

Compression is always defined by the gateway. IPsec compression is displayed with “IPsec Compression (LZS)”.

## ■ Encryption

The used encryption type is displayed. Following types of encryption are supported: AES, Blowfish, 3DES. The encryption type is assigned by the central site (gateway).

## ■ Key exchange

Display what Session Key exchange method is used:

- |             |   |  |
|-------------|---|--|
| Static Key  | = | The same Static Key must be used at both endpoints of communication. It is entered under “Profile Settings → Identity” |
| IKE (IPsec) | = | To transfer the Session Key, the encrypted Control Channel of Phase 1 negotiation is used.                             |

## ■ Rx and Tx Bytes

Rx and Tx Bytes indicates the amount of data being sent (out) and received (in) for each protocol and for each communications session. The amount of data is expressed in Bytes (1 byte = 1 character). The total amount of data sent and received for all protocols is also displayed.

## 4.1.5 Available Communication Media



The purpose of this window is only to inform about the available communication media and the currently used communication medium. On the basis of a pre-configured destination system, those link types that are currently available for the Client PC are detected and implemented, and if multiple alternative transmission paths are available, the fastest will be selected automatically.

The available communication media are displayed with yellow signal lamps and the automatically selected with a green signal lamp.

For configuration purposes note the description of “Automatic Media Detection” in the parameterfolder “Destination System” of the phonebook.



## 4.1.6 Certificates

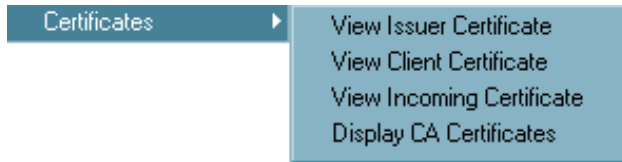

In the pulldown menu “Connection” you will find the entry “Certificates” which consists of the following submenus “Configuration”, “View Issuer Certificate”, “View Client Certificate”, “View Incoming Certificate” and “Display CA Certificate”.

Certificates are normally created by a CA (Certification Authority) utilizing some sort of PKI-based architecture and they may be implemented on a Smart Card in addition to a digital signature(s). Such Smart Cards represent an individual “personal identity card”.

### ■ View Issuer Certificate

In order to view the Issuer Certificate select “Connection → Certificate → View Issuer Certificate”. Upon doing so the individual assigned data will be displayed (read-only) for your review purposes.

Certificate Authority = The CA and the issuer of a Issuer Certificate are normally identical (self-signed certificate). The CA of the Issuer Certificate has to be identical with the CA of the Client Certificate (see → View Client Certificate).

Serial Number = The serial number of the certificate can be compared with the registered serial number in the Revocation List of the Certification Authority.

Validity = The validity of certificates is limited. Normally the validity of a Issuer Certificate is longer than the validity of a Client Certificate. Upon expiration of the Issuer Certificate, the validity of the Client Certificate of the same CA expires as well.

Fingerprint = Hash value. The Hash value is the signature of the certificate. The Hash value is encrypted with the private key of the CA.

## ■ View Client Certificate

In order to view the Client Certificate select “Connection → Certificate → View Client Certificate”. Upon doing so the individual assigned data will be displayed (read-only) for your review purposes.

Certification Authority (CA)	=	The CA and the issuer of a Client Certificate is normally identical (self-signed certificate). The CA of the Client Certificate has to be identical with the CA of the Issuer Certificate (see → Issuer Client Certificate).
Serial Number	=	The serial number of the certificates can be compared with the registered numbers in the Revocation List of the Certification Authority. (see → strong Radius Authentication)
Validity	=	The validity of certificates is limited. Normally the validity of a Issuer Certificate is longer than the validity of a Client Certificate. The expiration of validity erases the functionality of certificates.
Fingerprint	=	Hash value. The Hash value is the signature of the certificate. The Hash value is encrypted with the private key of the CA.

## ■ View incoming Certificate

Display of the certificate that is communicated in the SSL negotiation from the other side (Secure Server). You can see, for example, whether you have accepted the issuer displayed here in the list of your CA certificates (see below).

If the incoming user certificate is one of the CAs not known from the list “Display CA Certificates”, then the connection will not take place.

If no certificates are stored in the Windows directory `NCPLE\CACERTS\`, then no verification takes place.

## ■ Display CA Certificates

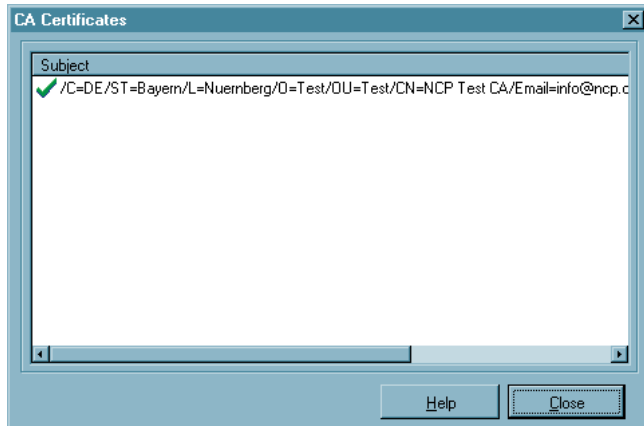

Multiple issuer certificates are supported with the client software (multiple CA support). The issuer certificates must be collected in the Windows directory `NCPLE\CACERTS\` for this. In the client monitor the list of CA certificates read in is displayed under the menu item “Connection →Certificates →Display CA Certificates”,

If the issuer certificate of another side is received, then the client determines the issuer, then searches for the issuer certificate, first on Smart Card or in the PKCS#12 file, and then in the `NCPLE\CACERTS\` directory.

If the issuer certificate is not known, then the connection will not be established (No Root Certificate found). If no CA certificates are present in the Windows directory `NCPLE\CACERTS\`, then a connection that implements certificates is not permitted.

## ■ Display and analysis of extensions for incoming certificates and CA certificates

Certificates can contain extensions. These serve for the linking of additional attributes with users or public keys, that are required for the administration and operation of the certification hierarchy and the revocation lists. In principle, certificates can contain any number of extensions, including those that are privately defined. The certificate extensions are written in the certificate by the issuing certification authority.

Three extensions are significant for the IPSec client and the gateway:

- extendedKeyUsage
- subjectKeyIdentifier
- authorityKeyIdentifier

## Display of extensions

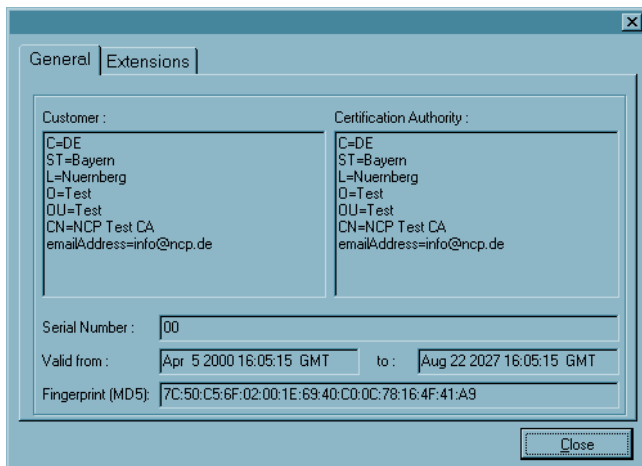

To display the extensions of an incoming or CA certificate you have to proceed as follows:

The Ca certificate which extension should be displayed, has to be opened by a double click in the window of Ca certificates. Upon doing so the next window with general information is opened.

For the incoming certificate this window is already opened after “View incoming certificate” was selected in the certificate menu.

The window “General” displays the general certificate data

The window “Extensions” displays the certificate extensions if available.

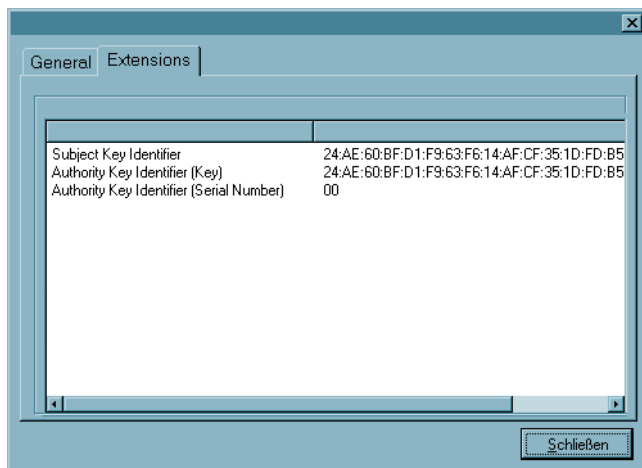

## Extension checks

### KeyUsage

If the KeyUsage extension is contained in an incoming certificate, then it will be verified. The following KeyUsage bits are accepted:

- Digital Signature
- Key Encipherment (key transport, key management)
- Key Agreement (key exchange process)

If one of the bits is not set, then the connection is interrupted.

### extendedKeyUsage

If the extendedKeyUsage extension is present in an incoming user certificate, then the Secure Client checks whether the defined extended application intent is “SSL Server Authentication”. If the incoming certificate is not intended for server authentication the connection will be refused. If this extension is not present in the certificate, it will be ignored.



Please note that the SSL server authentication is direction-dependent. This means that the initiator of the tunnel establishment checks the incoming certificate of the other side, which, if the extendedKeyUsage extension is present, must contain the intended purpose “SSL Server Authentication”. This applies also for a callback to the Client via VPN.

Exception: For a server call-back to the client after a direct dial-up, without VPN but with PKI, the server checks the client certificate for the extendedKeyUsage extension. If this is present, then the intended purpose “SSL Server Authentication” must be contained otherwise the connection will be rejected. If this extension is not present in the certificate it will be ignored.

### subjectKeyIdentifier / authorityKeyIdentifier

A key identifier is an additional ID (hash value) to the CA name on a certificate. The authoritykeyidentifier (SHA1 hash over the issuer’s public key) on the incoming certificate must agree with the subjectKeyIdentifier (SHA1 hash over the public key of the owner) on the corresponding CA certificate. If no CA certificate is found then the connection is rejected.

### CDP (Certificate Distribution Point)

The URL for downloading a CRL is stored in the CDP. If the CPD extension is contained in the certificate, then after the connection is setup, the CRL is downloaded via the specified URL and checked. If the system determines that the certificate is invalid the connection is disconnected. During this process the CRL is stored in the `nple\crls` directory, under the common name of the CA.

### 4.1.7 Enter PIN

The PIN entry can be executed before establishing a connection, after the monitor has been started. If a connection requiring a certificate is established at a later time, then the PIN entry can be omitted – unless the configuration for the certificate requests it (see →Configuration, Certificates).

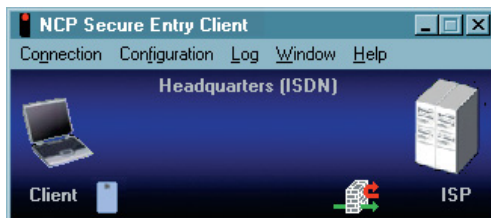

If you have configured the IPsec client for the use of a Smart Card or of a PKCS#11 module (see →Configuration, Certificates), then a light blue symbol for the Smart Card appears in the status field. If you have inserted your Smart Card in the card reader, the symbol color changes from light blue to green.

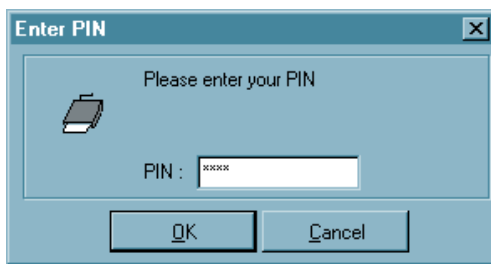

If the PIN has not been entered before a connection establishment, then the PIN entry dialog appears when the first connection requiring the use of a certificate is to be established to a destination at the latest. Thereafter the PIN entry can be committed in the case of repeated manual connection establishment, if this has been configured (see →Configuration, Certificates).



Using a soft certificate the PIN can have of 4 digits. Using a Smart Card it must have at least 6 digits.



Incorrect entries and incorrect PINs are acknowledged with the error message “Incorrect PIN!” after approximately 3 seconds. At this point a connection establishment is not possible. Please note that a Smart Card or a token can be blocked after multiple incorrect PIN entries. In this case, please contact your remote administrator. An established connection will, by default, be disconnected if the Smart Card or token is removed during the operation.



The connection establishment can only be executed after correct PIN entry.

## *Safeguarding PIN Use*

If you activate the function, “PIN request at each connection”, in the certificate configuration, then the PIN can no longer be entered via the “Enter PIN” Monitor menu option. The menu option “Enter PIN” is thus switched to inactive automatically. This ensures that the PIN will only be queried and can only be entered directly before the connection is set-up.

Activate this function to prevent an unauthorized user from setting up an undesired connection if the PIN has already been entered.

Likewise, if the “Change PIN” function has been switched active, then the PIN that has already been requested in other function contexts is no longer used – i.e. when setting up a connection, or in the “Enter PIN” connection menu. Instead you can always select the menu option “Change PIN” and the new PIN will be automatically reset immediately after the change.



This ensures that when configuring “PIN query at every connection set-up” on an unauthorized Client Monitor, a PIN entered previously by an unauthorized user cannot be used at anytime to set-up a connection.

### 4.1.8 Reset PIN

This menu item can be selected for deleting the PIN, for making the valid PIN useless to other users. It can be helpful for example if you leave your client temporary or if the user changes. Afterwards a valid PIN must be reentered again for authentication.

#### ■ **PIN State Symbol Visible in the Client Monitor.**

If a valid PIN is entered this is symbolized by a green check next to the PIN display in the client monitor. If the PIN has not yet been entered correctly the green check will not appear.

#### ■ **PIN Handling after Logoff or Sleep Mode**

When a user logs off Windows NT/2000/XP the PIN cache is cleared and must be reentered at next logon. When the machine enters sleep mode the PIN cache is also cleared.

#### ■ **Displaying ACE Server Messages for RSA-Token**

If messages are sent by the ACE server because of the RSA token they will be displayed on the monitor in an input field (for example “Expiration of valid PIN”).

## 4.1.9 Change PIN

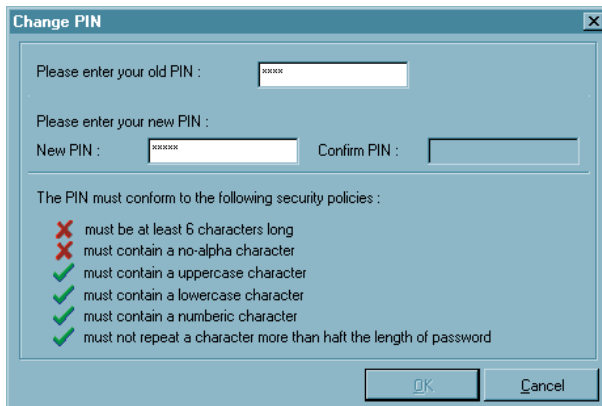

Change PIN

Please enter your old PIN :

Please enter your new PIN :  Confirm PIN :

The PIN must conform to the following security policies :

- must be at least 6 characters long
- must contain a no-alpha character
- must contain an uppercase character
- must contain a lowercase character
- must contain a numeric character
- must not repeat a character more than half the length of password

OK Cancel

The PIN for a Smart Card or for a soft certificate can be changed under the menu item “Change PIN”, if the correct PIN number has previously been entered. This menu item will not be activated without the previous entry of a valid PIN number.

For security reasons, after opening this dialog the still valid PIN must be entered a second time. This is to insure PIN change for the authorized user only. The digits of the PIN are displayed in this entry field, and in the next entry fields as asterisks “\*”.



Then enter your new PIN and confirm it by repeating it in the last entry field. With a click on “OK” you have changed your PIN. PIN policies that need to be complied with are displayed under the entry field. They can be set in the main menu under “Certificate →PIN Policies”.

By entering a new PIN the red X will change to a green check as soon as the guidelines are fulfilled. (see illustration above)



### 4.1.10 Call Control Statistics

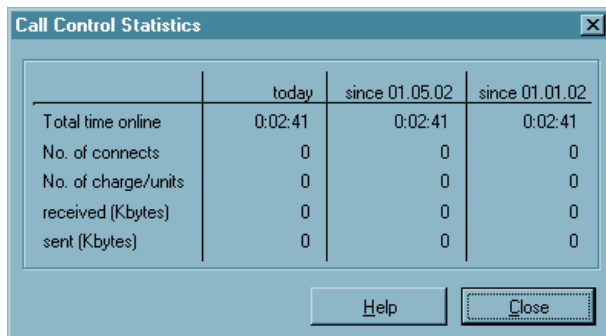

The image shows a dialog box titled "Call Control Statistics" with a close button (X) in the top right corner. It contains a table with the following data:

	today	since 01.05.02	since 01.01.02
Total time online	0:02:41	0:02:41	0:02:41
No. of connects	0	0	0
No. of charge/units received (Kbytes)	0	0	0
sent (Kbytes)	0	0	0

At the bottom of the dialog box, there are two buttons: "Help" and "Close".

Call Control Statistics provide you with an overview of your communications on a daily, monthly and yearly basis. It accurately displays the following information:

- total time online
- total number of connects (outgoing calls)
- total number of charge/units (if available)
- total amount of data (expressed in Bytes) sent and received

### 4.1.11 Call Control Reset



If the "Limits" defined in the Call Control Manager have been exceeded, the IPsec client issues a "Warning Message" and blocks any further communications until such time that the "Call Control Reset" has been activated (see → "Connection" pull-down menu in the Monitor).

A connection can only be established after clicking "Call Control Reset".

### 4.1.12 Exit (Disconnect the Monitor)

Have you already disconnected the link, a click on this menu item or on the “Disconnect” button closes the monitor.



If the connection is still established, with a click on this menu item or on the “Disconnect” button the monitor can be closed as well. Please note that closing the Monitor does not automatically terminate the connection. If the link should be established although the monitor is closed and fees may occur, the software asks you explicitly for a prompt.

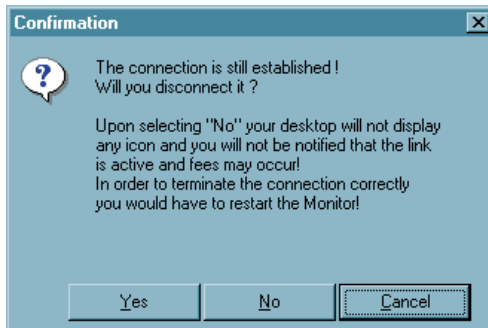

Upon selecting “No” your desktop will not display any icon and you will not be notified that the link is active and fees may occur! In order to terminate the connection correctly you would have to restart the Monitor!

## 4.2 Configuration

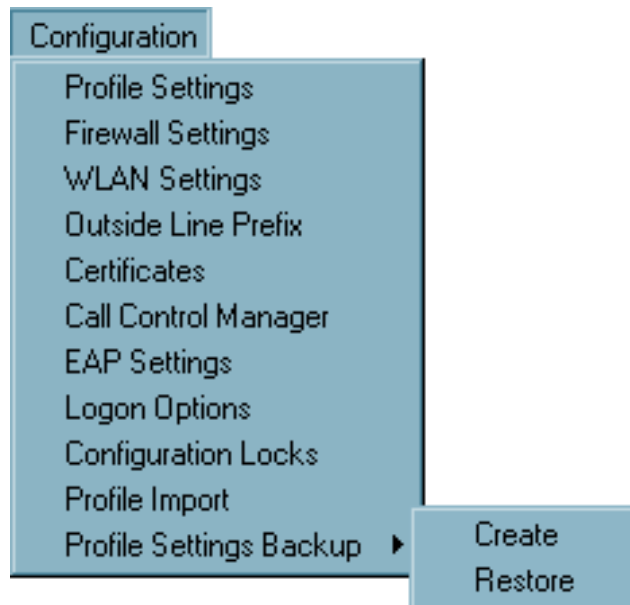

*You can specify all settings for work with the IPSec Client, which should work longer than one session, with this menu choice. Specifically this means creating profiles, configuration for IPSec links, choosing communication media, as well as obtaining an outside line for connections to telecommunications systems.*

*In addition you can individually configure precisely how certificates should be used, how the call control manager should work and which configuration rights the user receives.*

## 4.2.1 Profile Settings

### ■ Entries in the profile settings

After installing the Secure Client for the first time it will be necessary to define a profile for your requirements in the profile settings. For this purpose there is a “Configuration Assistant”, which will walk you through the configuration steps of a profile. In this way the first profile will be created.

The profile settings provide the basis for defining and configuring destinations (profiles) which can be modified or reconfigured at any time according to requirements.

Upon clicking “Profile Settings” in the Monitor menu “Configuration” the menu is opened and displays an overview of the defined profiles and their respective names and the telephone numbers of the according destinations.

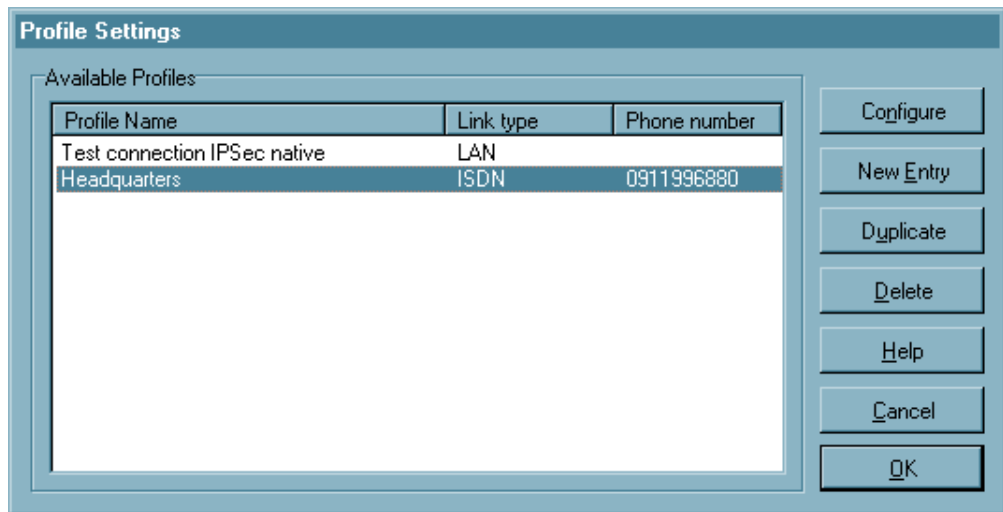

*There is also a toolbar with the following function buttons: Configure, New Entry, Duplicate, Delete, OK, Help and Cancel.*

### ■ New Entry – Profile

In order to define a new Destination, click on “Profile Settings”. When the window opens click on “New Entry”. Upon doing so the “Configuration Assistant” opens and walks you through the configuration of a new Profile according to your requirements. Upon entering all items in the assistant the new profile is entered in the Profile Settings based on these parameters. All other parameters are assigned a default value.

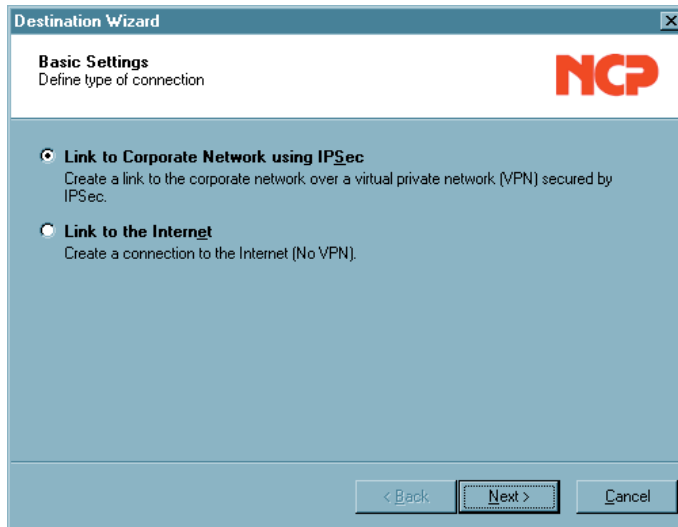

*Using the configuration assistant, connections can be quickly established with the Internet or to the corporate network. The profile is created after a few configuration questions, in accordance with the selection of the desired basic setting.*

Below are the required data for the configuration:

#### **Link to Corporate Network using IPsec:**

- Profile Name
- Communication Medium
- Access data for Internet Service Provider (User ID, Password, Phone Number)
- VPN-Gateway selection (Tunnel Endpoint IP address)
- Access data for VPN Gateway (XAUTH, User ID, Password)
- IPsec Configuration (Exch. Mode, PFS Group, Compression)
- Static key (Preshared Key), without certificate (IKE ID Type, IKE ID)
- IP Address Assignment (IP address of the client, DNS/WINS Server)
- Firewall Settings

#### **Link to the Internet:**

- Profile Name
- Communication Medium
- Access data for Internet Service Providers (User ID, Password, Phone Number)

The new profile is displayed now in a list of profiles with its assigned name. If no further parameter settings are necessary you can close the profile settings by clicking on “Ok”. The new profile is immediately available in the monitor. It can be selected in the monitor and via the menu “Connection →Connect” a connection to the relating destination can be established.

## ■ Configure – Profile

If you want to change any default profile data and parameters, start by selecting the appropriate profile and then click on the “Configure” button. Upon doing so a folder opens and displays a list of the following parameter folders on the left side:

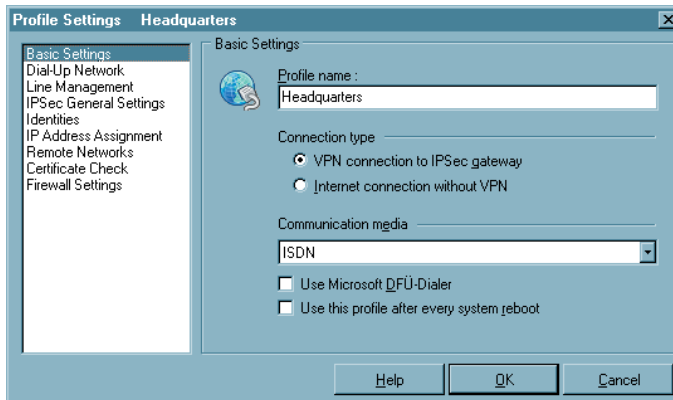

*Basic Settings*  
*Dial-Up Network*  
*Modem*  
*Line Management*  
*IPSec General Settings*  
*Identity*  
*IP Address Assignment*  
*Remote Networks*  
*Certificate Check*  
*Firewall Settings*

Upon selecting one of the folders the associated parameters will be displayed (see →4. Configuration Parameters).

## ■ Ok – Profile

Upon clicking “OK” in the configuration window the configuration of a profile is concluded. The new or modified profile is available in the monitor. It can be selected in the monitor and via the menu “Connection →Connect” a connection to the relating destination can be established.

## ■ Duplicate – Profil

You may want to use an existing profile for the basis of a new profile, perhaps however with slight modifications. In order to do so first select the profile to be duplicated and then click on the “Duplicate” button. Upon doing so the “Basic Settings” parameter folder will open. You must now enter a new name for the profile and then click on “OK”. A new profile is now created with parameters identical to the profile that was duplicated except for the Profile Name.



Important: It is not possible to have 2 or more profiles with identical names. Each profile must be assigned its own unique name.

## ■ Delete – Profile

If you want to delete a profile select the appropriate profile and then click on the “Delete” button.

## 4.2.2 Firewall Settings

All firewall mechanisms are optimized for Remote Access applications and are activated when the computer is started. This means that in contrast to VPN solutions with autonomous firewall, the teleworkstation is already protected against attacks before actual VPN utilization.

The Personal Firewall also offers complete protection of the end device, even if the client software is deactivated.

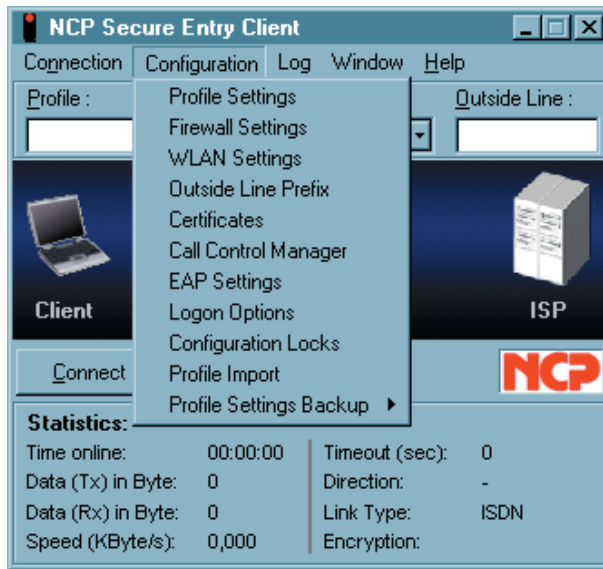

**Please note that the firewall settings are globally valid, i.e. they apply for all destination systems in the telephone book.**



On the other hand the Link Firewall Setting that is made in the telephone book can only be effective for the associated telephone book entry (destination system) and the connection to this destination system.

## ***Firewall properties***

The firewall works in accordance with the principle of packet filtering, in conjunction with Stateful Packet Inspection (SPI). The firewall checks all incoming and outgoing data packets and decides whether a packet will be forwarded or rejected on the basis of the configured rules.

Security is ensured in two ways. First unauthorized access to data and resources in the central data network is prevented. Secondly the respective status of existing connections is monitored via Stateful Inspection. Moreover the firewall can detect whether a connection has opened “Spawned connections” – as is the case with FTP or Netmeeting for example – whose packets likewise must be forwarded. If a rule is defined for an outgoing connection, which permits an access, then the rule automatically applies for the corresponding return packets. For the communication partner a Stateful Inspection connection is represented as a direct line, which can only be used for an exchange of data that corresponds to the agreed rules.

The firewall rules can be configured dynamically, i.e. it is not necessary to stop the software or restart the system.

The firewall settings in the configuration menu of the Client Monitor permit a more precise specification of firewall filtering rules. They have a global effect. This means that regardless of the currently selected destination system, the rules of the extended firewall settings are always worked through first, before the firewall rules from the telephone book are applied.

A combination of the global and link based firewall can be quite effective in certain scenarios. However generally, the global setting possibilities should be able to cover virtually all requirements.

Please note that the link-based firewall settings take priority over the global firewall settings at activation. For instance if the Link Firewall is set to “Always” and “Only allow communication in the tunnel”, then in spite of global configuration rules that may possibly be different, only one tunnel can be set-up for communication. All other traffic will be rejected by the Link Firewall.

## ***Configuration of the firewall settings***

The filter rules of the firewall can be defined application-based as well as (additionally) address-oriented, relative to friendly/unknown networks.

To avoid any conflict between the rules of the Link Firewall in the phonebook and the global firewall, we recommend to switch off the Link Firewall when using the advanced global firewall. The IP addresses of the respective links (to the VPN gateway) can be inserted in the filter rules of the global firewall.



## ■ Configurationfield Basic Settings

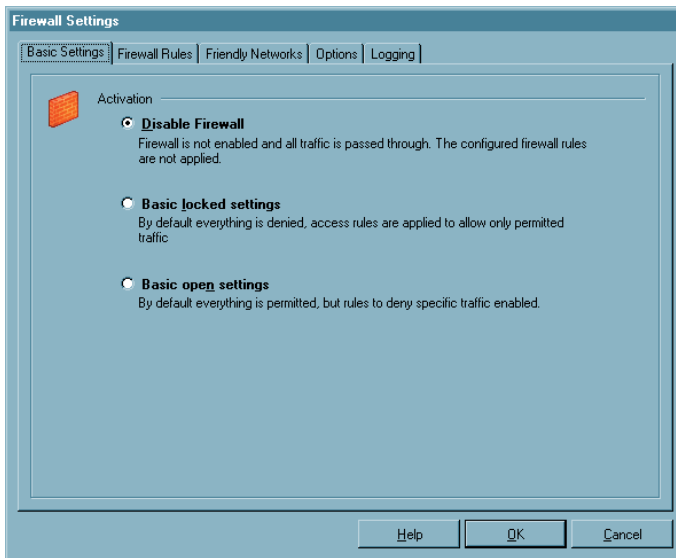

*In the basic settings you decide how the extended firewall settings will be used.*

### ***Disable Firewall***

If the extended firewall is deactivated, then only the firewall configured in the telephone book will be used. This means that all data packets will only be worked through via the security mechanisms of this connection-oriented firewall, if they have been configured.

### ***Basic locked settings (recommended)***

If this setting is selected, then the security mechanisms of the firewall are always active. This means that without additionally configured rules all IP data traffic will be suppressed.

The exception are the data packets that are permitted (permitted through) by the separately created active firewall rules (Permit Filter). If a characteristic of a data packet meets the definition of a firewall rule, then at this point the work through of the filter rules is ended and the IP packet is forwarded.

In the blocked basic setting mode in a convenient manner an L2Sec/IPSec tunnel connection is released.

For this, the data traffic can be globally permitted in the configuration field "Options", via VPN protocols (L2Sec, IPSec).

### ***Basic open settings***

In the open base setting all IP packets are first permitted. Without additional filter rules all IP packets are forwarded.

The exception are the data packets that are filtered out (not permitted through) by the separately created active firewall rules (Deny Filter). If one of the characteristics of an IP packet coming into the server/client meets the definition of a Deny Filter, then at this point the working through of filtering rules ends, and the IP packet will not be forwarded. Data packets that do not meet a suitable Deny Filter are forwarded.

## ■ Configurationfield Firewall Rules

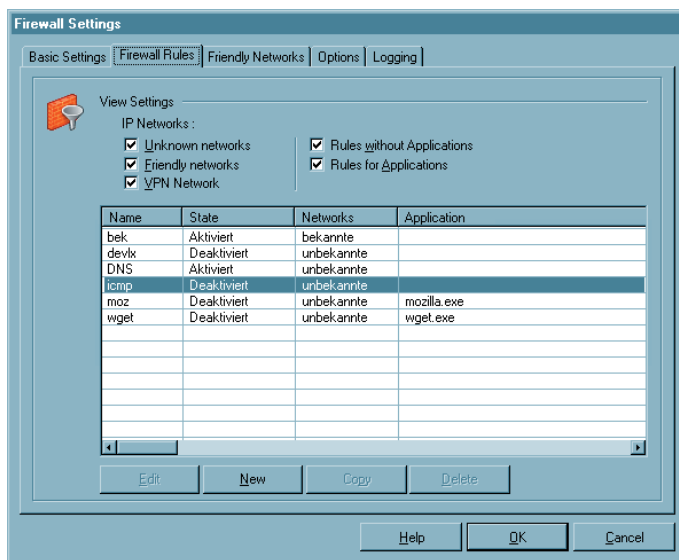

The rules for the extended firewall are brought together in this configuration field. The display options are all active by default and correspond to the selected networks, for which the respective rule can be defined, and whether this rule will be valid regardless of application:

- Unknown networks
- Friendly networks
- VPN networks
- Rules with applications
- without applications

These selection fields for the displays of rules are only for overview purposes and have no effect on the application of a filter rule. The most important characteristics are displayed for each defined rule:

- Name
- State
- Networks
- Application

Clicking on these characteristic buttons sorts the displayed rules.

### Creating a firewall rule

Use the buttons underneath the display line to generate or edit the rules. To create a firewall rule click on “New”. A filter rule is created via four configuration areas or tabs:

- General: In this configuration field you specify the network and the protocol for which the rule will apply.
- Local: Enter the values of the local ports and IP addresses in this configuration field.
- Remote: Enter the port and address values of the other side in the remote field.
- Applications: In this configuration field the rule can be assigned to one or more applications.

## ■ Firewall rule / General

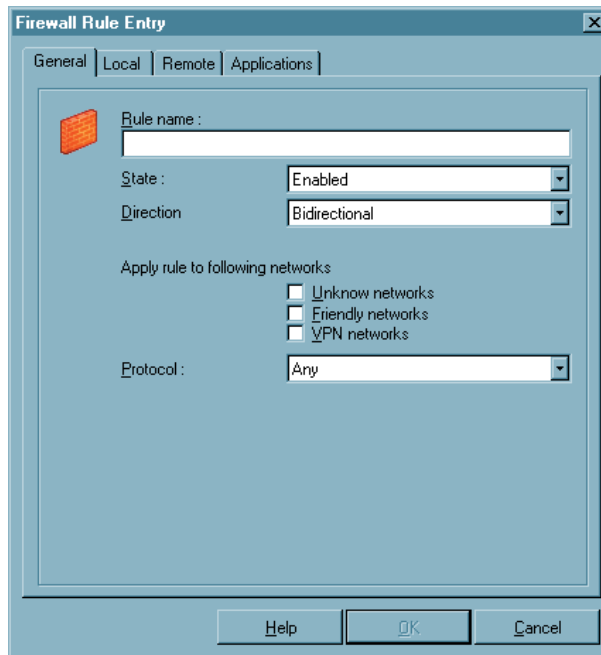

The created rule is always executed as an exception to the basic setting (see → Basic Settings).

### Rule name

The rule appears under this name in the display list.

### State

The rule will only be applied to data packets, if the status is “active”.

### Direction

With the direction you specify whether this rule will apply for incoming or outgoing data packets. According to the Stateful Inspection principle, data packets are received that come in from a destination, to which data packets may be sent and vice versa. However Stateful Inspection is only used for TCP/IP protocols (UDP, TCP).

You can switch to “incoming” for instance if a connection will be set-up from the remote side (e.g. for “incoming calls” or administrator accesses).

The “bi-directional” setting is only practical if Stateful Inspection is not available, e.g. for the ICMP protocol (for a ping).

### Apply rule to following networks

When creating a rule, at first do not assign it to any network. A rule can only be saved if the desired allocation has been made and if a name has been assigned.

#### *Unknown networks*

– are all networks (IP network interfaces), that can neither be allocated to a known nor VPN. These include for example connections via the Microsoft remote data transmission network or also direct or unencrypted connections with the integrated dialer of the client, as well as Hotspot WLAN connections. If a rule will apply for unknown networks then this option must be activated.

*Known networks*

– are defined in the tab of the same name in the “Firewall settings” window. If a rule will apply for known networks then this option must be activated.

*VPN networks*

– are all L2Sec or IPSec connections in the set-up condition. Moreover under this group there are also all encrypted direct dial-in connections via the client’s integrated dialer. If a rule will apply for VPN networks then this option must be activated.

**Protocol**

Select the appropriate protocol depending on the application:

TCP, UDP, ICMP, GRE, ESP, AH, IGRP, RSVP, IPv6 or IPv4, all

**Line management**

Use this parameter to influence the type of connection.

For example, you select the option that the rule configured here “is only valid at inactive VPN connection”, if you an Internet connection with concurrently present VPN connection to be excluded, otherwise the Internet connections to unknown networks should be allowed. For this, this rule for “unknown networks” must be used, i.e. this rule must permit access to unknown networks.

The option, “no automatic connect” is only practical if in the telephone book the connection set-up has been set to “automatic” in the “Line Management” parameter field. For the data packets defined via this rule, automatic connection set-up does not take place when activating this function, it does for other data packets.

## ■ Firewall rule / Local

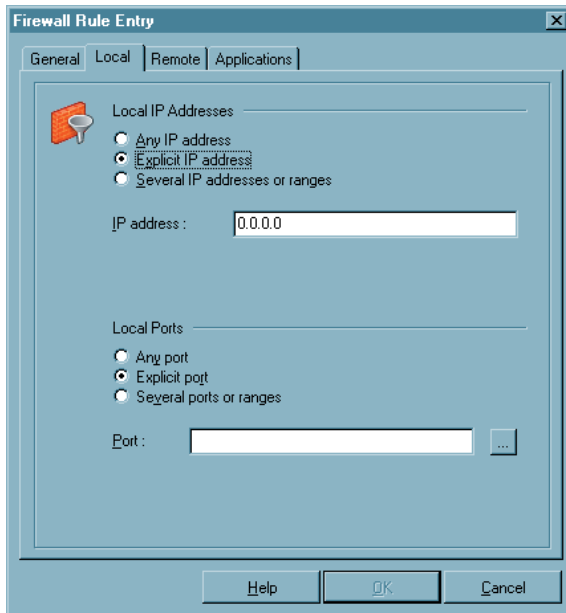

On this tab the filter are set for the local IP addresses and IP ports.

If the basic setting is blocked then those data packets will be let through to the outside by the firewall whose source address agrees with the address under “Local IP address” or is within the range of validity. Of the incoming data packets those are let through whose destination address agrees with the address under “Local IP addresses” or is within the validity area.

The same is true for blocked basic setting with the IP ports. Those data packets are permitted outside by the firewall whose source port

falls under the definition of the local port. Of the incoming data packets those are let through whose destination port falls under the definition of the local port.

### *Any IP address*

– includes all source IP addresses of outgoing packets or destination IP addresses of incoming packets, regardless of the local network adapter.

### *Explicit IP address*

– is the IP address defined for the local network adapter. It can be assigned to the address of the Ethernet card, the WLAN card, or it can also be assigned to the VPN adapter.

### *Several IP addresses*

– designates an address range or pool. For example this can be the IP address pool, from which the address assigned by the DHCP server to the client originates.

### *Any port*

– allows communication via all source ports for outgoing packets and destination ports for incoming ports.

### *Explicit port*

– This setting should only be used if this system makes a server service available (e.g. remote desktop on port 3389).

### *Several ports*

– This setting should only be used if the local ports can be combined in a range, that is required by a services that will be made available on this system (e.g. FTP ports 20/21).

## ■ Firewall rule / Remote

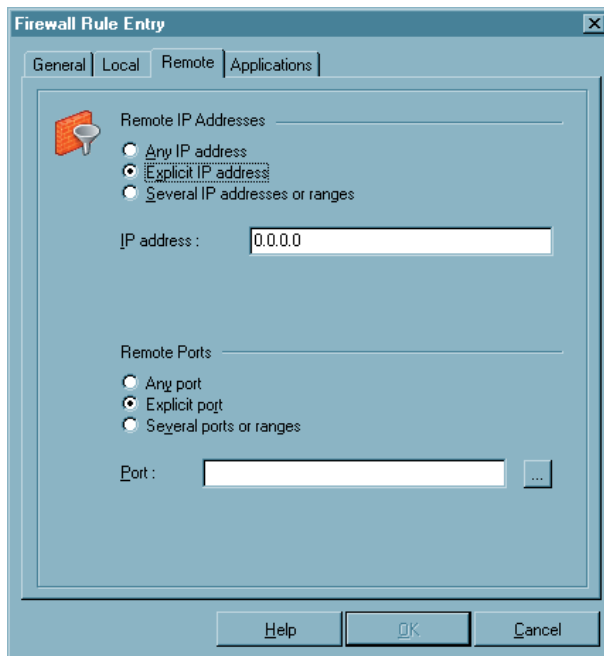

On this tab the filters are set for the remote IP addresses and IP ports.

If the basic setting is blocked then those data packets will be let through to the outside by the firewall whose destination address agrees with the address under “Local IP address” or is within the range of validity. Of the incoming data packets those are let through whose source address agrees with the address under “Local IP addresses” or is within the validity area.

The same is true for blocked basic setting with the IP ports. Those data packets are permitted outside by the firewall whose destination port falls under the definition of the local port. Of the incoming data packets those are let through whose source port falls under the definition of the local port.

With the settings under remote IP address you can specify the remote IP addresses with which the system may communicate.

### *Any IP address*

– permits communication with any IP address of the other side, without limitation.

### *Explicit IP address*

– only allows communication with the IP address on the other side specified here.

### *Several IP addresses / IP ranges*

– permits communication with different IP address on the other side according to the entries.

With the settings under remote ports, you can specify the ports via communication with remote systems is permitted.

### *Any port*

– sets no limitations whatsoever relative to destination port for outgoing packets or source port for incoming packets.

*Explicit port*

– only allow communication via the specified port, if this port if it is present al destination port in the outgoing data packet, or if it is present a source port in the incoming packet. If for example a rule only permits Telnet to a different system, then port 23 must be entered here.

*Several ports / ranges*

– can be used if multiple ports will be used for a rule (e.g. FTP port 20/21).



## ■ Firewall rule/ Applications

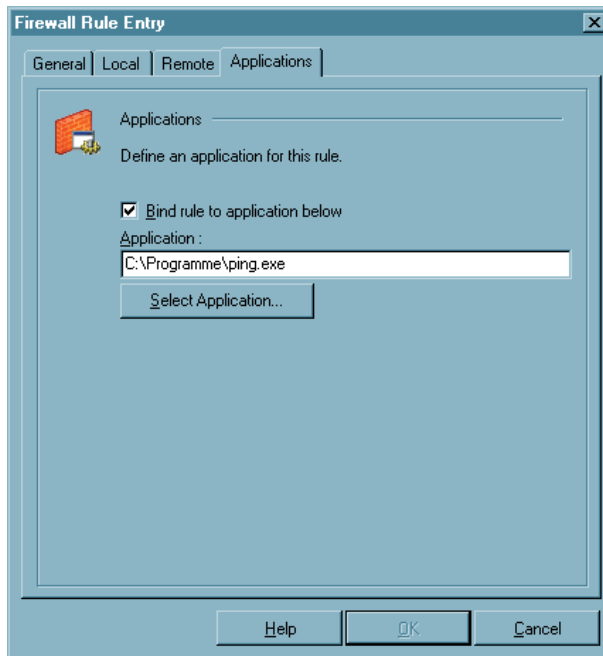

Assign rule to a certain application

– this means that with blocked (basic setting) for this application a connection is possible. It is selected via the “Select application” button a local installed application, such as ping.exe, thus only this application can communicate. In this case according to this rule only pings can be executed.

In this example you should also note that ICMP is permitted from the protocol.

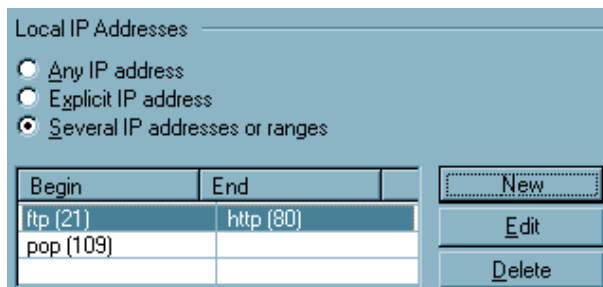

Please note that the assigned Port has als to be selected. For e-mail application port 80.

## ■ Configurationsfield Friendly Networks

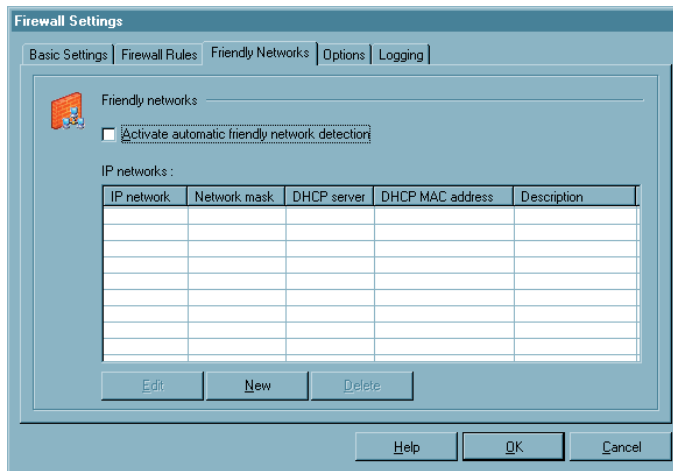

If in “Firewall rules” you have defined in the configuration field, that a rule will be applied to connections with known network, then this rule is always used, if a network can be identified as known network according to the criteria that is entered here, e.g. the LAN adapter is in a known network.

The LAN adapter of the client is considered to be in a known network if:

### [IP network and Network mask]

– the IP address of the LAN adapter originates from the specified network range. If for example the IP network 192.168.254.0 is specified with the mask 255.255.255.0, then the address 192.168.254.10 would effect an allocation to the known network.

### [DHCP server]

– the IP address has been assigned by the DHCP server that has the IP address specified here;

### [DHCP MAC address]

– if this DHCP server has the MAC address specified here. This option can only be used if the DHCP server is located in the same IP subnet as the DHCP client.

The more of these conditions that are fulfilled the more precise the verification that a known network is involved.

The allocation of an adapter to unknown or known network is automatically logged in the log window of the Client Monitor and in the log file of the firewall (see → Logging).

### Activate automatic friendly network detection

About automatic friendly network detection please refer the parameter field on the following page.

## ■ Automatic detection of Friendly Nets

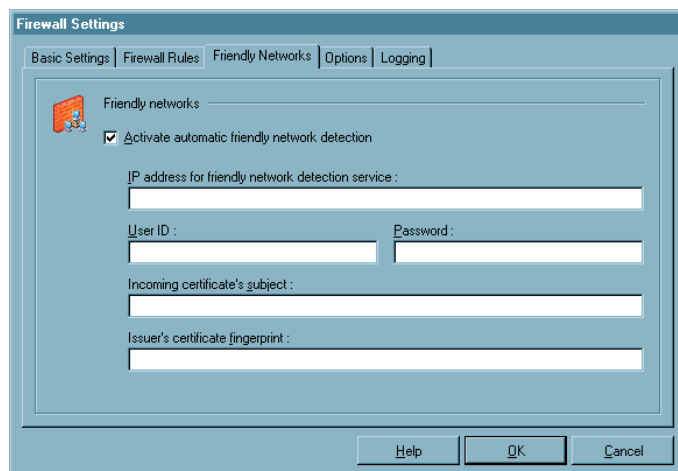

The administrator centrally specifies what constitutes a Friendly Net. A Friendly Net is indicated in the monitor by the Firewall icon, which is green as soon as the Client has dialed-in to a Friendly Net.

### IP address of the Friendly Net detection service

A Friendly Net Detection Server (FNDS) is required; this is an NCP software component that must be installed in a network that is defined as “Friendly Net”. This Friendly Net Detection Server must be reachable via IP, and its IP address must be entered here. To increase redundancy the IP address of a second FND server can be entered after the first IP address, after a comma. The IP address of the first available FND server will be selected automatically for friendly net detection.

### User ID, Password (FNDS)

The Friendly Net Detection Server is authenticated via MD5 or TLS. The user ID and password entered here must agree with those that have been stored on the FNDS.

### Incoming certificate's subject (user)

The incoming certificate of the FNDS is checked for this string. It is a Friendly Net only if there is agreement.

### Issuer's certificate fingerprint

In order to offer maximum security against counterfeiting, the fingerprint of the issuer certificate must be capable of verification. It must agree with the hash value entered here.

### *Friendly Net Detection via TLS*

If the Friendly Net will be detected via TLS, (including authentication via the issuer certificate fingerprint), then this issuer certificate must be located in the “CaCerts” program directory, and its fingerprint must agree with the fingerprint configured here.

## ■ Configurationsfield Options

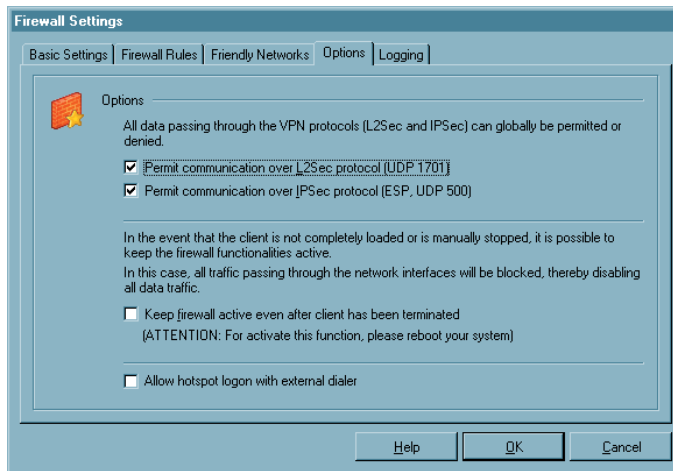

With blocked basic setting the set-up of VPN connections via the “Options” tab can be globally permitted. The following protocols and ports required for the tunnel set-up are released per generated filter:

For L2Sec:  
 UDP 1701 (L2TP),  
 UDP 67 (DHCP),  
 UDP 68 (DHCP)

For IPSec: UDP 500 (IKE ISAKMP), IP-protocol 50 (ESP), UDP 4500 (NAT-T), UDP 67 (DHCP), UDP 68 (DHCP)

This global definition saves you the set-up of dedicated single rules for the respective VPN variants.

Please note that only the tunnel set-up is enabled with this. If no additional rules exist for VPN networks, that permit a communication in the tunnel, then no data transfer can occur via the VPN connection.

### Continue to activate firewall with stopped client

The firewall can also be active if the client is stopped, if this function is selected. In this state however each incoming and outgoing communication is suppressed, so that no data traffic at all is possible, as long as the client is deactivated.

If the above mentioned function is not used and the client is stopped, then the firewall will also be deactivated.

### Allow HotSpot logon for external dialers

If this function is activated, then HotSpot logon can be executed via an external dialer. You must call the command line interface `rwscmd.exe` for this. (See the description in the “Services” Appendix in this manual for more information in this regard!) With the command

```
rwscmd /logonhotspot [Timeout]
```

the firewall will be released for ports 80 (HTTP) and 443 (HTTPS). This generates a dynamic rule that allows data traffic until the transferred timeout (in seconds) has elapsed.

## ■ Configurationsfield Logging

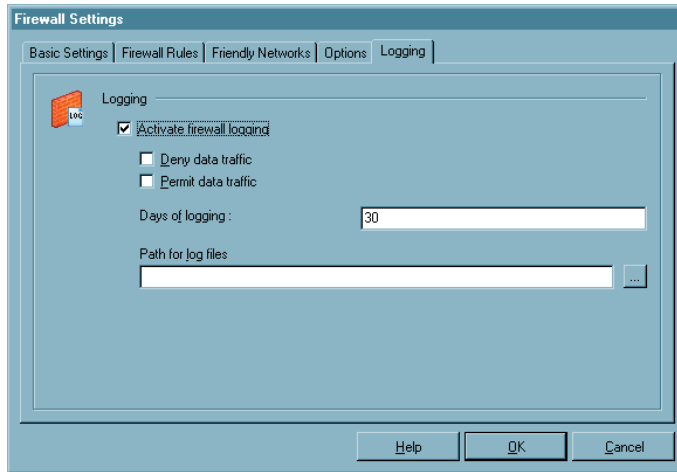

The activities of the firewall are written to log file depending on the setting. The default location of the “Output directory for log files” is in the installation directory under:

```
<windows>\ncple\log
```

The log files for the firewall are written in pure text format and are named Firewall-lyymmdd.log. They contain a description of “rejected data traffic” and or “Permitted data traffic”. If neither of these options has been selected then only status information on the firewall will be logged.

The log files are written at each start of the firewall. The maximum number is maintained in the log directory, as has been entered as number of the “Days for logging”.

Note: Activating the Logging will decrease the performance. For each packet corresponding to this setting, an according log text has to be written.

## 4.2.3 WLAN Settings

### *Integrated WLAN configuration for Windows 2000/XP*

Under Windows 2000/XP the WLAN adapter can be operated with the connection type “WLAN” (see → Phonebook / Parameters / Destination system). In the monitor menu “Configuration / WLAN settings” the access data for the wireless network can be saved in a profile.

#### ■ Search networks

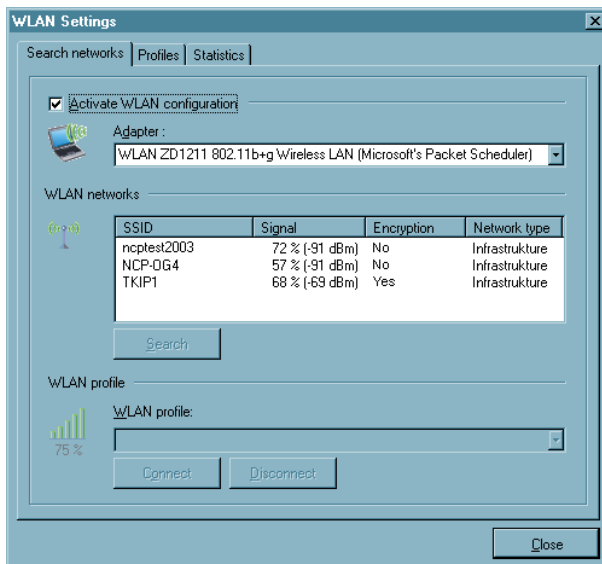

If this “WLAN Configuration” is activated, then the management tool of the WLAN card must be deactivated. (Alternatively the management tool of the WLAN card can also be used; in this case the WLAN configuration in the monitor menu must be deactivated.)

#### Adapter

If a WLAN adapter is installed, then it will be displayed.

#### WLAN networks

After an automatic scan process that takes a few seconds, (this can also be triggered manually by clicking on the “Scan” button), the currently available networks will be displayed with data on SSID, field strength, encryption, and network type. These values can be configured accordingly in an associated profile:

**SSID**  
**Field strength**  
**Encryption**  
**Network type**

The name for the SSID (Standard Security) is assigned by the network operator and is displayed under the graphic field of the Monitor, in the same manner as the field strength (Fig. below). After double clicking on the network to be selected the SSID is automatically transferred into a WLAN profile for this adapter, if a profile has not yet been created for this network (see below → WLAN Profiles / General).



## WLAN Profiles

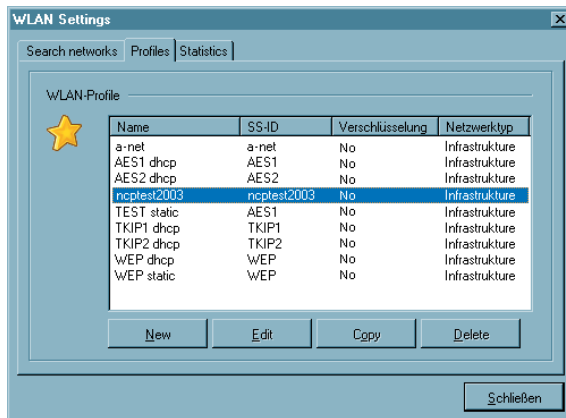

Previously created profiles for the adapter selected above are displayed in a list. Network type, encryption, and SSID must agree with the above network parameters. A new profile is generated by clicking on the “New” button, or by double clicking on the corresponding network in the previous window, or by clicking on the right mouse button. Profiles can also be edited or deleted via the buttons.

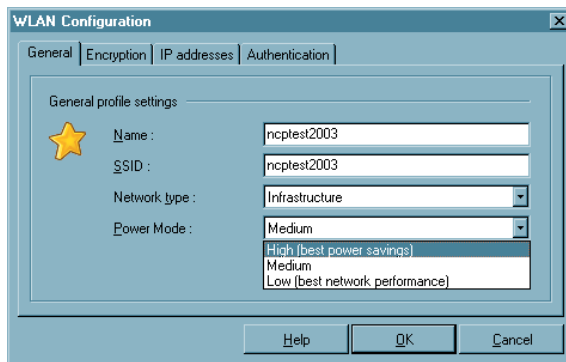

### General Profile Settings

The name can be freely assigned, and for a new profile generation after double clicking on the scanned network, it is initially identical with the SSID of this network. The procedure is the same with the network type, which must be identical with the network type that is sent in the broadcast of the wireless network.

The network type must then be switched to “Ad-hoc” manually if you want to set-up a profile for a direct connection from PC to PC. If the WLAN adapter permits this then the Energy Mode can be selected for it.

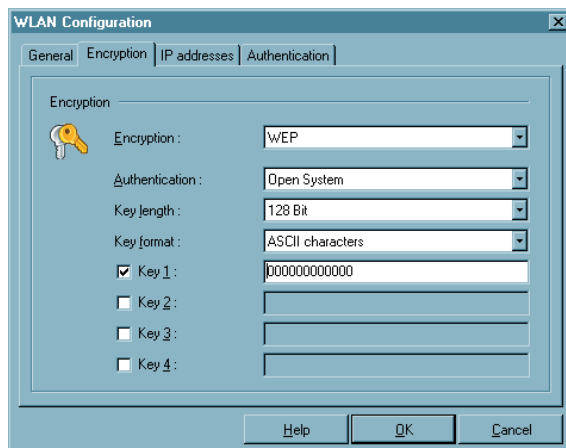

### Encryption

The encryption mechanism must be specified by the Access Point (WLAN router) and communicated by the administrator.

If WPA is used with EAP (TLS), then the EAP options must be activated in the configuration menu of the monitor and a certificate must be configured (in the monitor menu under “Configuration / Certificates”).

The screenshot shows the 'WLAN Configuration' dialog box with the 'IP addresses' tab selected. The 'IP Address' section has two radio buttons: 'Obtain an IP address automatically' (unselected) and 'Use the following IP address' (selected). Below this are three text boxes for 'IP address', 'Subnet mask', and 'Default gateway', all containing '0.0.0.0'. The 'DNS server' section has two radio buttons: 'Obtain a DNS/WINS server address automatically' (unselected) and 'Use the following DNS/WINS server addresses' (selected). Below this are four text boxes: 'DNS server' and 'WINS server' (both containing '0.0.0.0'), and 'Preferred server' and 'Alternate server' (both containing '0.0.0.0'). At the bottom are 'Help', 'OK', and 'Cancel' buttons.

## IP Addresses

Configure the IP address of the WLAN card in this window.

The settings made here are only effective if the WLAN configuration has been activated as described above. In this case the configuration entered here will be transferred into the Microsoft configuration of the network connections. (See → Network connections / Properties of Internet protocol (TCP/IP)).

The screenshot shows the 'WLAN Configuration' dialog box with the 'Authentication' tab selected. The 'Authentisierung am Hotspot' section has a dropdown menu for 'Authentication' set to 'Script'. Below this are three text boxes: 'User ID', 'Password', and 'Script file name'. At the bottom are 'Help', 'OK', and 'Cancel' buttons.

## Authentication

The access data for the HotSpot must be entered in this window. These user data are only used for this WLAN profile.

Authentication can be executed by entering user ID and password, or via script. The script automates the logon to the HotSpot operator.



Please note that there are charges associated with the connection via a HotSpot operator. You must agree to the terms and conditions of the HotSpot operator in order to set up the connection.



## Statistics

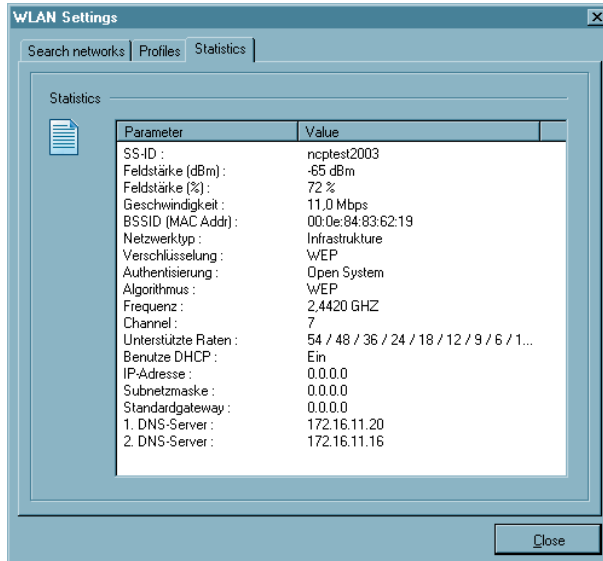

The statistics window for the WLAN settings shows the status of the connection to the Access Point in plain text.



The statistics window completes the graphical displays in the monitor with additional data. The connection state is not concerned!

## 4.2.4 Outside Line Prefix

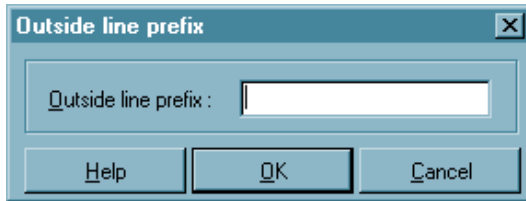

A special number or dial prefix is generally required when communicating via a PBX in order to acquire an outside line. The number entered in this field, depending on the type of PBX, will then be used for all outgoing calls until changed or deleted. This eliminates the need for modifying the destination phone number(s) in the phonebook, particularly when travelling.

The outside line prefix within the graphical user interface or the NCP logon is limited to the numbers 0 to 9 and the characters “#” and “\*”.

By entering the comma “,” you can configure a dial pause through the outside line.

## 4.2.5 Certificates | Configuration



By clicking on the menu item “Configuration – Certificates” you can first determine whether you want to use the certificates, and thus the “Extended Authentication”, and where you want to store the user certificates. The PIN entry policies and the interval of validity are specified in a second parameter field.

*Certificates are normally created by a CA (Certification Authority) utilizing some sort of PKI-based architecture and they may be implemented on a Smart Card in addition to a digital signature(s). Such Smart Cards represent an individual “personal identity card”. You can use certificates with the length of the private key up to 2048 Bits.*

*The system monitors whether the PKCS#12 file is present. If, for example, this file is stored on USB stick or an SD card, then after pulling out the SD card the PIN is reset and an existing connection is disconnected. This process corresponds to the “Connection disconnect when smart card is removed”, which can be set when using a smart card, under “Configuration, Certificates” in the monitor menu. If the SD card is later re-inserted, then the connection can be restored, after another PIN entry.*

*The environment variables (users) of the operating system can be inserted in the certificate configuration. The variables are changed when closing the dialog, and when copying the telephone book, and they are written back into the configuration. If an environment variable does not exist, then it is removed from the path when converted, and a log entry is written into the logbook. If a % sign (syntax), is missing then the variable remains, and a log entry is written, as above.*

## ■ User Certificate | Configuration

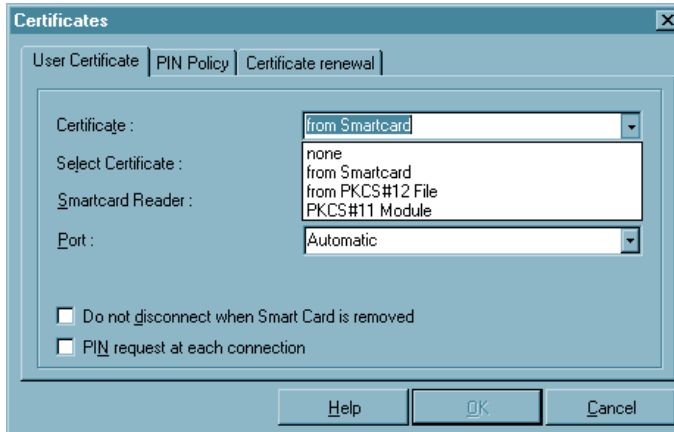

### *Certificate*

By clicking on the menu item “Configuration – Certificates” you can first determine whether you want to use the certificates, and thus the “Extended Authentication”, and where you want to store the user certificates.

The PIN entry policies and the interval of validity are specified in a second parameter field.

- None:** By choosing “Certificate” from the submenu you can determine whether or not you want to use the certificate and thus use the “Extended Authentication”. The default value is “None”.
- from PKCS#12 File:** In order to use a Soft Certificate select “from PKCS#12 File” and then define the directory (path) in which the PKCS#12 file is stored for access purposes. Normally you will receive this file (encrypted) from your network administrator or your CA (Certification Authority).
- from Smart Card:** In order to use Smart Card based Certificates select “from Smart Card” and then select the Smart Card Reader from the list of supported Smart Card Readers. (see also →Enter PIN)
- PKCS#11-Module:** Select “PKCS#11-Module” from the list in conjunction with “Extended Authentication” in order for the respective Certificate to be read from a Smart Card in a Smart Card Reader or from a Token.

## Smart Card Reader

In order to use the Smart Card's Certificate with your card reader, select the respective Smart Card reader from the list (see also →PIN Entry).

### Smart Card Reader (PC/SC conform)

The Client Software automatically supports all PC/SC conform Smart Card readers. The Client software automatically recognizes the Smart Card reader each time the PC is re-booted. Thereafter the installed Smart Card reader can be selected and used as required.

### Smart Card reader (CT-API conform)

Together with the current Client Software the following drivers are included for: SCM Swapsmart and SCM 1x0 (PIN Pad reader). In the event that the Smart Card reader does not work together the drivers that are included or another Smart Card reader is installed, then please contact the respective manufacturer. Also make the following settings in the Client Software: With an ASCII Editor edit the file NCPPKI.CONF, which is located in the Directory \WINDOWS\SYSTEM (Windows 95/98) or in the Directory SYSTEM32 (Windows NT/2000) by entering the "ReaderName" of the Smart Card reader (xyz) connected to your PC and enter as DLLWIN95 or DLLWINNT the name of the installed driver. (The default name for CT-API conform drivers is CT32.DLL).



Important: Only those drivers that have been appropriately set with "visible = 1" will be displayed in the list!

```
ReaderName = SCM Swapsmart (CT-API) -> xyz
DLLWIN95   = scm20098.dll          -> ct32.dll
DLLWINNT   = scm200nt.dll          -> ct32.dll
```

The "ReaderName" will be displayed in the Monitor Menu after re-booting.

## Port

If the Installation has been executed correctly, the card reader will automatically be assigned a port. Should problems arise, COM Ports 1-4 can be manually assigned.

## Certificate Selection

1. Certificate ... 3.: (Standard = 1) Up to 3 different certificates, located on the Smart Card, can be selected from the list. The number of certificates on the Smart Card is dependent on the Registration Authority that has issued the Smart Card. For further information please contact your System Administrator.

The Smart Cards issued by Signtrust and NetKey 2000 come with three certificates:  
 (1) for digital signing,  
 (2) for encryption and decryption,  
 (3) for Authentication (optional with NetKey 2000)

### **PKCS#12 File Name**

If you are using the PKCS#12 format, then you will receive a file from your system administrator that must be copied to your PC's hard disk. In this case enter the path and filename of the PKCS#12 file or alternatively after clicking the selection button select the file.

### **PKCS#11 Module**

If you are using the PKCS#11 format, then you will receive a DLL from your Smart Card reader manufacturer that must be copied to your PC's hard disk. In this case enter the path and filename of the driver. Instead of entering the entire directory name, it can be dynamically defined. E.g.:

```
%SYSTEMROOT%\ncple\pkcs#11.dll
%SYSTEMDRIVE%\winxxx\ncple\ pkcs#11.dll
```



**Important:** The strings for the File Name can be entered with variables. This simplifies in particular the handling of the configuration files with the Client Manager, because the same strings including environment variables can be entered for all Users.

Edit the NCPPKI.CONF file located in the Windows\system directory (under Windows 95/98) or System32 directory (under Windows NT/2000), with an ASCII editor by entering the name of the connected reader or token (xyz) as "module name". The name of the DLL must be entered as PKCS#11-DLL. The associated "Slotindex" is manufacturer-dependant (standard = 0).

```
Module name   = xyz
PKCS#11-DLL  = Name of the DLL
Slotindex    =
```

After a boot process the "Module name" you entered appears in the monitor menu if the file NCPPKI.CONF for the drivers have been set to visible with "visible = 1".



You can use an assistant to search for installed PKCS#11 modules and then select the desired module with the associated slot. For this click the button "PKCS#11-Module".

### ***Do not disconnect when Smart Card is removed***

The connection is not necessarily broken off when the Smart Card is removed. Whether “Do not disconnect when Smart Card is removed” occurs is set via the main menu of the monitor under the menu item “Configuration – Certificates”.

### ***PIN request at each manual connect***

Default: If this function is not used, the PIN request is displayed only for the first connect of the VPN/PKI Client.

If this function is activated, the PIN will be requested at each connect.



Important: If the monitor has not started, then no PIN dialog will take place. In this case, the connection will be established without renewed PIN entry in the case of an automatic connection establishment.

## ■ PIN Policy

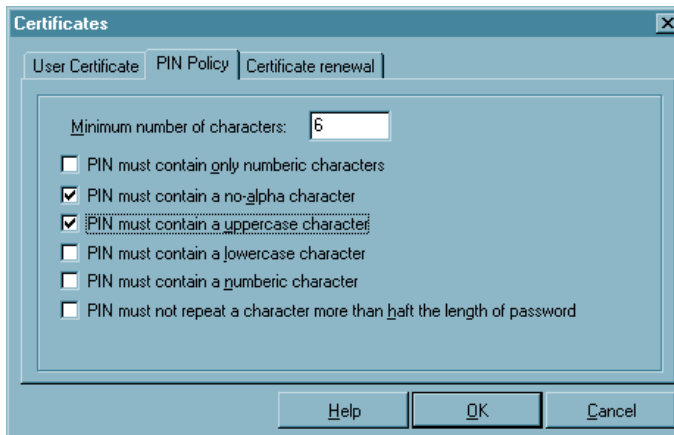

You can specify PIN guidelines that must be complied with during PIN entry or PIN modification.

### *Minimum number of characters*

Standard is a 6-digit PIN. An 8-digit PIN is recommended for security reasons.

### *Further policies*

It is recommended to implement all PIN policies, other than the one specifying that only numbers may be contained. Additionally, the PIN should not begin with a number. The specified policies are displayed when the PIN is changed, and the policies that are only fulfilled at entry are highlighted in green (see → Change PIN).

## ■ Certificate renewal

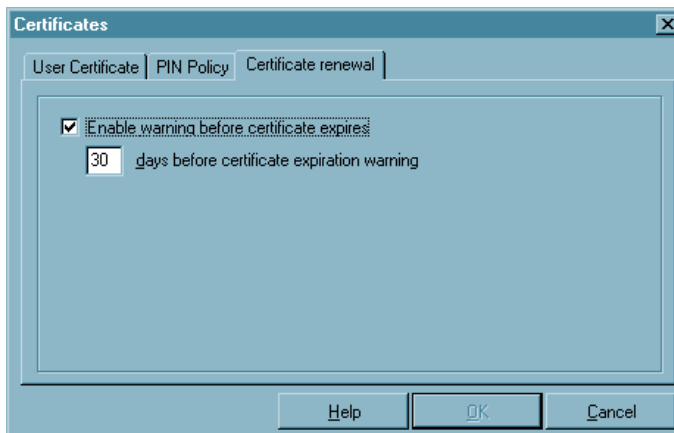

In this configuration field you can specify whether a message is given out that warns of the expiration of validity, and you can specify how many days before the certificate validity expiration this message should go out. As soon as the set time frame before expiration goes into effect, a message will appear each time a certificate is used, indicating the expiration date of the certificate.



## 4.2.6 Call Control Manager | Configuration

### External Applications

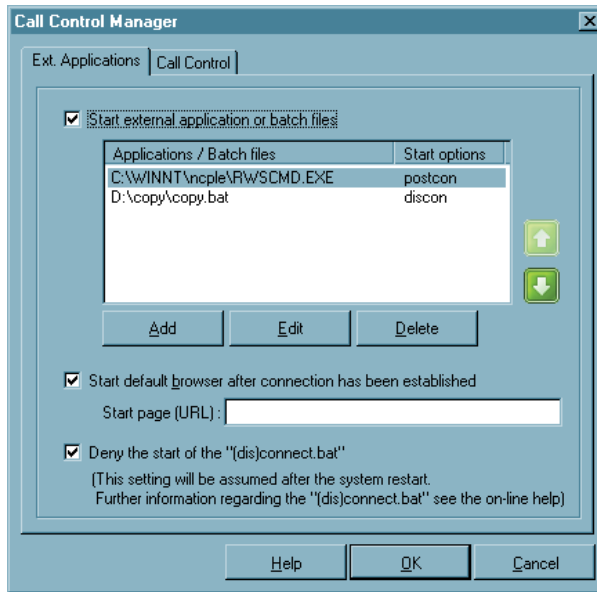

Use this configuration to start applications or batch files, depending on the Client Monitor. The external applications are added as described below. The sequence, in which they are called, from top to bottom, can be changed with the green arrow keys.

If you want to start the standard browser after connection set-up, then activate this function and enter the website of the browser.

After you have selected the function “Start external applications or batch files” you

can select an application or batch file from the computer via the “Add” button that, this application or batch file will be loaded depending on the start option.

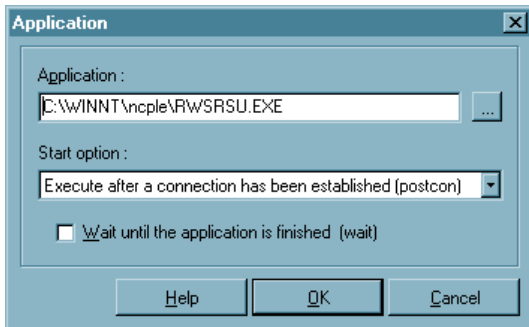

- Execute before connection has been established (precon)
- Execute after connection has been established (postcon)
- Execute after connection has been disconnected (discon)

The wait function “Wait until application has been executed and ended” can then be relevant if a series of batch files will be executed one after the other.

### Deny the start of the “(dis)connect.bat”



**This function should always be activated** if execution of the cited batch files with administrator rights (system rights) is not necessarily required for a desired application. (Please see the description in the “Services” Appendix in the manual). The applications (batch files) for which user rights are adequate, can be started in the Monitor menu “External Applications...” (see above).

## ■ Call Control

Call Control Manager

Ext. Applications | Call Control

Activate Call Control

Automatically disconnect link when limit(s) are exceeded

Display "Message" when limits are exceeded

Display "Warning" when 90% of limits are reached

Limitation period : 5 Days 0 Hrs. 0 Min.

Limit maximum time online

Max. time online : 0 Days 2 Hrs. 0 Min.

Limit maximum number of connects

Max. number of connects : 0

Limit maximum number of charge/units

Max. number of charge/units : 0

Help OK Cancel

The Call Control Manager is a feature devised to help control and limit communication costs. The following "Limit" factors can be defined:

- the maximum time online
- the maximum number of connects (outgoing calls)
- the maximum number of charge/units that may be incurred.

The time period for which these limits are to adhere to may also be defined. It is possible to define that a "Warning Message" be displayed upon reaching 90% of any limit. In the event that the set "Limit(s)" are exceeded, the link will be automatically disconnected and a "Warning Message" will be displayed in the monitor. Any further communications is denied until the "Call Control Reset" is activated (see → "Connection" pull-down menu in the monitor).

## 4.2.7 EAP Settings

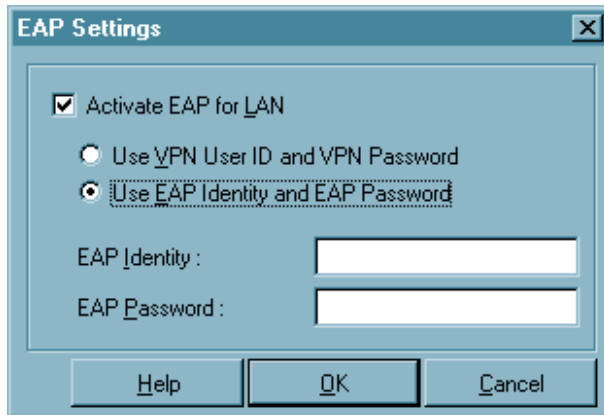

Use of the Extended Authentication Protocol Message Digest version 5 (EAP MP5) can be specified via the main menu of the monitor under “Configuration – EAP Settings”. This protocol can then be used if a switch, a hub, or if an access point is used, which support 802.1x and the according Authentication Mode for the access to the wireless LAN.

You can prevent unauthorized users from getting into the LAN via the hardware interface with the Extended Authentication Protocol (EAP MP5).

You can use either “Username” with “Password” (from the configuration field “Identity”) or your own “EAP User ID” with an “EAP Password”.



Certificate content can be automatically transferred if in the Phonebook under “Tunnel parameters” VPN User ID and VPN Password are transferred from the certificate, and if “Use VPN User ID and VPN Password” is activated in the EAP options.



Double click on the EAP icon to reset the EAP. Subsequently a new EAP negotiation will be executed automatically. If there is successful authentication relative to a network component, the other side will respond back specifying which protocol (MD5 or TLS) was used.

## 4.2.8 Logon Options



The menu option Logon options appears only for Clients using the Windows NT/ 2000 and Windows XP operating systems. (You will find the corresponding parameter for logon to a remote network under Windows 95/98 in the parameter field “Line Management” under “Logon on the network”). The logon options are only effective when the computer has booted.

Please note that the NCP Gina must have been installed in order to use this menu option. Normally this occurs when the Client software has been installed, however it can also be installed retroactively with the program `rwscmd.exe`. Please see the Appendix “Secure Client Services” for more information in this regard.

### ■ Logon

Because the connection setup to the gateway occurs prior to the Windows logon, the logon to the remote domain is already encrypted and the firewall is activated.

#### Show connection dialog befor Windows logon

The NCP Gina dialogs can be hidden via the Monitor menu without de-installing the Gina. Thus Gina concatenations that may possibly be necessary for the respective work environment remain intact. If you want to display the Gina dialog, then note that the NCP Gina must be installed in any case. This can be done in three ways:

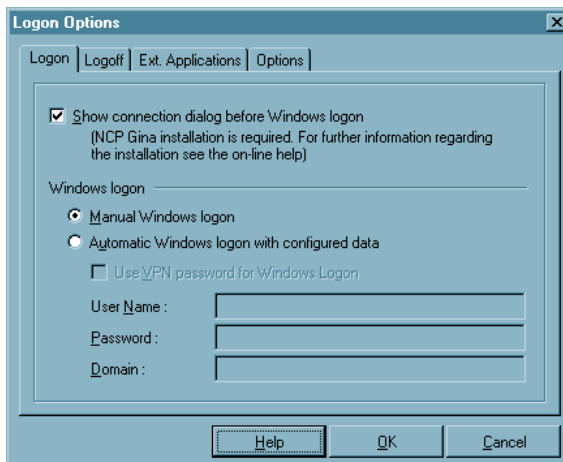

- With the software installation, here the system asks the user if he wants to use the Windows logon via the NCP Gina. If yes, it will be installed.
- Retroactive installation is possible via the command line interface `rwscmd.exe`, likewise retroactive de-installation is also possible.
- The Gina is also installed if an appropriate phonebook is provided via Secure Enterprise Management.

If the Gina dialog does not appear then the connection to the domain server cannot be set-up via the NCP Gina. In other words you must have the “Display dialog for connection before Windows logon” so that in the boot phase the connection to the VPN gateway can already be set-up. For this connection set-up you must enter access data for the network dial-in, or PIN and SIM PIN must be entered before the Windows logon.

## Windows logon

The following Windows logon can be executed automatically or manually depending on configuration.

“Execute manually” means that the user must enter his logon data manually in the Windows logon screen.

“Automatically” means that the Client software will transfer the data entered here to the Microsoft Gina without user intervention.



If you use the logon option with callback then “Negotiate PPP callback” must be activated (see → parameter field “Callback” in the Phonebook).

To select the destination with the logon option please see the section “Setup a connection - Client logon” and the Appendix for Mobile Computing.

## Logoff

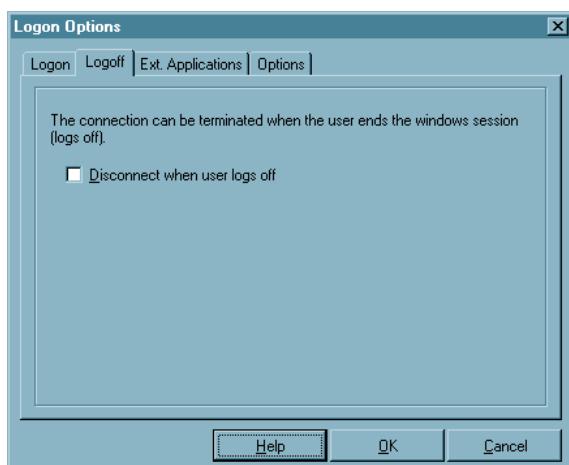

The Client connection to the VPN Gateway or ISP can be maintained when a Windows logon is executed.

This permits a change of Windows users on the computer, without having to disconnect the VPN connection.

## External applications

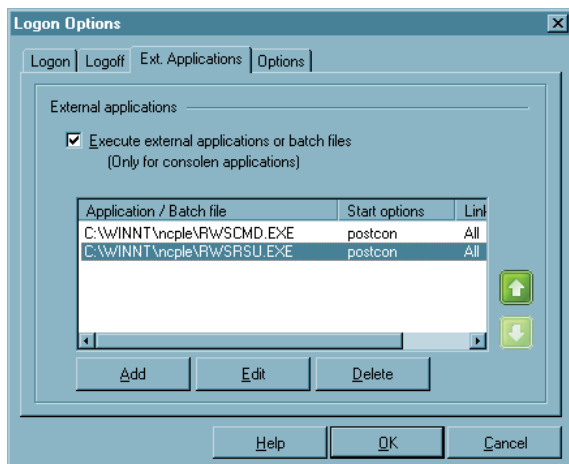

Use this configuration field to start applications or batch files, depending on the Client Monitor (no Windows programs!).

The external applications are added as described on the next page. The call sequence from top to bottom can be changed with the green arrow keys.

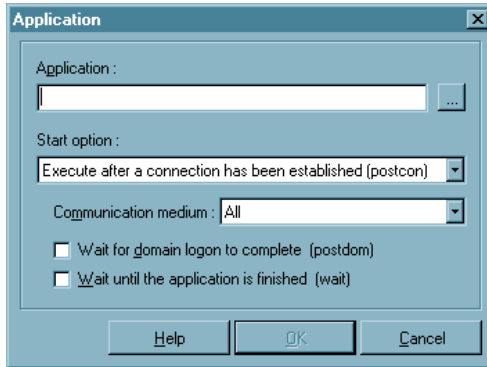

After you have selected the function “Start external applications or batch file” you can select an application or batch file from the computer (see previous page), this application or batch file is then loaded depending on the start option:

- Execute before a connection has been established (precon)
- Execute after a connection has been established (postcon)

In addition, the application can be started depending on the connection type of the destination system that is selected in the Gina dialog. The application always starts if the connection type “All” has been selected.

“Wait for domain preparation (postdom)” means that after the initialization period, the application will be started immediately. The wait function “Wait until application has been executed and ended” can then be relevant if a series of batch files will be executed one after the other.

## ■ Options

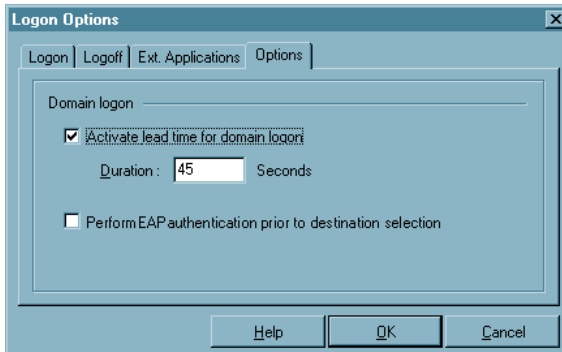

Windows requires a certain initialization time between network logon and domain logon. This preparation time for the domain logon can be activated and set here. The Windows logon will only be executed after the connection setup, after the initialization time set here has elapsed. The standard value is 45 seconds and can be changed as needed.

### Perform EAP authentication prior to destination selection

The standard situation is that EAP authentication takes place prior to establishing the connection to the VPN gateway. If EAP will be used without subsequently setting up a connection via the Client (pure EAP Client) then this function must be activated. If EAP with certificate is implemented, then the PIN dialog for authentication appears on the network components. Thereafter the destination can be selected. If the function is not activated then EAP authentication will only be executed after the destination has been selected.



Using the Logon Options refer also the appendix “Mobile Computing via GPRS/UMTS”.

## 4.2.9 Configuration Locks

Use configuration locks to modify the configuration main menu in the monitor in such a way that the user can no longer modify the pre-set configurations, or so that selected parameter fields are no longer visible for the user.



The configuration locks are enabled after applying the defined settings with “OK”. Clicking the cancel button the default settings will be used.

### ■ General | Configuration Locks

In order to effectively specify the configuration blocks, identification must be entered, which consists of “User ID” and “Password”. The password must be confirmed thereafter.

Please note that identification is absolutely necessary for the configuration block, in order to activate the blocks, or to cancel the configuration blocks. If the identification is forgotten there is no other possibility to cancel the blocks!

Now authorization to open menu items under the main menu item, “Configuration”, can be limited for the user. As standard, the user can open all menu items and edit the configurations. If the check mark is removed from the respective menu item with a mouse click, then the user can no longer open this menu item.

## ■ Profiles | Configuration Locks

The editing rights for the parameters in the profile settings are divided into two groups:

- General rights
- Visible profile parameter fields

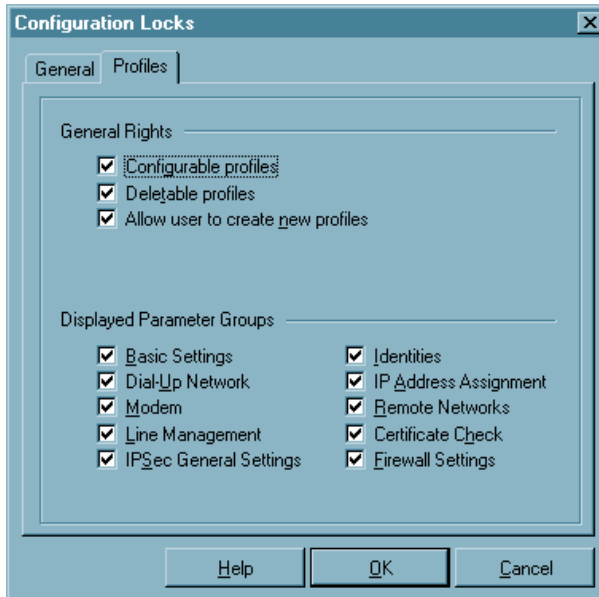

### *General rights*

The general rights refer only to (configuration of) the profiles. If you specify “Profiles may be created”, then “Profiles may be configured”, however remains excluded, thus while new profiles can indeed be defined with the assistant, subsequent modification of individual parameters will then no longer be possible.

### *Visible profile parameter fields*

The parameter fields of the profile settings can be suppressed for the user.



Please note as well that parameters of a non-visible field cannot be configured.

## 4.2.10 Profile Import

With this function profile settings can be imported by the client. The profile settings to be imported can be created as INI-file by the destination system or edited by hand. You will find the files IMPORT\_D.TXT and IMPORT\_E.TXT in the installation directory for example. In those files the syntax and the values of the parameters are described.



## 4.2.11 Profile Settings Backup

If a secure profile setting has not yet been generated, for instance in the case of a first installation, then a first profile setting (NCPPHONE.SAV) will automatically be created.

### ■ Create

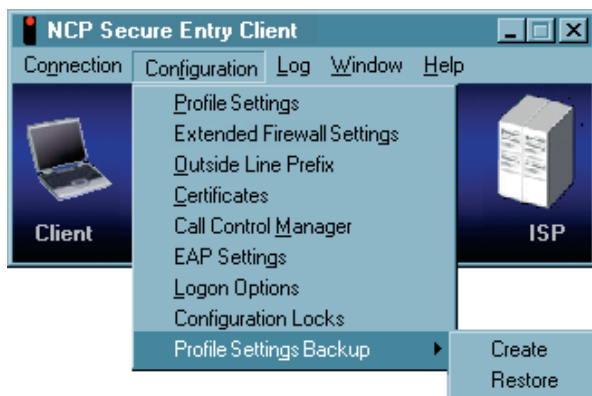

A profile setting backup will be created after each click on the “Create” menu item, and after a confirmation question, that contains the configuration up to this point.

### ■ Restore

The last profile setting backup will be read in after each click on “Restore”. Thus, changes in the configuration that have been made since the last profile setting backup will be lost.

## 4.3 Log



This feature automatically logs (records) all communication transactions (but not the data) going via the Client. Selecting the Log function will open the window of the logbook.

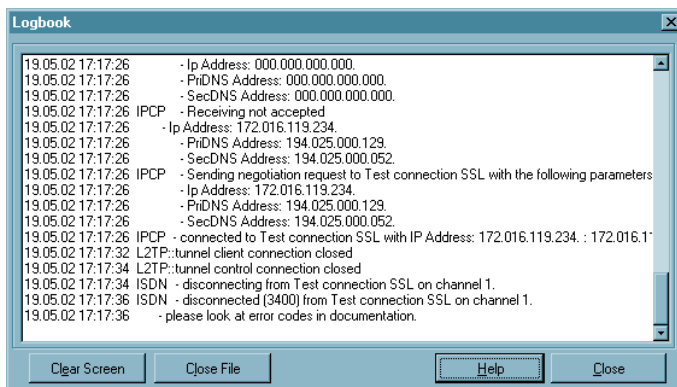

The contents of the log are stored in memory and are accessible until such a time that you (re)boot your PC.

Alternatively, if required, the log can also be written (stored) to a file. The log function automatically stores all actions of the Client for a period of seven days. Log files older than 7 online days will be automatically deleted. This is where the log files are stored and are named NCPyymmdd.LOG (yy=year, mm=month, dd=date). The file can be opened and analyzed with a text editor.

### ■ Logbook

The buttons of the “Logbook” window have the following functions:

- Create File
- Close File
- Clear Screen
- Close – Logbook

### Create File

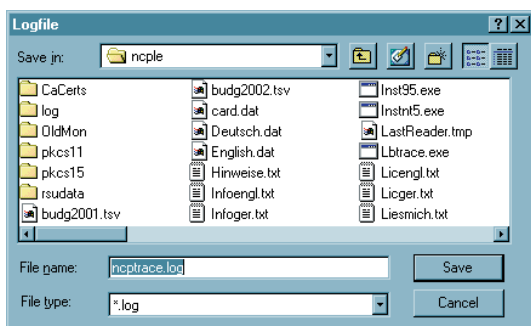

Clicking this button will open a window where you can enter the name and path of the file to be created for the log feature to write (record) to (default name = ncptrace.log).

All communication transactions (but not the data) will then be written to the file until such a time that the “Close File” command is initiated. Creating a log file will enable you to make a more detailed review or analysis of your communication transactions over a longer period of time.

### ***Close File***

Clicking on the “Close” button will close the file that was established with “Create File”. Once the file has been closed it can then be used to make a detailed review or analysis of the communication transactions that have been stored.

### ***Clear Screen***

Clicking this button will delete the contents of the log screen and empty the buffers.

### ***Close – Logbook***

When you click on “Close” the logbook closes and returns to the monitor. Any recorded data remains unchanged.

## 4.4 Window

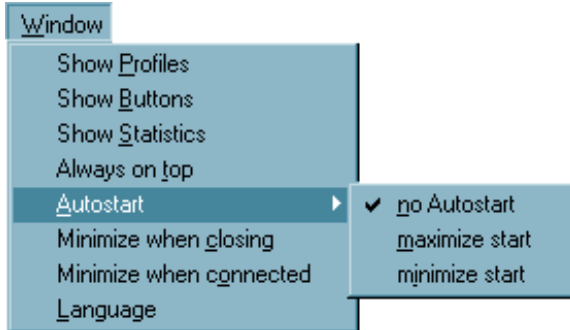

*This feature lets you influence the way in which the monitor is displayed on your screen.*

### 4.4.1 Show Profiles

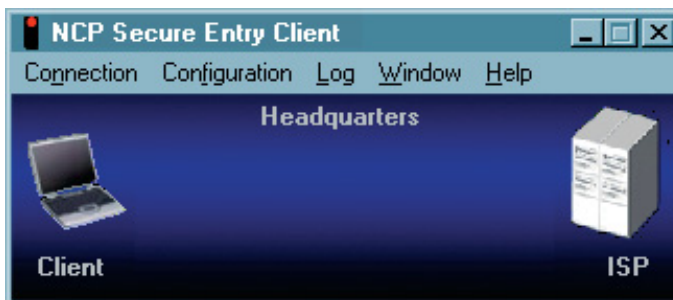

Left side the minimized representation.

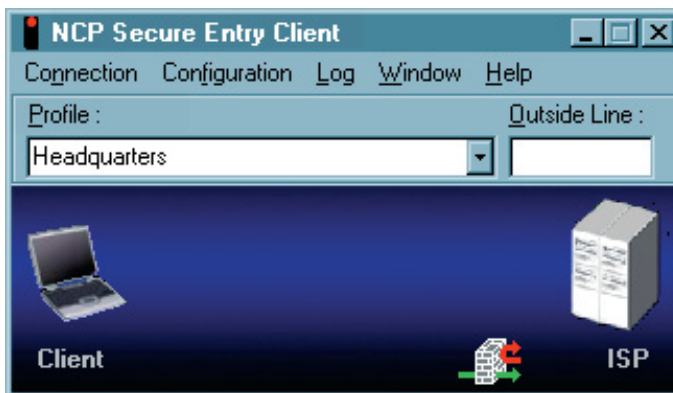

When “Show Profiles” is activated the configured destinations could be selected by clicking on the listed names (picture left side).

## 4.4.2 Show Buttons



When “Show Buttons” is activated the buttons concerning to “Connect” and “Disconnect” are displayed therefore the size of the window is larger.

## 4.4.3 Show Statistics

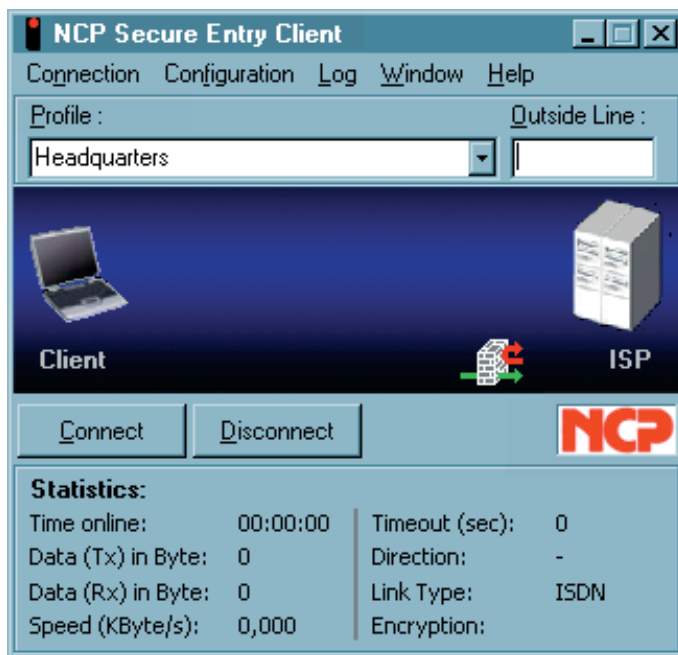

When “Show Statistics” is activated all information available from the monitor is displayed; the size of the window will be larger.

## 4.4.4 Always on top

When “Always on Top” is activated the monitor will always be displayed in the foreground of your desktop regardless of what application is currently active.

### 4.4.5 Autostart

This menu item allows to set the monitor to be started after booting. Use this menu item to set the following options:

- no Autostart: after booting do not automatically start the system
- minimize start: after booting start the monitor and minimize the display
- maximize start: after booting start the monitor and display it in its normal size



If you require the use of the IPSec client often and need the information displayed on the monitor, you should select the Autostart option “maximize start”. It is, however, not mandatory for communicating with the destination to start the monitor.

### 4.4.6 Minimize when closing

If the monitor is closed during an existing connection via the close button [x] in the upper right hand side of the (active) titel bar [Alt + F4], then a message window alerts you that no icon (tray icon) will appear in the task bar, this means that the user then cannot recognize on his screen whether connection charges are accruing, how long connection charges will accrue, or whether the connection has already ended.

(In this case, the monitor must be restarted to determine the status of the connection and to correctly end the connection.)

The “Minimize when closing” menu item has been added under “Window”. If this menu item is active, then the monitor is only minimized when closing via the [x] in the (active) titel bar or via [Alt + F4]. Clicking on the close button [x] in the header has the same effect in this setting as clicking on the minimize button [-] in the (active) titel bar.

(The possible destination system can be read and the connection can be established or terminated with a right mouse click on the icon, or the monitor can also be ended if the connection is terminated.



By clicking “Disconnect” in the connection menu the monitor can be terminated.

### 4.4.7 Minimize when connected

If this menu item is activated the monitor will be minimized when the connection is established successfully.



Closing the monitor is only possible via the main menu “Connection – Exit”.

### 4.4.8 Language

The client software has been designed for international language support. The default language is English. In order to choose a language, click on “Language” in the Window pulldown menu and then select the desired language. In the near future the client will have additional language support.

## 4.5 Help

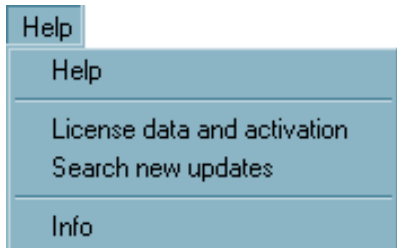

Select the “Help” menu option to open the online help context-independently with Table of Contents and Index. Moreover you can enter the license key and read the version number of the software here.

### 4.5.1 License Data and Activation

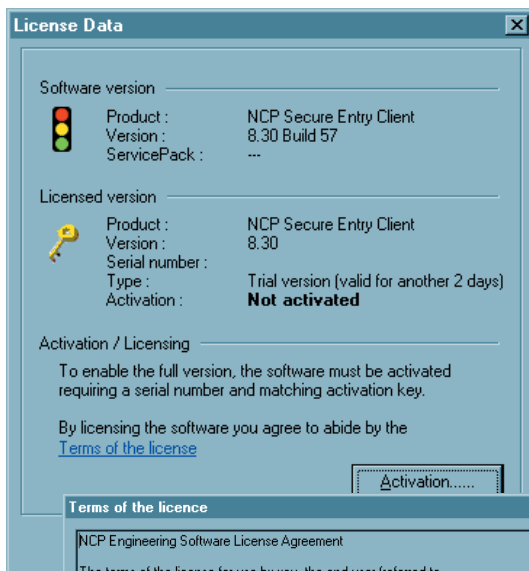

The software version implemented, and possibly the licensed version with serial number, are shown under the menu option “License Data and Activation”.

If the software is used as a test version, then the remaining validity period is displayed in the popup.

In order to use a valid full version that is not subject to time restrictions, the software must be released with the license key and serial number received.

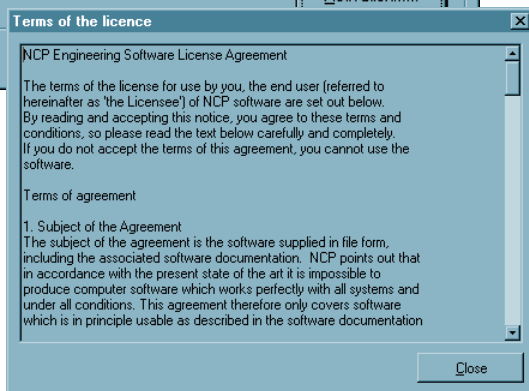

The licensing process for the software requires your acceptance of the license conditions; these conditions can be viewed via mouse click.

The license data can be entered either online or offline via an assistant. Please refer to the chapter “Licensing”.



License key and serial number can be entered after you have clicked on the licensing button.

Later the correctly entered license data is no longer displayed at this point.

## 4.5.2 Search new Updates



Use this menu option to check whether updates are available for the software (test versions as well). For more information see the “License” section below.

## 4.5.3 Info

The info window shows the product designation and the version number of the software you are using.

## 4.6 Licensing

In the “Help” Monitor menu, under the menu option “License Data and Activation”, the software version implemented, and possibly the licensed version with serial number, are shown.



The Client software is always installed first as a test version, if Client software has not yet been installed, or if there is a previously installed older version, then the software has not yet been activated. This also applies if the older version has already been licensed – then this older version will be reset to the status of a test version, and the license data must be re-entered within 30 days via the activation dialog.

The time remaining until software activation, i.e. the validity period of the test version, is displayed in the message bar of the monitor next to the activation button.

In order to use a full version with no time limitations the software must be released in the activation dialog with the license key and the serial number that you have received. With activation you accept the license conditions that you can view in the activation dialog after clicking on the appropriate button.

The activation dialog can be opened via the activation button in the message bar of the monitor, as well as the via the monitor menu “Help / License info and activation”. The license data can be entered either online or offline via a wizard.

In the offline variant, a file that is generated after entering the license key and serial number must be sent to the NCP web server, and the activation key that is then displayed on the website must be noted. This activation key can be entered in the licensing window of the Monitor menu at a later point in time.

In the online variant, an assistant forwards the licensing data to the web server immediately after entry and thus the software is immediately released.

## 4.6.2 Test Version Validity Period

The test version is valid for 30 days. Without software activation or licensing it will no longer be possible to setup a connection after this 30-day period expires.

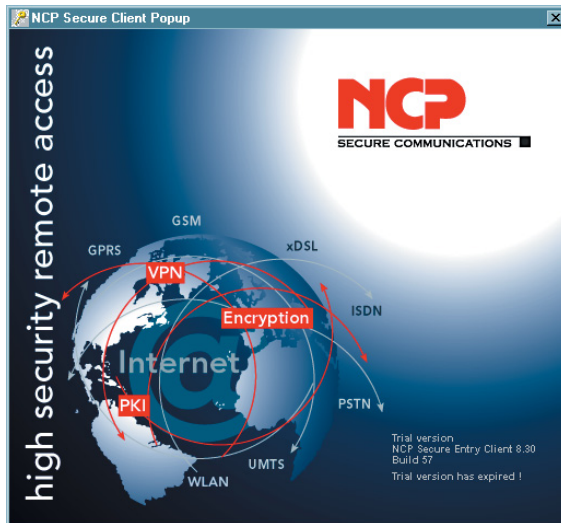

After installation, each time the software is started the validity period will be shown in the popup window. Moreover in a footer of the Monitor the system will display how long the test version can still be used, and when 10-days validity remain, a message box will be displayed to remind you that the software has not yet been licensed. This message box will appear once a day.

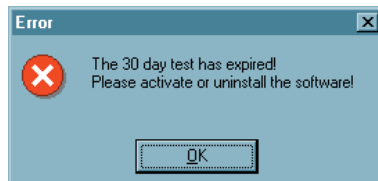

If the test phase has expired, then only those connections to destination systems can be setup with the Entry Client software that are used for software activation/licensing. Thus one of the profiles of the Entry Client can be used to set-up an Internet connection for licensing purposes. Or a connection to the NCP Secure Enterprise Management can be established in order to download a licensed version of the software.

## 4.6.2 Software Activation

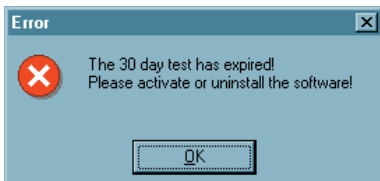

At the latest when the test phase has expired the software must be either activated or de-installed. For activation, select the menu option “License info and activation” in the monitor menu “Help”.

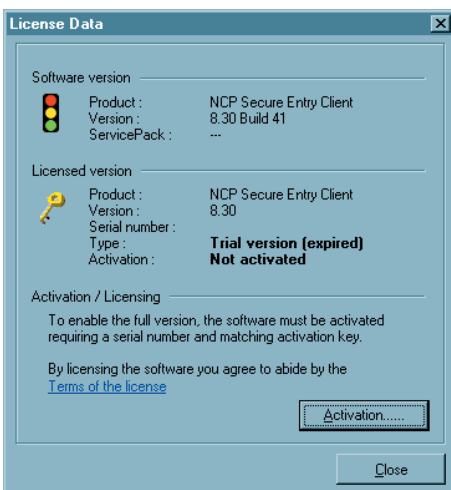

Here you can see which software version you have and how the software is licensed, i.e. you can see that the test version has expired and that the software has not yet been activated/licensed.

Click on the license conditions to display the license agreement text. By activating/licensing the software you accept the license conditions.

Click on the “Activation” button to license the software.

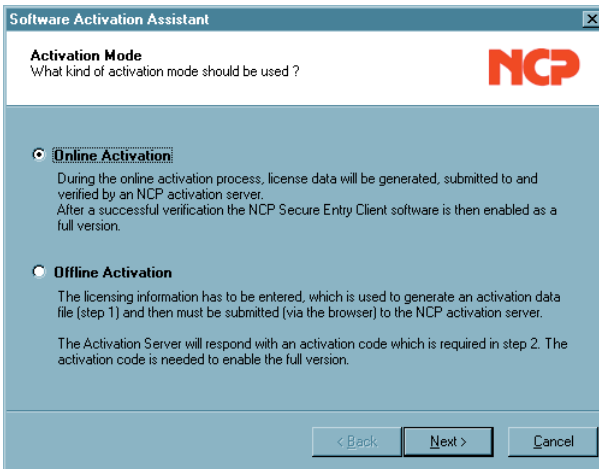

In the window that appears you can select an online variant or an offline variant.

In the offline variant, a file that is generated after entering the license key and serial number must be sent to the NCP web server, and the activation key that is then displayed on the website must be noted. In the online variant, an assistant forwards the licensing data to the web server immediately after entry and thus the software is immediately released.

After selecting the type of activation the license data will be entered in the appropriate fields. Click on “Next”!

With the online variant the license data will be transmitted to the NCP Activation Server via an Internet connection. This Internet connection can either be established via the Data Communications Dialer, via DSL, or via the Entry Client.



If the Internet connection is not set-up via the Entry Client, then the connection must first be established in order to then start the activation assistant via the Monitor menu option, “Help” / License info and activation”.

If the Entry Client is used to set-up the connection on the Internet, then a suitable profile must first be established for the Entry Client. Ensure in this regard that port 80 is released (for HTTP) if the firewall is activated. (If a proxy server will be configured in the operating system, then these settings can be transferred.)

After the profile has been selected, click on “Next”.

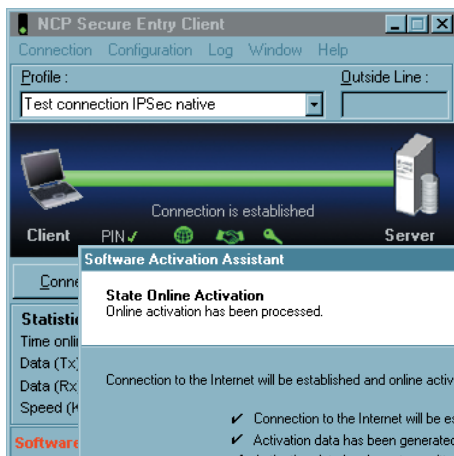

The Internet connection via the Entry Client does not have to be set-up prior to activation. It is set-up automatically after the desired existing profile has been selected in the assistant for software activation, and after clicking on the “Next” button.

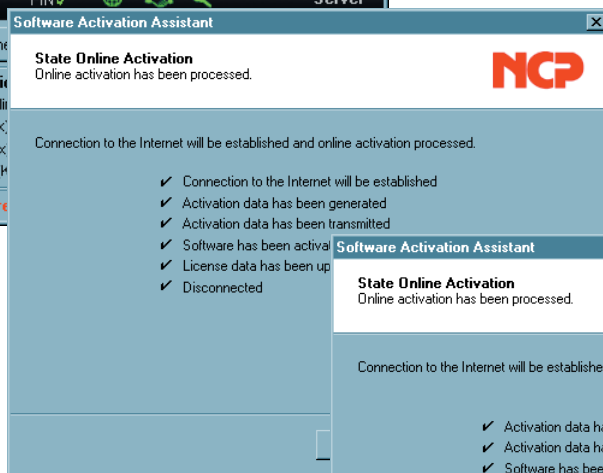

The software is activated automatically in the specified sequence.

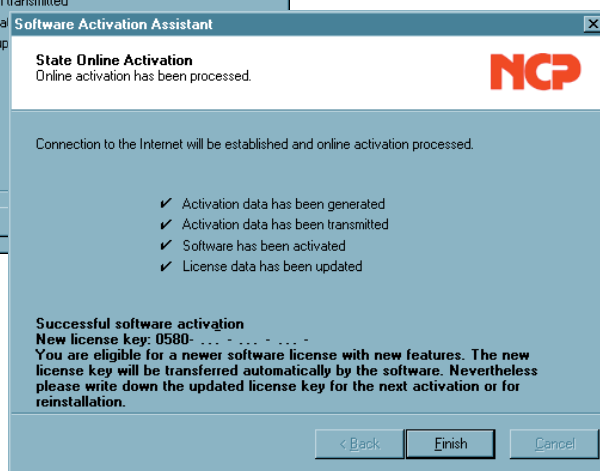

As soon as the Activation Server detects that you are entitled to a newer software license and that the license key agrees with the installed software, then with online activation the new license key will be transferred automatically (license update), and thus the new features of the software will be released.\*

\* Please see the section “Updates” at the end of this section for more information in this regard.

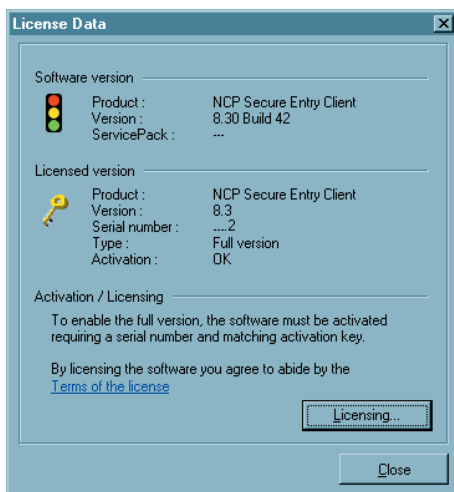

After concluding the activation process, in the window for the license data you can see that you now have a correctly activated full version.

The number of the software version and of the licensed version can differ if the licensing is only valid for an older version, otherwise the licenses must be updated with a newer license key. To do this click on the “Licensing” button. See the description at the end of the offline variant for more information in this regard.

## ■ Offline Variant

The offline variant is executed in two steps. In the first step a file that is generated after entering the license key and serial number is sent to the NCP Web Server. The URL is:

```
http://www.ncp.de/english/services/license
```

Then an activation key will be shown on the web site, and you must note this number in order to enter the license key in the licensing window of the Monitor menu in a second step, which can also be executed at a later point in time.

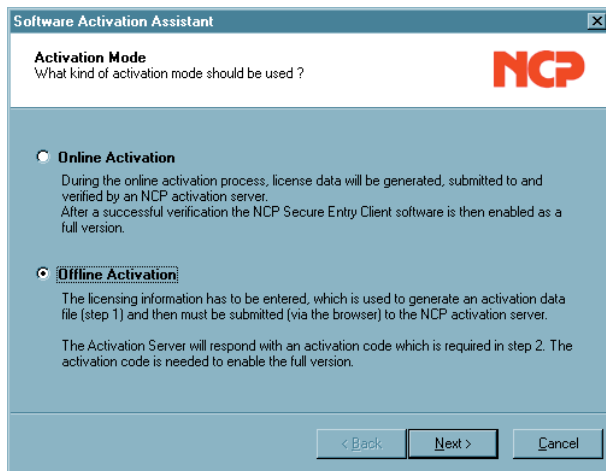

Start the offline variant via the monitor menu “Help / License Data and Activation”, and select this variant in the first window of the Activation Assistant. Click on “Next”.

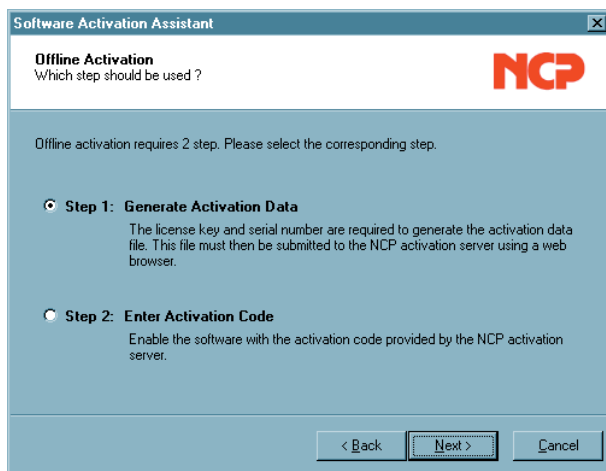

In the second window of the Activation Assistant the two steps of the offline activation process are explained. The first step, creation of the activation file is selected automatically. Click on “Next”!

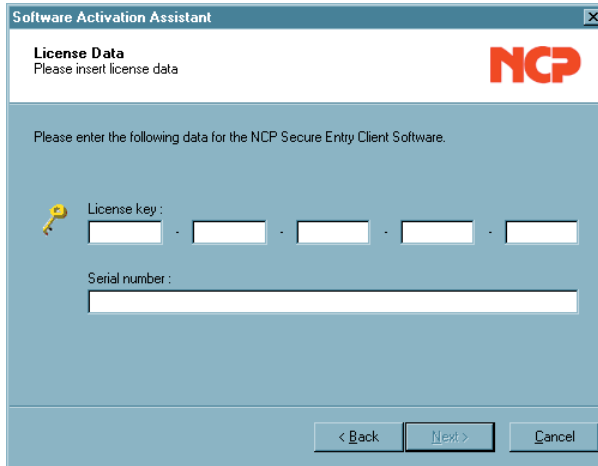

**Software Activation Assistant**

**License Data**  
Please insert license data

Please enter the following data for the NCP Secure Entry Client Software.

License key :  -  -  -  -

Serial number :

< Back   Next >   Cancel

In the following window enter the license data and click on “Next”.

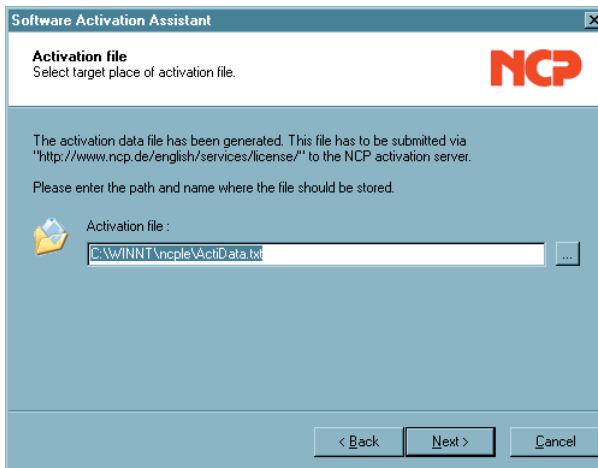

**Software Activation Assistant**

**Activation file**  
Select target place of activation file.

The activation data file has been generated. This file has to be submitted via "http://www.ncp.de/english/services/license/" to the NCP activation server.

Please enter the path and name where the file should be stored.

Activation file :  ...

< Back   Next >   Cancel

Enter name and path for the activation file. The default is the installation directory of the software and the name ActiData.txt (with serial number).

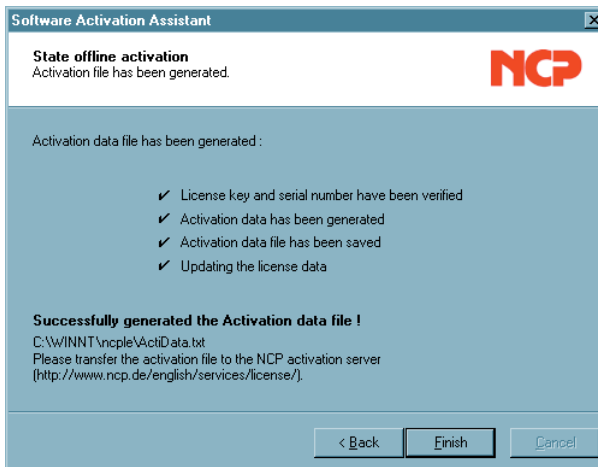

**Software Activation Assistant**

**State offline activation**  
Activation file has been generated.

Activation data file has been generated :

- ✓ License key and serial number have been verified
- ✓ Activation data has been generated
- ✓ Activation data file has been saved
- ✓ Updating the license data

**Successfully generated the Activation data file !**  
C:\WINNT\ncple\ActiData.txt  
Please transfer the activation file to the NCP activation server  
(http://www.ncp.de/english/services/license/).

< Back   Finish   Cancel

Now the activation file is created and this file must be transferred to the Activation Server.

For this the NCP web site must be called:

<http://www.ncp.de/english/services/license>



Partner Area  
 Knowledgebase  
 IPSec compatibility  
 CE compatibility  
 Trainings  
 Download  
 Current Versions  
 Trial Software  
 Software for registered users  
 Manuals  
 Data Sheets  
 Whitepapers  
 Brochures  
 Newsletters  
 Feedback

## Software activation

Please copy the content of the activation file that is generated by the NCP Secure Client (**offline activation, step 1**) into the text field that is provided for it. Click on the "Send" button to transmit the file to our activation server.

Alternatively you can also upload the activation file directly to the activation server. To do this, click on the "Browse..." button and select the file with the activation data. Click on the "Send" button to transmit the data to our activation server.

After sending the activation data, or the file, you will receive an **activation code**. Continue the software activation process in the NCP Entry Client by opening the monitor menu (Help ? License info and activation ? Offline activation). Under **step 2** the **activation code** displayed below will be queried. This step concludes the software activation process.

### Content of the activation file:

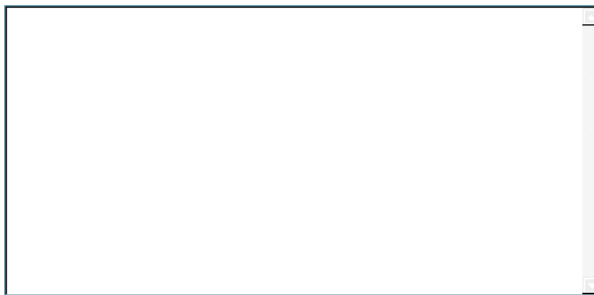

Filename :

C:\WINNT\ncple\ActiData.txt



high security remote access

There are two ways to transfer the activation file to the Activation Server. Either copy the content of the activation file with Copy & Paste, after you have opened the activation file with the Notepad (ASCII editor), into the window that is open on the web site, or click on the "Browse" button and select the activation file. Click on "Send"!



SECURE COMMUNICATIONS

[Partner Area](#)
[Knowledgebase](#)
[IPSec compatibility](#)
[CE compatibility](#)
[Trainings](#)
[Download](#)
[Current Versions](#)
[Trial Software](#)
[Software for registered users](#)
[Manuals](#)
[Data Sheets](#)
[Whitepapers](#)
[Brochures](#)
[Newsletters](#)
[Feedback](#)

## New Activation Code

Activation Code: TITXTE

New License Key: 3005

The Activation Code was successfully generated. Our system, however, has detected that you are eligible for a newer software license. In order to use the latest features, please, finish the activation procedure and use the License Key above.

In order to finish the software activation, please, note the activation code above and proceed with **Offline Activation** under the menu item "Help → License info and activation" **Step 2**. After completing the activation enter the new License Key under the same menu item "Help → License info and activation".

E-Mail: [support@ncp.de](mailto:support@ncp.de)



high security remote access

Then the activation code will be generated and displayed on the web site. Note the activation code and continue the activation process under the menu option "Help" / License info and activation", by executing the second step of the activation in the offline variant.

IF the Activation Server detects that you are entitled to a newer software license and that the license key agrees with the installed software, then with the online activation the new license key will be displayed automatically. If you want to activate the new features then note the new license key, conclude the activation process, and then use the new license key. (Please see the section "Scenarios" at the end of this section for more information in this regard.)

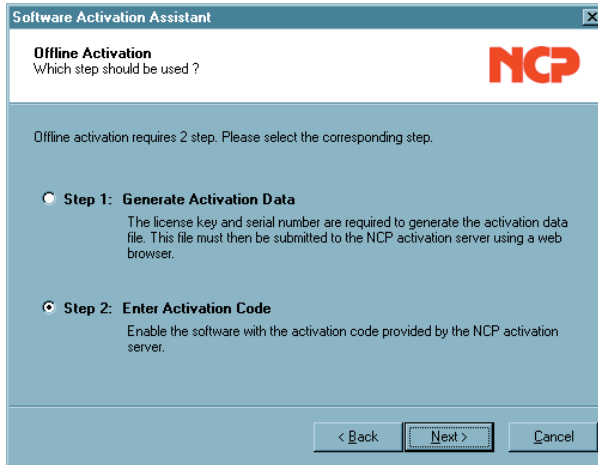

The second step of the offline variant is triggered via the Monitor menu “Help” “License info and activation”. After the offline variant has been selected, select the second step.

An Activation Assistant window will open where you can enter the activation code. After you have entered the activation code you can click on “Next”.

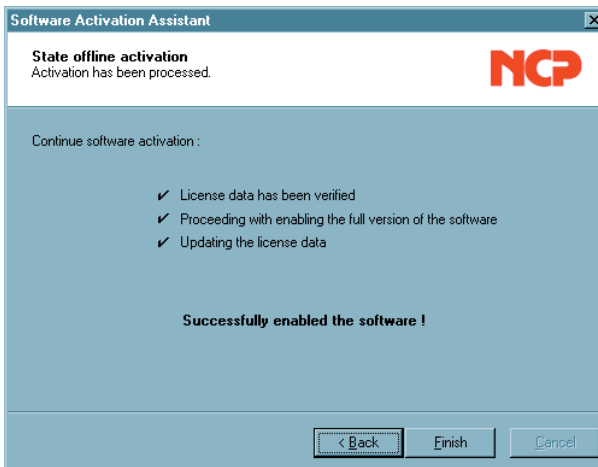

Offline activation is concluded with the following window.

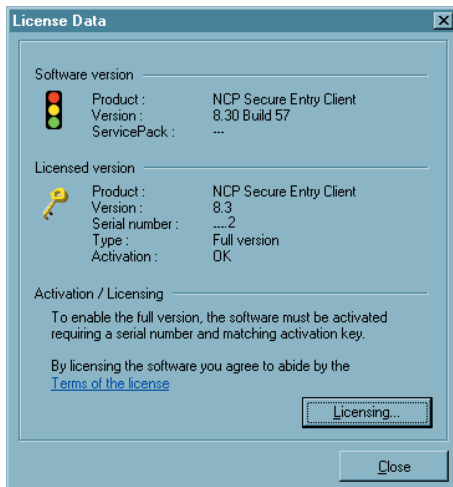

After concluding the activation process, you will see that you now have a correctly activated full version, in the window for the license data.

The number of the software version and the number of the licensed version can differ if the licensing is only valid for an older version.

If you have received a new license key from the Activation Server during the offline activation process (see above in the display of the activation code), then enter this license key for a license update, by clicking on the "Licensing" button.

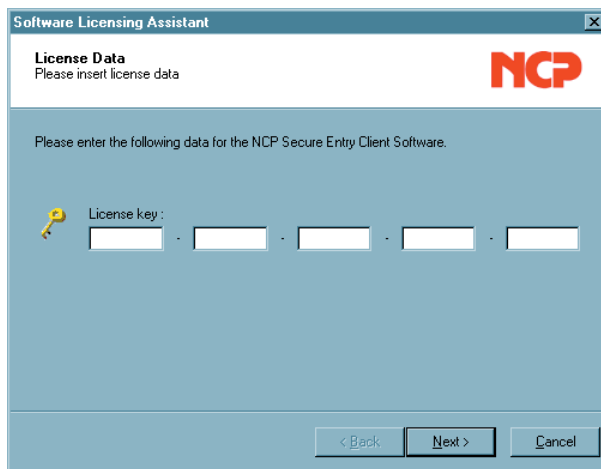

In next window of the Assistant, enter the new license key and click on "Next".

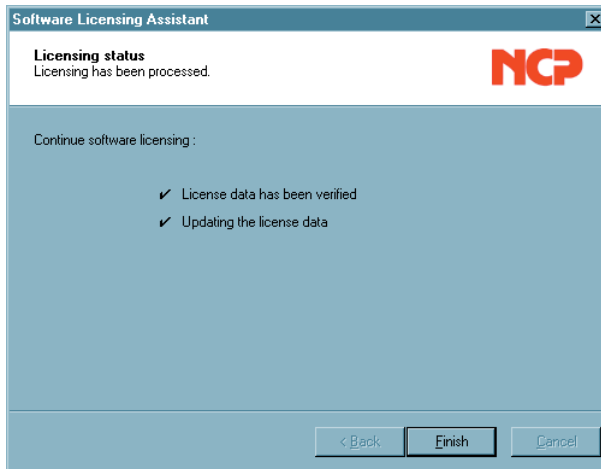

The license data will be verified and then transferred.

Click on "Finished" when the verification has been concluded.

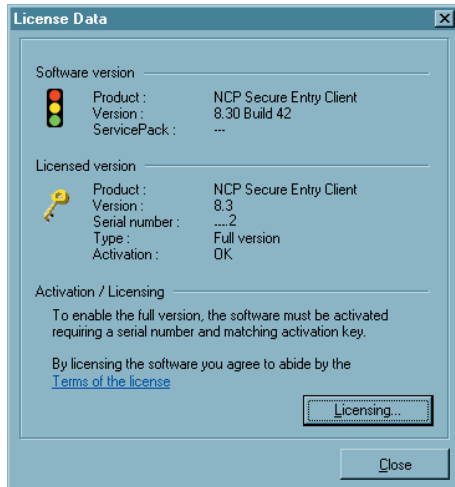

In the window with the license data you will see that the number of the software version and the number of the licensed version now agree.

## 4.7 Updates

Under the Menu option “Check for updates” in the Monitor menu under “Help” you can check whether a version of the software that is newer than the version you have installed is available at NCP. This is also possible if a test installation has been installed. If a newer version is available at NCP, then a software update is always possible. Information on the performance range of the latest software is always available on the web site:

<http://www.ncp.de/english/services/whatsnew/index.html>

The software update always costs money if the newer version is a major release, which is indicated by the change on the first decimal place. For example: If a version 8.26 is installed and the next software version has the number 8.3 then a software update from 8.26 to 8.3, as well as use of the new features, will cost money. The new license key was activated as described above under software activation. The new license key is generated by entering the serial number and the update key that can be purchased locally from the reseller, on the following web site:

<http://www.ncp.de/english/services/updkeys/index.html>

The software update always available free of charge if the newer version is a service release, this is indicated by the change of the second decimal place. For example: If a version 8.26 is installed and the next software version has the number 8.27 then a software update from 8.26 to 8.27, as well as use of the new features, will be free of charge. The new features can be used without activation with a new license key, as soon as the new software has been installed. A service release contains bug fixes, an extension of hardware support and compatibility extensions.

### 4.7.1 Software Updates

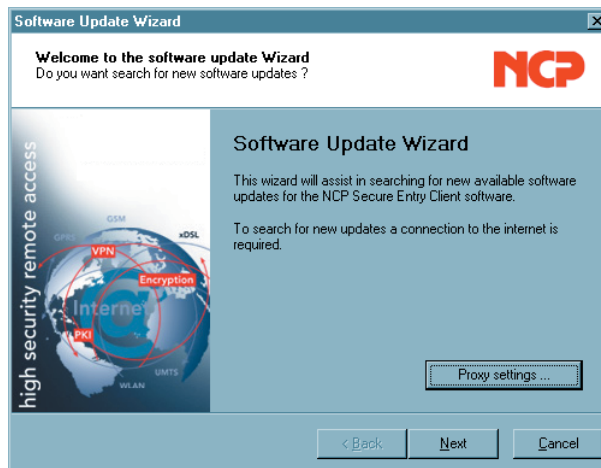

After you have selected the menu option “Check for updates” you will see the adjacent window. In order to check for new updates you will need an Internet connection. If the Entry Client will be used to set-up the Internet connection, then ensure that port 80 (for HTTP) is released if the firewall is active.

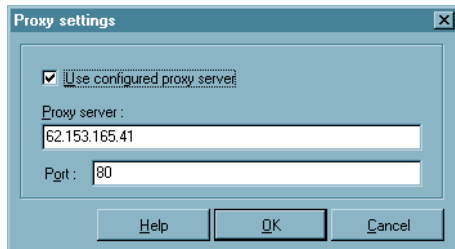

(If a proxy server will be configured in the operating system, then these settings can be transferred.)

If the proxy settings are correctly configured, then click on “OK”. The Assistant will now search for newly available software updates via the Internet connection.

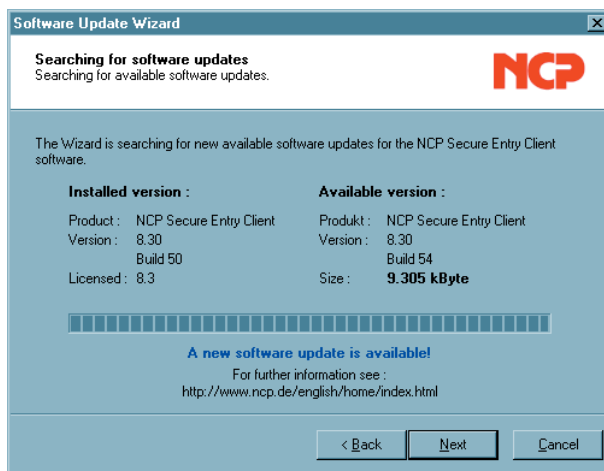

If a software update is available then it is displayed as shown in the next window.

(In this case the version is differentiated only via the build number.)

Click on “Next” if you want to use the more current version.

The new features are described under:

<http://www.ncp.de/english/services/whatsnew/index.html>

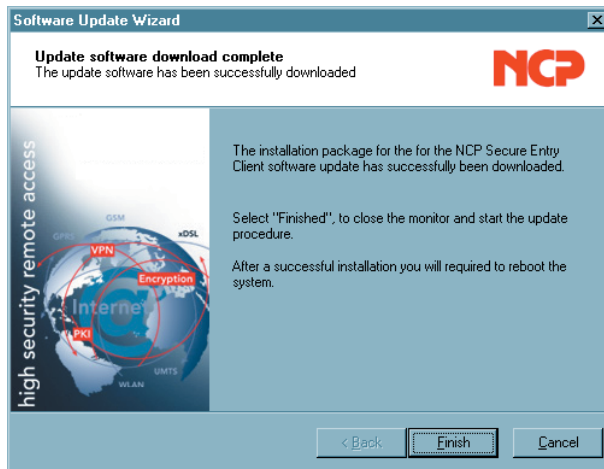

This downloads the installation package for the newest software.

Click on “Finished” to end the Monitor and start the installation of the software update.

After starting the Install shield Wizard select the installation language (as you would for the standard installation), and then answer the update query with “Yes”. Then the installation will be executed automatically. It is concluded when you reboot the computer.

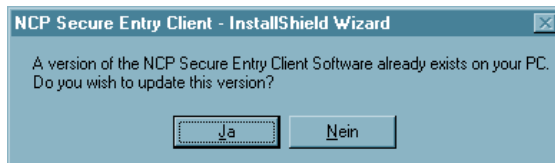

## 5. Configuration Parameters



With the IPSec client you can define and configure numerous individual profiles for corresponding destinations, in accordance with your communication requirements.

In this section all parameter descriptions are listed and they are arranged in the same sequential order as displayed in the monitor.



## 5.1 Profile Settings

Upon clicking “Profile Settings” in the monitor menu, the menu is opened with an overview of the defined profiles and the phonenumbers of the assigned destinations.

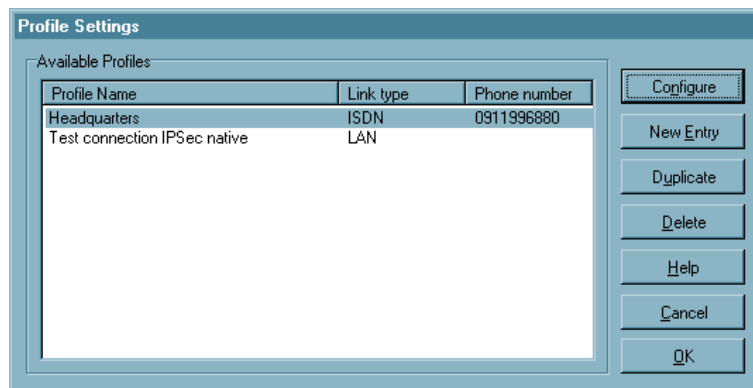

The buttons located to the right can be used to add, remove, copy and modify the entries of the profiles.

In order to define a new profile click on “Profile Settings” in the monitor menu under “Configuration”. Upon doing so the menu opens displaying any defined profiles. Click on “New Entry”. Enabling the “Configuration Assistant”, which assists in the creation of a new profile definition. All other parameters will be assigned default values.

To edit these default values, in order to fulfill the requirements of the profile, select the desired profile and then “Configure” to gain access to the individual parameters. (See → Profile Settings, Configure)

In order to duplicate a profile click on “Duplicate”

In order to delete a profile click on “Delete”.

## Parameterfolders:

Parameters which specify the connection via the profile to the destinations, are found in the configuration folders. The name of the profile appears in the titel bar (see →Profile Settings, Configure). Within the configuration folder the connection parameters pretaining to this profile can be configured.

- 1 *Basic Settings*
- 2 *Dial-Up Network*
- 3 *HTTP Logon*
- 4 *Modem*
- 5 *Line Management*
- 6 *IPSec General Settings*
- 7 *Advanced IPSec Settings*
- 8 *Identities*
- 9 *IP Address Assignment*
- 10 *Remote Networks*
- 11 *Certificate Check*
- 12 *Link Firewall*

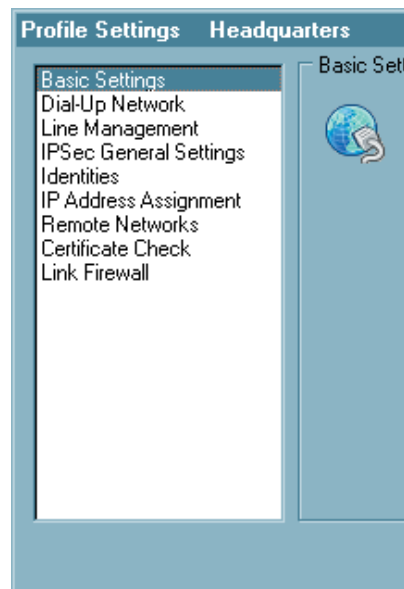

## 5.1.1 Basic Settings

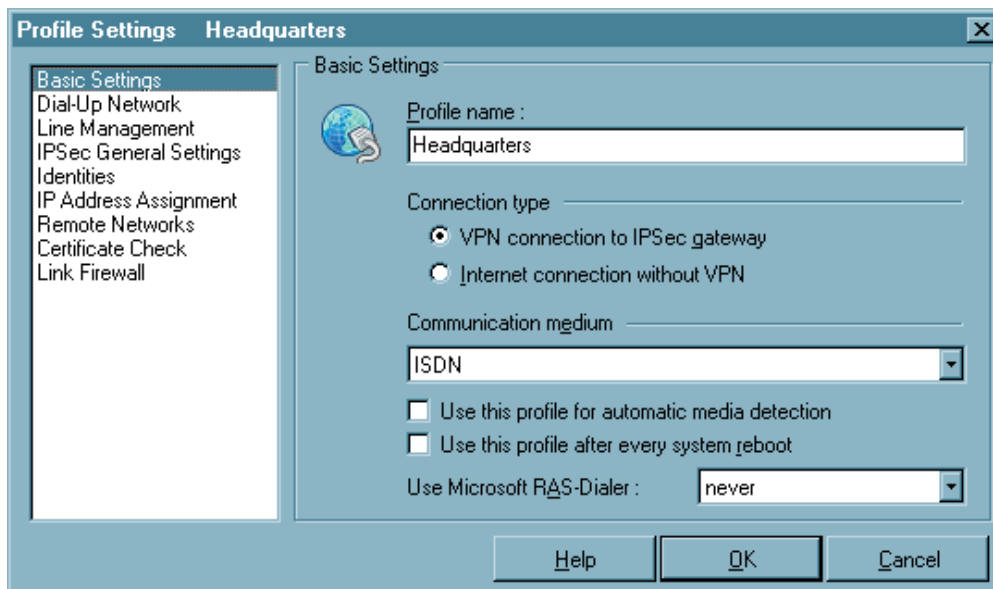

*In the folder “General” enter “Profile name”, the “Communication type” and the “Communication medium” you wish to use and is available to Windows.*

### **Parameters:**

- Profil name
- Connection type
- Communication medium
- Use this entry for automatic media detection
- Use Microsoft RAS-Dialer
- Use this phonebook entry after every system reboot

## ■ Profile name

When entering new profiles you should enter a unique name for each profile. The profile name may include any character or number as desired up to a maximum of 39 characters (including spaces).

## ■ Connection type

Alternatively there are two connection types available with the IPsec client:

### *VPN to IPsec correspondent*

In this case you dial into the corporate network (or into the gateway) with the IPsec client. A VPN tunnel is set up for this.

### *Internet connection without VPN*

In this case only use the IPsec client for dialing into the Internet. Here the Network Address Translation (IPNAT) continues to be used in background so that only those data packets are accepted that have been requested.

## ■ Communication medium

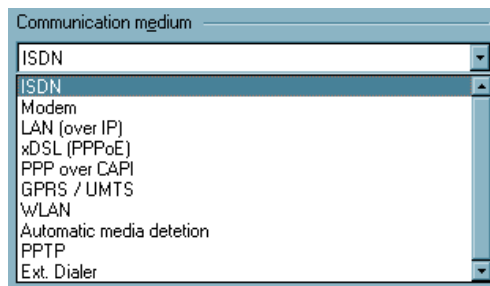

You can select the communication medium for each profile, provided that you have the required device installed on your PC and recognized by Windows.

### *ISDN*

Hardware: ISDN device;  
 Network: ISDN;  
 Remote destination: appropriate ISDN support;

### *Modem*

Hardware: Asynchronous modem (PCMCIA modem, GSM adapter) with COM Port support;  
 Network: PSTN (also GSM);  
 Remote destination: Modem or ISDN device with digital modem;

### ***LAN (over IP)***

Hardware: LAN adapter;  
Networks: Ethernet or Token Ring based LAN;

### ***xDSL (PPPoE)***

Hardware: Ethernet adapter;  
Networks: Broadband (e.g. ADSL);  
Remote destination: Access Router in the xDSL;

### ***xDSL (AVM – PPP over CAPI)***

If an AVM Fritz DSL card is to be used then this communication medium may be selected. AVM specific initialization strings may be entered in the field “Destination Phone Number” (“Dial-Up Network” group) for the connection. It is recommended to use the standard setting “xDSL (PPPoE)” with Windows operating systems as this provides direct communication over the network interfaces. No additional network card is necessary with the AVM Fritz! DSL card.

Networks: Broadband (e.g. ADSL);  
Remote Destination: Access Router in the xDSL

### ***GPRS / UMTS***

If a mobile (cellular) telephones is to be used (GRPS) then this communication medium may be selected. Note the description under “Installation Prerequisites” to “Analog modem”.

### ***PPTP***

Microsoft Point-to-Point Tunnel Protocol;  
Hardware: Ethernet-Adapter, xDSL Modem;  
Networka: xDSL;  
Remote destinations: Access Router in the xDSL;

## WLAN

Hardware: WLAN adapter;  
 Networks: WLAN;  
 Other sides: Access Point;



The WLAN connection type can only be used under Windows 2000/XP. Under Windows 98/NT the adapter for a wireless LAN (WLAN adapter) is handled precisely the same as a normal LAN adapter. In other words select “LAN (over IP)” as connection type for WLAN in this case as well. The WLAN card tool is used for this or the Windows tool for configuring the WLAN connection can be used.



Under Windows 2000/XP the WLAN adapter can be operated with the connection type “WLAN”. In the monitor menu the special “WLAN settings” menu option is displayed where the access data for the wireless network can be saved in a profile. If this “WLAN configuration” is activated, then the management tool of the WLAN card must be deactivated. (Alternatively the management tool of the WLAN card can also be used; in this case the WLAN configuration in the Monitor menu must be deactivated.)

If the connection type WLAN is set for the destination system in the phonebook, then under the graphic field of the Client Monitor an additional area is shown where field strength and the WLAN network are displayed (see -> WLAN Settings).

### Ext. Dialer

If this connection type is set, then a pre-configured EXE file (e.g. the iPass dialer) will start when you press the “Connect” button. This EXE file must first set-up the connection to the Internet and then trigger the set-up of the VPN connection to the client via “RWSCMD / connect”. In this case our dialer works in LAN mode.



This connection type will only work with manual connection setup.

With connection type “Ext. Dialer” in order not save yourself the trouble of entering the complete path for the dialer in the DAT file, alternatively the path can be read out of the registry. Two new INI entries have been created to detect the path for the dialer. Under “DialerExec” the EXE name of the dialer is all that must still be entered.

Example for Ipass:

The installation path of the Ipass dialer, “Software\Ipass\iPassConnectEngine” is located in the registry, under “InstallPath”. The EXE file must be entered manually:

```
DialerInstallPathKey    = Software\Ipass\iPassConnectEngine
DialerInstallPathValue = InstallPath
DialerExec              = IPassConnectGUI.exe
Caption                 = iPassConnect
```

## Automatic media detection

If different connection types are used in alternation, such as modem and ISDN, then manual selection of the destination system with the respectively available connection medium is not necessary, if a destination system has been configured for “Automatic media detection”, and in each case a destination system with the alternatively available connection types, such as modem and ISDN has been selected.

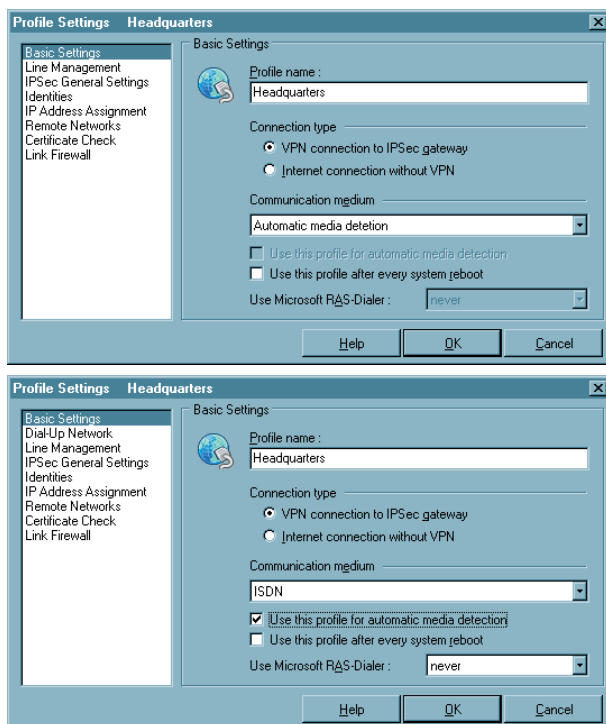

In this regard ensure that the destination system with automatic media detection is configured with all parameters necessary for the connection to the VPN Gateway (particularly the IP address of the VPN gateway), on the other hand the destination systems with the alternative connection types must be configured in such a manner that each desired connection type (possibly the modem parameters as well) is set and the function “Entry for automatic media detection” is activated.

In addition for the respective connection medium the input data to the ISP must be set in the “Network dial-in parameter field.”

For connection setup the Client automatically detects which connection types are currently available and selects the fastest of these, and if there are multiple alternative transmission paths it automatically selects the fastest. The connection type priority is specified in the following sequence in a search routine: 1. LAN, 2. WLAN, 3. DSL, 4. UMTS/GPRS, 5. ISDN, 6. MODEM. The incoming data for the connection for the ISP are transferred from the phonebook entries that have been configured for automatic media detection.

### ■ Use this profile after every system reboot



Normally after a restart the Client Monitor opens with the last profile used. If this function is activated, then the profile referred to here is loaded after a system re-start, regardless of which profile was last used.

In order to setup a connection, this profile can also be selected manually. assumed that the VPN parameters have been configured correctly.

- **Use this phonebook entry after every system reboot**

Normally after a restart the Client Monitor opens with the last profile used. If this function is activated, then the profile referred to here is loaded after a system re-start, regardless of which profile was last used.

- **Use Microsoft RAS-Dialer**

Microsoft's RAS Dial-Up Networking can be used for dialing in to an ISP. This is necessary when the access point requires a dial-up script. The RAS Dial-Up Networking supports this script. The option "Use Microsoft RAS Dialer" is located in the Client's Phonebook under Destination. The RAS Script file including its path and name can be entered in the parameter folder "Dial-Up Network" (see -> RAS Script file).

With the "Never" setting the NCP Dialer is used exclusively to dial-in. If the data communications dialer will be used "only for script dial-in", then select this option. For a dial-in point that does not require a script, the system automatically switches to the NCP Dialer. If the data communications dialer will always be used, then the appropriate setting must be made.



## 5.1.2 Dial-Up Network

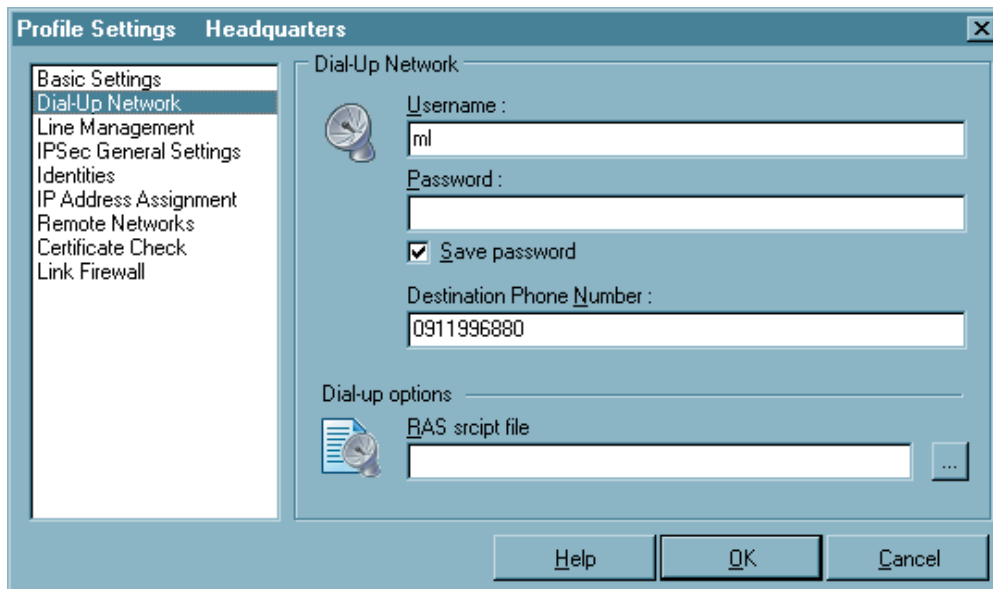

*This folder contains the parameters Username and Password, which are needed to properly identify you when accessing the destination. From a technical standpoint these two items are included as part of the PPP negotiation to the ISP (Internet Service Provider). If the Communication media “LAN over IP” has been selected, then this folder will not appear since these parameters are not relevant for LAN operation.*

### **Parameters:**

- Username
- Password
- Save password
- Destination phone number
- Alternate destination phone numbers
- RAS script file

## ■ Username

This parameter is used to identify yourself to the remote Network Access System (NAS) when establishing a connection to your destination, or alternatively to your Internet Service Provider (ISP) if you are communicating across the Internet. The username may consist of up to 254 characters. Normally the username will be assigned to you by your destination (e.g. your company Headquarters, User Help Desk, Internet Service Provider, etc.), because it must be supported and accepted by the NAS, Radius or LDAP server for authentication purposes.

## ■ Password

This parameter is used for identifying yourself to your Internet Service Provider (ISP) if the Internet is used. The password can include up to 128 characters. Normally the password will be assigned to you by your destination (e.g. your company Headquarters, User Help Desk, Internet Service Provider, etc.), because it must be supported and accepted by the NAS, RADIUS or LDAP Server for authentication purposes.

Upon entering your password all characters will be displayed as an asterisk (\*) in order to keep them from being detected by someone else. Therefore it is necessary to be very careful that you enter your password exactly the way in which it was assigned to you (also with regards to the use of upper case and lower case characters).



If the user chooses not to enter and save the password he will be prompted to manually enter it with every connection attempt.

## ■ Save password

This parameter should be activated when it is desired that the Password (if entered) is to be stored. Otherwise it will be removed from memory when (re)booting the PC or changing the profile. Default is the activated function.



Important: For security purposes you must be aware that should some unauthorized person use your PC, they will be able to use your password. Therefore caution should be used when your PC is left unattended.

## ■ Destination phone number

You must define a phone number for those destinations using ISDN/PSTN/GSM otherwise the Client will not be able to dial up and establish a connection to the destination or ISP. The phone number must be entered exactly in the same manner as if you were dialing the number from a telephone. You must enter any required prefixes, country codes, area codes, extensions, etc. etc.

In order to acquire an outside line when communicating via a PBX it is necessary to define an “Outside Line Prefix” (see →Outside Line Prefix) in the monitor menu “Configuration”.

*Example: Making a connection from Germany to UK:*

00 (gets you an international line when dialing from Germany)

44 (this is the country code for United Kingdom)

171 (prefix for London)

1234567 (the number you want to reach)

The following number will be used by the Client for dialing purposes and it will be displayed in the Phonebook as follows: 00441711234567.

The destination phonenumber may include up to 30 characters.

## ■ Alternate destination phone numbers

It could be that the destination you want to communicate with uses a Network Access System (NAS) that is equipped with multiple phone numbers. If this is the case, then it may be useful to enter more than one phone number for the destination if for example the primary Destination Phone Number is occupied. The alternate destination phone number(s) can be entered following the primary destination phone number and separated by a colon (:).

A maximum of 30 digits can be entered in the Destination phone number field. The IP-Sec client supports a maximum of 8 alternate phone numbers.

Example: 00441711234567:00441719876543

The first number is the primary Destination Phone Number and will always be dialed first. The second number is the Alternate Destination phone number and will be dialed when a connection to the primary number is not possible.

Important: This will only work if the protocol settings associated with alternate Destination phone number are the same as the primary Destination phone number

## ■ RAS script file

If Microsoft’s RAS Dial-Up networking is to be used, the RAS script file including its path and name must be entered.

(See →Basic Settings, Use Micosoft RAS-Dialer)

### 5.1.3 HTTP Logon

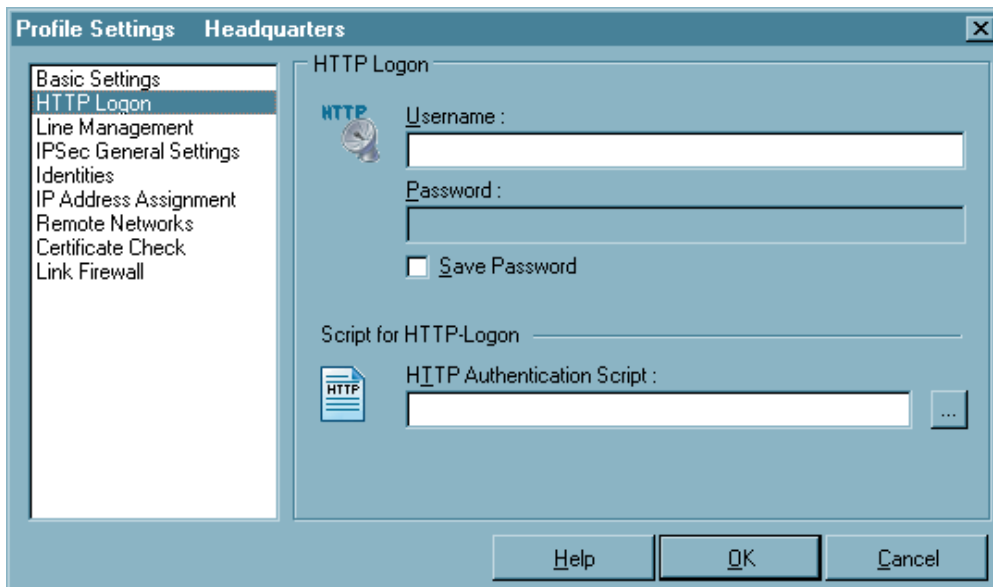

The automatic HTTP logon can be executed automatically with the settings in this parameter field. Centrally created logon scripts and the stored logon data can be transferred from the access point hotspot without opening a browser window.



Please note that there are charges associated with the connection via a HotSpot operator. You must agree to the terms and conditions of the HotSpot operator in order to set up the connection.

#### Parameters:

- User name | HTTP Logon
- Password | HTTP Logon
- Save Password | HTTP Logon
- HTTP Authentication Script | HTTP Logon

The logon at the HotSpot is automated with these data. This is executed as follows; for a connection setup to the Access Point an HTTP redirect to the Client with a website for logon is executed from the Access Point. Instead of a browser start for HTTP authentication, the authentication occurs automatically in background, with the entries made here.

For script driven logon you can use a script from the installation directory  
`<install>\scripts\samples`  
and you can modify it for other HotSpots



For the WLAN connection type the authentication data for the HotSpot are transferred from the WLAN settings.

- **Username | HTTP Logon**

This is the user name that you have obtained from your HotSpot operator.

- **Password | HTTP Logon**

This is the password that you have obtained from your HotSpot operator. The password is concealed with asterisks (\*) when entered.

- **Save Password | HTTP Logon**

After the password has been entered it can be saved

- **HTTP Authentication Script | HTTP Logon**

Click on the Browse button [...] to select the saved logon script.

## 5.1.4 Modem

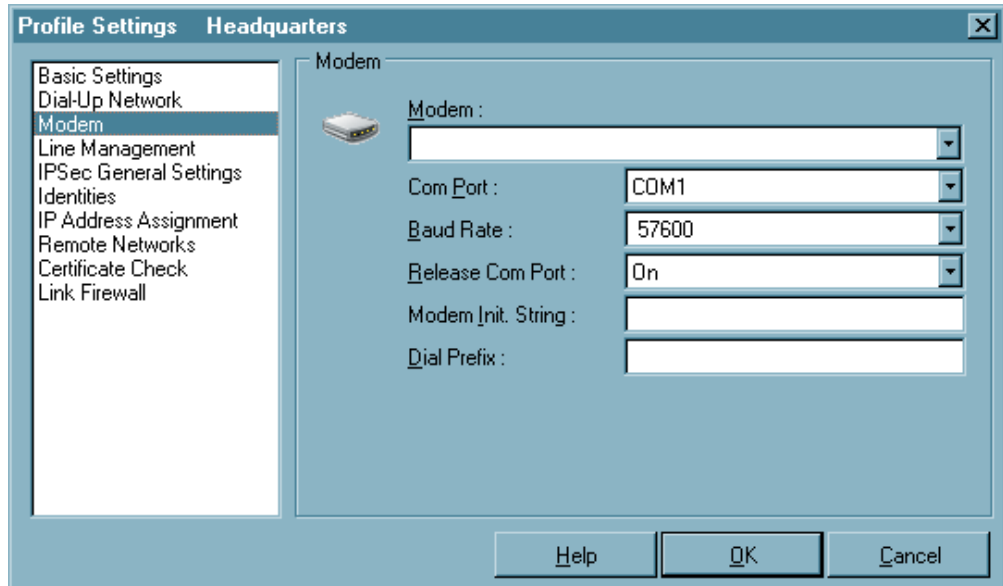

*This parameter field is only displayed if your selected communication medium is "Modem". All necessary parameters for this link type are listed here.*

### **Parameters:**

- Modem
- COM Port
- Baud Rate
- Release COM Port
- Modem Init. String
- Dial Prefix
- APN
- SIM PIN

## ■ Modem

This field will view the modem(s) installed on your PC. Select the required modem.

Selecting a Modem causes the corresponding COM Port and Modem Init. String for this Modem to be automatically entered in the appropriate Phonebook Link Definition parameter fields.

All other parameters for this communication media can be configured in the control panel of your PC.



Note: We recommend that you install your Modem prior to installing and configuring the Secure Client. In this case the Secure Client will automatically use the driver and values installed with the Modem.

## ■ COM Port

In this field you can define the COM Port to be used by your Modem. Normally when you install a Modem under Windows the COM Port will be defined during the installation of the Modem. If you then select Modem under the Link Definition field, the COM Port already assigned to the Modem will be automatically enter in the COM Port field.



Note: We recommend that you first select the appropriate modem in the field “Modem”. Thereafter the Secure Client will automatically import and use the pre-defined COM Port.

## ■ Baud Rate

Baud Rate refers to the transmission rate between the PC’s Com Port and the Modem. If for example your Modem is able to transmit data at 14.4 Kbits, then the Baud Rate should be set to 19200 (factory default setting).

The following rates may be selected:

1200, 2400, 4800, 9600, 19200, 38400, 57600 und 115200

## ■ Release Com Port

If you are using an analog modem for communications in conjunction with the IPsec client, it may be desirable upon conclusion of each communications session to release the Com Port for other communication applications (e.g. Fax, Answering Machine). As long as this parameter is set to “OFF” (factory default setting), the Com Port will be assigned exclusively to the Secure Client, and no other application will be able to use it.

## ■ Modem Init. String

AT commands can be required, depending on the mobile (cellular) phone or modem and the link mode. For these commands, refer to the respective user manual or obtain the information from your telco or provider. Complete each command with <cr> (Carriage Return).

## ■ Dial Prefix

This field is optional. Normally it will not be necessary to enter anything in this field, provided that your modem has been properly installed and is available to the client as a standard communications driver. However, if it is desirable to enter a “Dial Prefix”, refer to your Modem manual for more detailed information.

Following are some examples of Dial Prefixes:

ATDT  
ATDP  
ATDI  
ATDX

## ■ APN

The APN (Access Point Name) is required for the GPRS and UMTS dial-in. You obtain this name from your provider. The APN is used particularly for administrative purposes.

## ■ SIM PIN

If you use an SIM plug-in card for GPRS (UMTS also), then enter the PIN for this card here. If you use a mobile phone, then this PIN must be entered on the mobile phone.

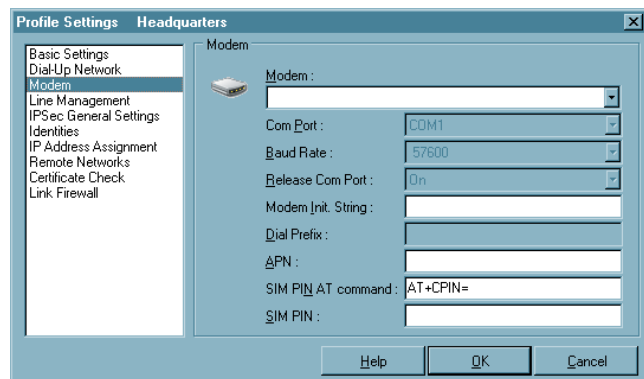



## 5.1.5 Line Management

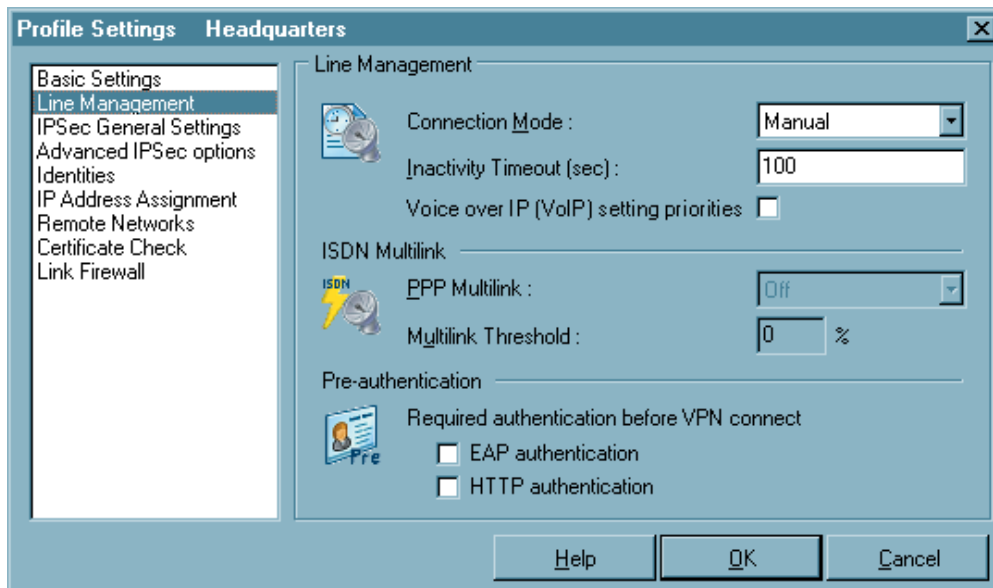

In the “Line Management” you can define the Connection Mode as well as Timeout values used for automatically disconnecting the link.

If the client is using the communication medium ISDN you can activate channel bundling in this folder. In order for channel bundling to work requires that your PC be equipped with a communications device that supports multiple ISDN B-Channels. It is also necessary that the Network Access System that you are communicating with supports the same number of channels.

The required authentication before VPN connect is assigned by the network of the hotspot operator.

### Parameters:

- Connection Mode
- Inactivity Timeout
- Voice over IP (VoIP) setting priorities
- PPP Multilink
- Multilink Threshold
- EAP Authentication
- HTTP Authentication

## ■ Connection Mode

You can define how the client builds a link via the profile to the destination. There are three Modes to select from:

- |           |   |  |
|-----------|---|--|
| automatic | = | (default) Means that the Secure Client will automatically activate a connection in accordance with your application program requirements to the profile setting. A disconnect also occurs automatically, provided that the Inactivity Timeout parameter is set to any value other than zero.   |
| manual    | = | Means that you must manually activate a connection. Disconnect will be activated by the Inactivity Timeout provided that this parameter has been set to any value other than zero (0).   |
| variable  | = | When this mode is selected, the connection must be established “manually”. Subsequently, the mode adapts according to the manner in which the connection was terminated: <ul style="list-style-type: none"><li>– If the connection was terminated as a result of a timeout, then the following connection will be automatically initiated as required.</li><li>– If the connection was terminated manually, then the following connection must also be established manually.</li></ul> |



**Important:** When setting the Connection Mode to “Manual” you should also set the Inactivity Timeout parameter to any value other than zero (0) in order for an automatic disconnect to be made. Otherwise you may incur unnecessary communication costs if a Disconnect is not executed.

## ■ Inactivity Timeout

This parameter is for setting the time delay to be used following the last transmission of data before automatically executing disconnect. Time is expressed in seconds. Possible settings are from 1 to 65356 seconds. The default value is “100”..

If your communications connection (regardless of link type) receives a Charge/Unit impulse from the network provider, this will be used by the Secure Client Timeout feature for achieving an optimal disconnect time with regard to the value set in the Inactivity Timeout. This optimized timeout feature will further help to reduce communication costs.



**Note:** In order for the Inactivity Timeout to be activated it is necessary to enter any value from 1 to 65356. The value “0” (zero) means that no automatic timeout (disconnect) will be executed. When the Inactivity Timeout is set to ”0” (zero) you must manually execute Disconnect.



**Important:** The Inactivity Timer only begins counting down after the last data transmission and after any communications handshaking has stopped.

## ■ Voice over IP (VoIP) setting priorities

If this Client is used for communication with Voice over IP, then this function should be activated in order to send and receive the voice data without delay and without distortion.

## ■ PPP Multilink

When using PPP Multilink the Secure Client can bundle up to 8 ISDN B-Channels, therefore in order to take advantage of this your PC must be equipped with the necessary number of ISDN BRI (Basic Rate Interface) ports.

In order for Multilink to work requires that your PC be equipped with an ISDN device that supports multiple ISDN B-Channels. It is also necessary that the Network Access System (NAS) that you are communicating with support Multilink operation. When using PPP Multilink additional costs will be incurred for each B-Channel used.

This parameter defines how additional links will be added if requested. There are 3 possible settings:

off	(default setting)
Tx	(links are added according to the bit rate demanded by the transmitter)
Rx	(links are added according to the bit rate demanded by the receiver)
TxRx	(links are added according to the bit rate demanded by both transmitter and receiver.)

## ■ Multilink Threshold

This parameter tells the client the bit rate (as a percent of the current bit rate) at which a new link (B-Channel) is to be added. Possible settings are from 1 to 100. The default setting is "20". The Threshold setting is common to both transmitter and receiver.

In order for this value to be activated it is necessary to have Tx, Rx or TxRx under PPP Multilink selected.

Important: In order for PPP Multilink to work it must be supported by the destination's Network Access System.+

## ■ EAP authentication

If the Client must authenticate itself at the Access Point (HotSpot) with EAP (Extensible Authentication Protocol), then this function must be activated. It means that for this destination system the EAP configuration in the Monitor menu under “EAP options” will be used.



Please note that the EAP configuration in the monitor menu is valid for all destination systems and must be switched active if this link-specific setting will be effective.

EAP is used if an Access Point is used for the wireless LAN that is 802.1x capable, and it demands a corresponding authentication. This can prevent unauthorized users from plugging into the LAN via the hardware interface.



After configuration of the EAP a status display must appear in the graphic field of the Monitor. If this is not the case then the EAP configuration must be switched active in the Monitor menu. Double click on the EAP icon to reset the EAP. Then the EAP is renegotiated.

## ■ HTTP authentication

This function must be activated for automatic HTTP authentication at the access point (HotSpot).

For this an additional parameter field “HTTP Logon” must be switched on in the phonebook, where the authentication data can be entered thereafter (see -> Next parameter field).



The HTTP logon is not switched on in the phonebook for a link with the connection type WLAN! Instead, activation of this function causes the authentication data from the WLAN settings in the Monitor menu to be used for this destination system.

## 5.1.6 IPSec General Settings

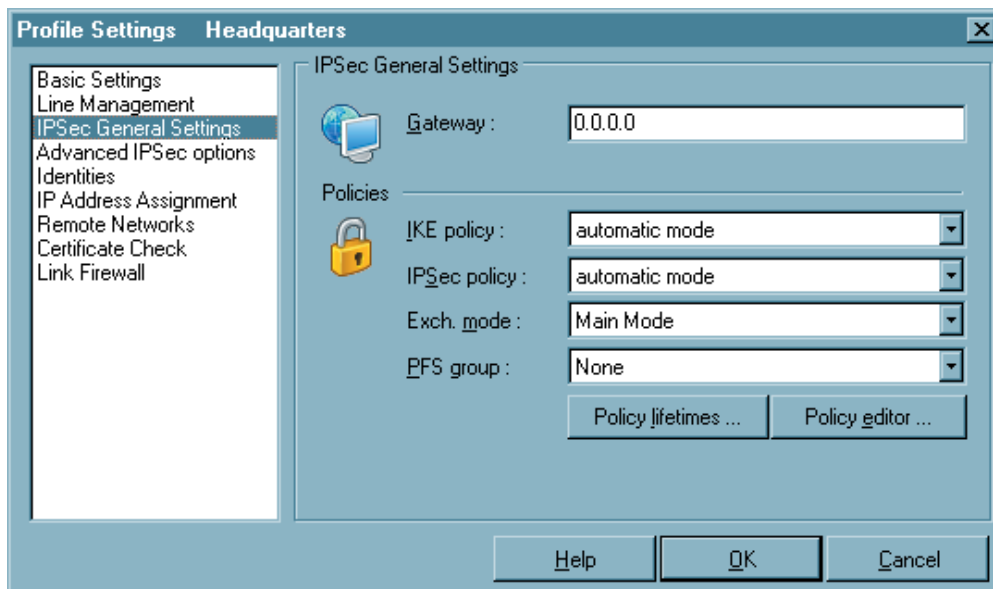

*In this parameter folder you enter the IP address of the gateway. Furthermore you determine the policies to be used for the IPSec connection in the negotiation of phase 1 and 2. Using the automatic mode, the client accepts the policies assigned by the gateway. Should the client use its own policies as the initiator of the connection, you have to configure them with the policy editor. The advanced options could be used according to the requirements of the gateway.*

### Parameters:

- |   |                                     |
|---|-------------------------------------|
| <input type="checkbox"/> Gateway          | <input type="checkbox"/> Exch. mode |
| <input type="checkbox"/> IKE Policy       | <input type="checkbox"/> PFS group  |
| <input type="checkbox"/> IPSec Policy     |                                     |
| <input type="checkbox"/> Policy lifetimes |                                     |
| <input type="checkbox"/> Policy editor    |                                     |

## ■ Gateway

This is the IP address of the IPSec gateway. You receive the address from your administrator as an IP number, if the gateway has a permanent official IP address – or as a string “hostname” that is mapped to a dynamic IP address from the Internet Service Provider.

**IP address:** The address is 32 bits long and consists of four numbers separated by periods.

**Name (String):** Enter the name which you have received from your administrator. This is the DNS Name of this gateway which is stored by the DynDNS service provider.

A second gateway can be entered in the same syntax after a comma.

## ■ IKE Policy

The IKE policy is selected from the list box. All IKE policies that you set up with the policy editor are listed under IKE policy. The policies appear in the box with the name that you specified in the configuration.

You will find two pre-configured policies in the policy editor under IKE policy as “Pre-shared Key” and “RSA Signature”. Contents and name of these policies can be changed at any time, i.e. new policies can be added. Every policy lists at least one proposal for authentication and encryption algorithms (see →IKE Policy (editing)). This means that a policy consists of different proposals. There are functional differences between these two IKE policies by using a static key or an RSA signature (see →Examples and Explanations, IPSec, IKE Modes).



The same policies with their affiliated proposals should be valid for all users. This means that on the client side, as well as on the server side, the same proposals for the policies should be available.

**Automatic mode:** In this case it is not necessary to configure the IKE policy in the “IPSec Configuration”. It will be assigned by the remote site.

**Pre-shared Key:** This preconfigured policy can be used without PKI support. The same “Static Key” is used on both sides (see →Pre-shared key, Shared secret in the parameter folder “Identity”).

**RSA Signature:** This preconfigured policy can only be set with PKI support. Implementation of the RSA signature as additional strong authentication only makes sense when using a Smart Card or a soft certificate.

## ■ IPsec Policy

The IPsec policy is selected from the List box. All IPsec policies that you set up with the policy editor are listed under IPsec policy. The policies appear in the box with the name that you specified in the configuration.

Two IPsec policies differ according to the IPsec security protocol AH (Authentication Header) or ESP (Encapsulating Security payload). Because the IPsec mode with AH security is totally unsuitable for flexible remote access, only an IPsec policy with ESP protocol, "ESP - 3DES - MD5", is preconfigured and comes standard with the software (see →Examples and Explanations, IPsec, AH and ESP).

Every policy lists at least one proposal for authentication and encryption algorithms (see →IPsec Policy (editing)). This means that a policy consists of different proposals.



The same policies with their affiliated proposals should be valid for all users. This means that on the client side, as well as on the server side, the same proposals for the policies should be available.

Automatic mode: In this case it is not necessary to configure the IPsec policy with the policy editor. It will be assigned by the destination.

ESP - 3DES - MD5 (or other policy name): When selecting the name of the pre-configured IPsec policy the same policies with their affiliated proposals should be valid for all users. This means that on the client side, as well as on the server side, the same proposals for the policies should be available.

## ■ Exch. mode

The Exchange Mode determines how the "Internet Key Exchange" should proceed. Two different modes are available; Main Mode also referred to as Identity Protection Mode and the Aggressive Mode. These modes are differentiated by the number of messages and by their encryption.

Main Mode: in Main Mode (standard setting) six messages are sent over the Control Channel and the last two messages are encrypted. The last two messages contain the username, the signature or a hash value. This is why it is also known as Identity Protection Mode.

Aggressive Mode: in Aggressive Mode only three messages are sent over the Control Channel and nothing is encrypted.

## ■ PFS group

With the selection of one of the offered Diffie Hellman groups it is determined whether a complete Diffie Hellman, (DH Group), key exchange (PFS, Perfect Forward Secrecy) should occur in Phase 2 in addition to the SA negotiation. The Standard is "none".

## Policy lifetimes

The lifetime of the policies defined here are applicable to all the policies.

### ■ Duration

The number of Kbytes or the size of the time interval can be adjusted.

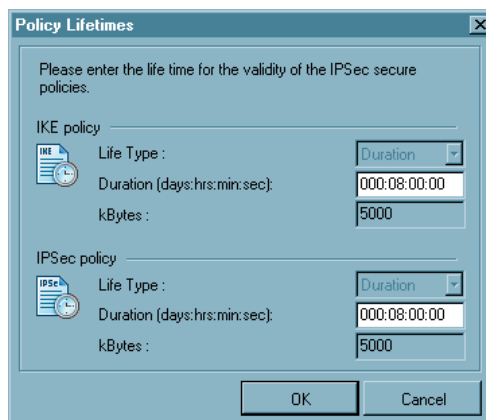

## Policy editor

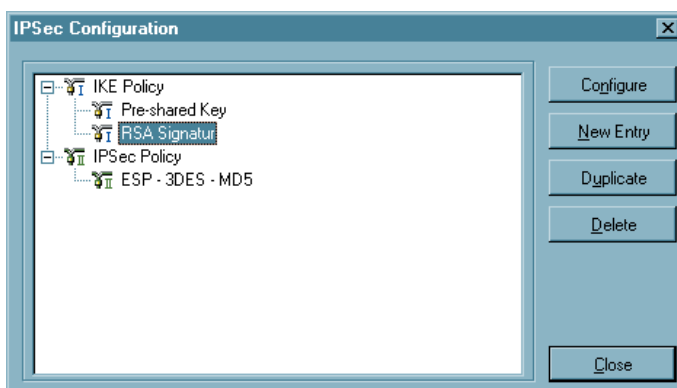

This menu item is clicked for configuring policies and, if necessary, a static Secure Policy Database. A configuration window will open displaying the branch with the policies and the Secure Policy Database as well as buttons for operation in the right-hand part of the configuration window.

Use the mouse to select the policy whose values are to be modified. The buttons will then be active. The (default) values of the policies can be edited, i.e. the parameters can be set or modified according to the requirements for the link to the defined destination

### Configure

If you want to change any Policy or SPD data and parameters, start by selecting the appropriate name and then click on the “Configure” button. Upon doing so a folder opens and displays the IPSec parameters.

### New Entry

In order to define a new Policy or SPD, select one of the Policies or the SPD and click on “New Entry”. The new Policy/SPD is entered. All parameters are assigned a default value except the Name.



### Duplicate

You may want to use an existing Policy or SPD for the basis of a new one, however with some slight modifications. In order to do so first select the Policy or SPD to be duplicated and then click on the “Duplicate” button. Upon doing so a parameter folder will open. You must now enter a new name for this group and then click on “OK”. A new Policy or SPD is now created with parameters identical to those that were duplicated except for the Name.

### Delete

If you want to delete a Policy or SPD from the IPSec configuration tree select the appropriate group and then click on the “Delete” button. Upon executing “Delete” the Policy or SPD will be permanently deleted.

### Close

When you click on “Close” the IPSec folder closes and returns to the Monitor.

## IKE Policy (edit)

Authentication	Encryption	Hash	DH Group
Preshared Key	AES 128 Bit	SHA	DH-Group 2 (1024 Bit)

The parameters in this field relate to phase 1 of the Internet Key Exchange (IKE) with which the control channel for the SA negotiation was established. You determine the IKE mode (Exchange Mode), main mode or aggressive mode, in the Phonebook under “IPSec General Settings”.

The IKE policies that you configure here will be listed for the policy selection.

Contents and name of these policies can be changed at any time, i.e. new policies can be added. Every policy lists at least one proposal for authentication and encryption algorithms. This means that any policy can consist of several proposals.

The same policies with their affiliated proposals should be valid for all users. This means that on the client side, as well as on the server side, the same proposals for the policies should be available.

You can extend the list of proposals or delete a proposal from the proposal list by using the buttons “Add” and “Remove”.

### ■ Policy Name | IKE Policy

Give this policy a name over which later an SPD can be allocated.

### ■ Authentication | IKE Policy

Both sides must have been successfully authenticated in order to establish a control channel for phase 1 (IKE Security Association).

The authentication mode is limited to the use of pre-shared keys. This means for mutual authentication a static key is used. You define this key in the parameter folder “Identity”.

### ■ Encryption | IKE Policy

Symmetrical encryption of messages 5 and 6 in the control channel occurs according to one of the optional encryption algorithms if Main Mode (“Identity Protection Mode”) is used. Choices are DES, 3DES, Blowfish, AES 128, AES 192, and AES 256.

### ■ Hash | IKE Policy

This is mode that determines how the hash value over the ID is formed, or in other words this determines which hash algorithm is used in the IKE negotiation. Choices are: MD5 (Message Digest, version 5), SHA (Secure Hash Algorithm), SHA 256, SHA 384 and SHA 512-bit.

### ■ DH Group | IKE Policy

The selection of one of the offered Diffie Hellman groups determines the level of security for the key exchange in the control channel. Later a symmetrical key will be generated according to this selection. The higher the DH group the more secure the key exchange will be.

## IPSec Policy (edit)

The screenshot shows the 'IPSec Policy' configuration window. The 'Name' field is filled with 'ESP - 3DES - MD5'. A table below it lists the policy details:

Protocol	Transform	None
ESP	AES 128 Bit	MD5

Below the table, the 'Protocol' dropdown is set to 'ESP', 'Transform' is set to 'AES 128 Bit', and 'Authentication' is set to 'MD5'. There are 'Add' and 'Remove' buttons next to these dropdowns. At the bottom of the window are 'Help', 'OK', and 'Cancel' buttons.

The IPSec policies (Phase 2 parameters) that you configure here will be listed for the policy selection.

The same policies with their affiliated proposals should be valid for all users. This means that on the client side, as well as on the server side, the same proposals for the policies should be available.

You can extend the list of proposals or delete a proposal from the Proposal List by using the buttons "Add" and "Remove".

- **Policy Name | IPSec Policy**

Give this policy a name over which an SPD can later be allocated.

- **Protocol | IPSec Policy**

The fixed default value is ESP.

- **Transformation (ESP) | IPSec Policy**

One can specify which encryption algorithms (DES, Triple DES, Blowfish, AES 128, AES 192, and AES 256) are to be used within the ESP (Encrypted Security Payload). Multiple IPSec proposals with different security combinations can be defined.

- **Transformation (Comp) | IPSec Policy**

IPSec compression. The data transmission with IPSec can also be compressed as in transfer without IPSec. This enables a maximum threefold increase in throughput. After selecting the "Comp" (compression) protocol you can select between LZS and deflate compression.

- **Authentication | IPSec Policy**

The authentication mode can be specifically set here for the security protocol ESP. Choices are: MD5, SHA, SHA 256, SHA 384 and SHA 512-bit

## 5.1.7 Advanced IPsec Options

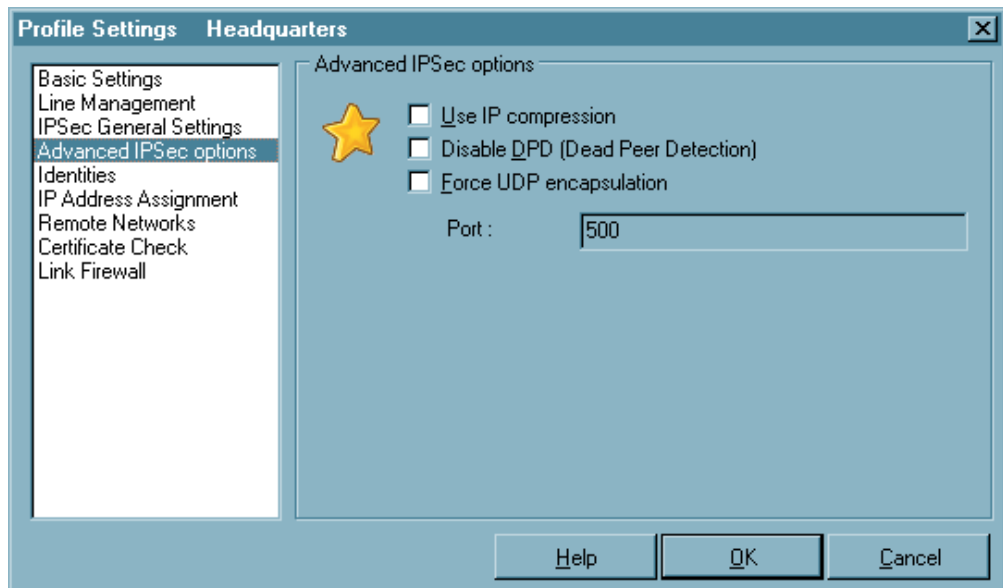

*In this field you can enter further IPsec settings.*

### **Parameters:**

- Use IP compression (LZS)
- Disable DPD (Dead Peer Detection)
- Force UDP Encapsulation

### ■ **Use IP compression (LZS)**

The data can be compressed in order to increase transmission rates. By enabling compression the throughput can be increased to up 3 times that the regular transmissions without compression.

### ■ **Disable DPD (Dead Peer Detection)**

DPD (Dead Peer Detection) and NAT-T (NAT Traversal) are automatically executed in the background if supported by the destination gateway. The IPSec client uses DPD to check, in regular intervals, whether the other side is still active. If the other side is inactive, then an automatic connection-disconnect occurs.

With this function you can disable DPD.

### ■ **Force UDP Encapsulation (Port 4500)**

With UDP encapsulation only port 4500 should be released on the external firewall, (this is different than the situation with NAT Traversal or UDP 500 with ESP). The NCP Gateway detects UDP encapsulation automatically.

If UDP encapsulation is used then the port can be freely selected. Standard for IPSec with UPD is port 4500, for IPSec without UDP port 500.

## 5.1.8 Identities

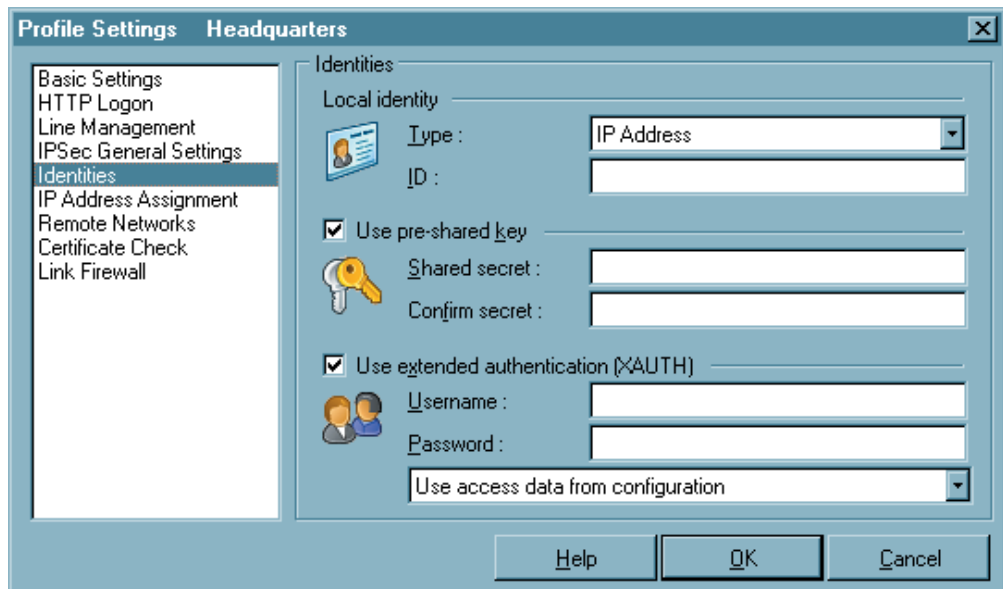

According to the security mode setting IPSec a more detailed parameter setting can take place.

### Parameters:

- Type | Identity
- ID | Identity
- Use pre-shared key
- Use extended authentication (XAUTH)
- Username | Identity
- Password | Identity
- Use access data from configuration

## ■ Type | Identity

For IPSec there is a differentiation of incoming and outgoing connections. The value that the initiator selected as ID for outgoing connection must also be selected by the recipient as the ID for incoming connection.

The following ID Types are available:

- IP Address
- Fully Qualified Domain Name
- Fully Qualified Username  
(entspricht der E-Mail-Adresse des Benutzers)
- IP Subnet Address
- ASN1 Distinguished Name
- ASN1 Group Name
- Free String used to identify Groups

## ■ ID | Identity

For IPSec there is a differentiation of incoming and outgoing connections. The value that the initiator selected as ID for outgoing connection must also be selected by the recipient as the ID for incoming connection.

According to the selected ID type the character string i.e. the address range (with minus “-”) must be entered in this field.

## ■ Use pre-shared key

The pre-shared key is a string of the max. length of 255 characters. Any (alpha)numeric characters can be used. If the other side expects a pre-shared key during the IKE negotiation, then this key must be entered in the field “Shared secret”.

Please confirm the shared secret in the field below. The same pre-shared (static) key must be used at both end points of the communication.

## ■ Use extended authentication (XAUTH)

The authentication for “IPSec Tunneling” can be dealt with utilizing extended authentication (XAUTH protocol, Draft 6). If “XAUTH” is to be used, and supported by the gateway, enable “Use extended authentication (XAUTH)”. In addition to pre-shared key, username and password can be defined:

Username = Username of the IPSec user

Password = Password of the IPSec user

### ■ Username | Identity

Contact your System Administrator for your “Username”. The name can be up to 256 characters long.



Note: This parameter pertains only to accessing the gateway at the remote site.

### ■ Password | Identity

Contact your System Administrator for your “Password” for XAUTH. The password can be up to 256 characters long.



Note: This parameter pertains only to accessing the gateway at the remote site.

### ■ Use access data from configuration

You can select one of the following methods for authenticating the VPN tunnel against the gateway:

Use access data from configuration:

The VPN tunnel will be authenticated based on the User ID and Password entered in the respective fields above.

Use access data from certificate field “e-mail”:

The VPN tunnel will be authenticated based on the contents of E-Mail field of the selected certificate.

Use access data from certificate field “cn”:

The VPN tunnel will be authenticated based on the contents of “Customer” field of the selected certificate.

Use access data from certificate field “serial no.”:

The VPN tunnel will be authenticated based on the contents of “Serial No.” field of the selected certificate.



## 5.1.9 IP Address Assignment

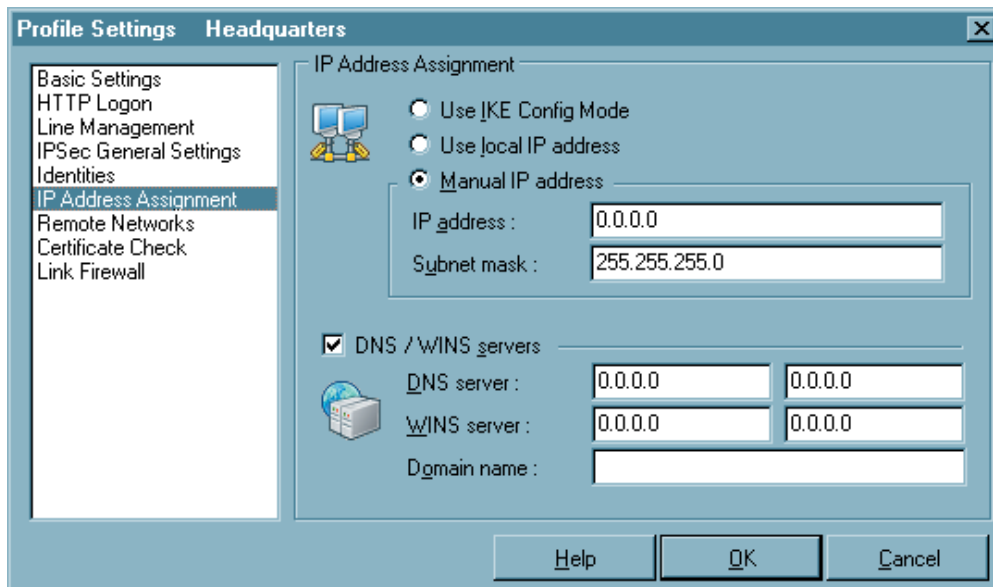

*In this parameterfield you can determine how to assign IP addresses. Moreover the server, assigned automatically by the PPP negotiation, can be changed with an alternativ server. Therefore the network settigs of the operation system must be switched to DNS mode.*

### **Parameters:**

- Use IKE Config Mode
- Use local IP address
- Manual IP address
- DNS/WINS
- DNS server
- WINS server
- Domain Name

## ■ Use IKE Config Mode

IP addresses and DNS servers are assigned via the IKE Config Mode protocol (Draft 2). All WAN interfaces can be used for the NAS dial-in.

DPD (Dead Peer Detection) and NAT-T (NAT Traversal) are automatically executed in the background for “IPSec Tunneling” if supported by the destination gateway. The IPSec client uses DPD to check, in regular intervals, whether the other side is still active. If the other side is inactive, then an automatic connection-disconnect occurs. Using NAT Traversal is automatic with the IPSec client and is always necessary if network address translation is used on the side of the destination system device.

## ■ Use local IP address

In this case the currently configured IP address (DHCP as well) of the PC is used for the IPSec client.

## ■ Manual IP address

This is the IP address and the subnet mask; these can be freely entered here. In this case the address entered here is used, regardless of the configuration in the network settings.

## ■ DNS/WINS

IKE Config Mode, if configured and available, enables dynamic assignment of client IP addresses, DNS / WINS server addresses and domain name.

Activating this function you can define an alternative DNS Server as opposed to using the one that is automatically assigned during the PPP negotiation to the NAS/ISP.

## ■ DNS server

The IP address of the DNS server entered will be the one used instead of the DNS server assigned during the PPP negotiation.

## ■ WINS server

The IP address of the WINS server entered will be the one used instead of the WINS Server assigned during the PPP negotiation.

## ■ Domain Name

This is the domain name, which otherwise is transferred to the system per DHCP in the network settings.

## 5.1.10 Remote Networks

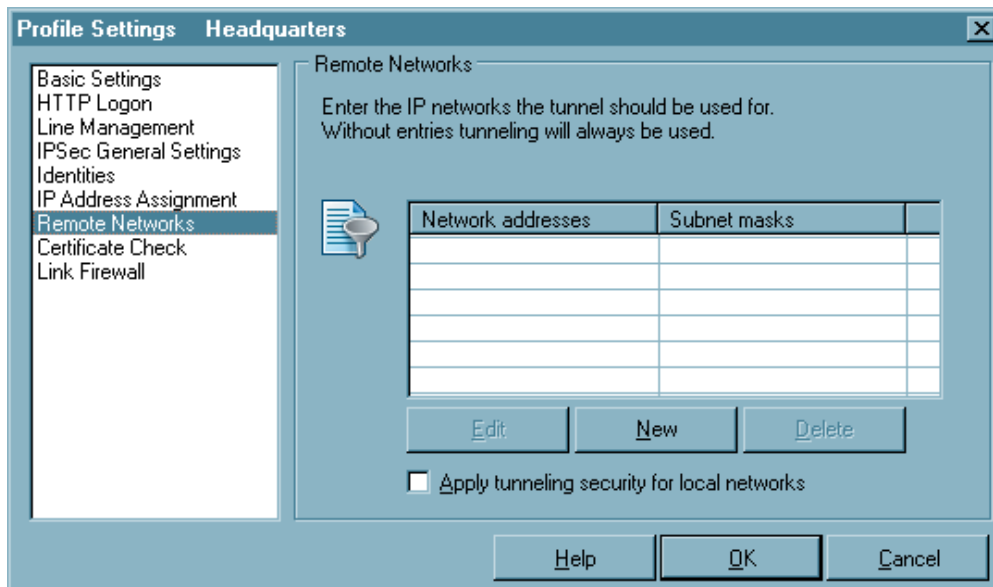

*In this folder you can precisely define the IP Network(s) to which the Client can communicate with via VPN tunnels. If you are using tunneling and you have made no entries in this folder, then your communications will always be established only to the tunnel end-point (VPN gateway). However if you would like to alternatively communicate with your central site using tunneling as well as the Internet, then you must define the IP Networks in your company that you wish to communicate with. Then you can toggle between the Internet and your company's VPN gateway. This is also referred to as "Split Tunneling".*

### Parameters:

- Network addresses | Remote Networks
- Subnet masks
- Apply tunneling security for local networks

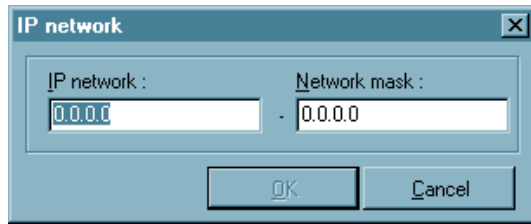

Click on the “New” button to enter the IP address of the network and the network mask in the window that will appear (left).

### ■ Network addresses | Remote Networks

In this window enter the address of the IP Network(s) that you want to reach via the gateway. These addresses are available from your administrator.



Note: Be sure that IP addresses entered in this field are not the same subnet as the gateway.

### ■ Subnet masks

In this window enter the address(es) and netmask(s) of IP Network(s) that you want to reach via the gateway. These addresses are available from your administrator.



Note: Be sure that IP addresses entered in this field are not the same subnet as the gateway.

### ■ Apply tunneling security for local networks

If you wish to encrypt the local LAN traffic by means of VPN tunneling enable this function.

## 5.1.11 Certificate Check

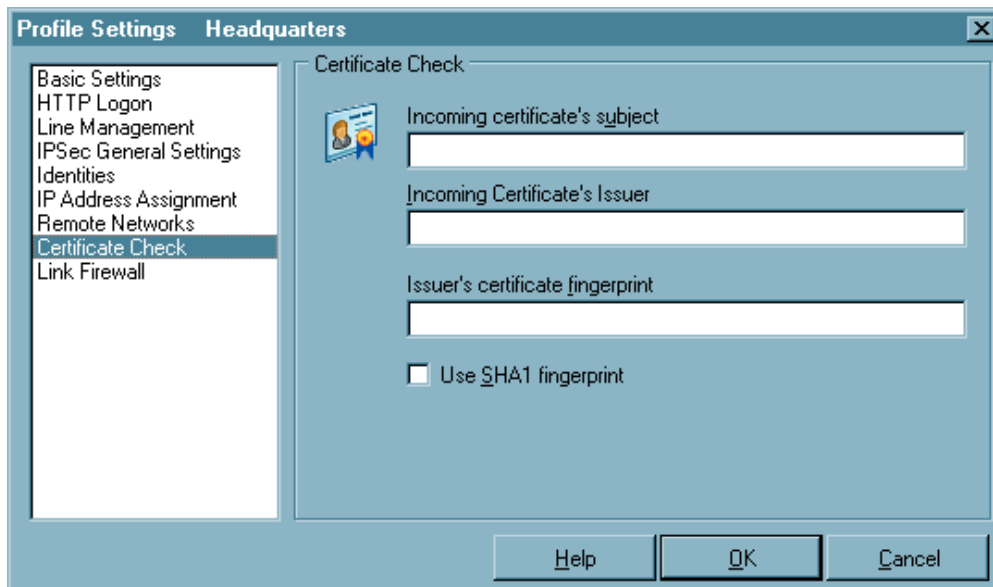

You can specify in the “Certificate Check” parameter field, per destination system, which entries must be present in a certificate from the other side (Secure Server) (see →Display Incoming Certificate, General). See also →Further Certificate Checks.

### See also:

- Incoming certificate's subject
- Incoming certificate's Issuer
- Issuer's certificate fingerprint
- Use SHA1 fingerprint
- Further certificate checks

## ■ Incoming certificate's subject

All attributes of the user, to the extent known – even with wildcards -, can be used as user certificate entries of the other side (server). In this regard compare the entries that are always listed under users for “Display Incoming Certificates”.

Use the attribute name abbreviations for this. The attribute type abbreviations for certificate entries have the following meaning:

```

cn      = Common Name / Name
s       = Surname / Nachname
g       = Givenname / Vorname
t       = Title / Titel
o       = Organisation / Firma
ou      = Organization Unit / Abteilung
c       = Country / Land
st      = State / Bundesland, Provinz
l       = Location / Stadt, Ort
email   = E-mail

```

Example:

```
cn=VPNGW*, o=ABC, c=de
```

The common name of the security server is verified here only until the wildcard “\*”. All following positions can be as desired, like 1 - 5 as numbering. The organizational unit must always be ABC in this case and Germany must be the country.

## ■ Incoming certificate's Issuer

All attributes of the user, to the extent known – even with wildcards -, can be used as user certificate entries of the other side (server). In this regard compare the entries that are always listed under users for “Display Incoming Certificates”.

Use the attribute name abbreviations for this. The attribute type abbreviations for certificate entries have the following meaning:

```

cn      = Common Name / Name
s       = Surname / Nachname
g       = Givenname / Vorname
t       = Title / Titel
o       = Organisation / Firma
ou      = Organization Unit / Abteilung
c       = Country / Land
st      = State / Bundesland, Provinz
l       = Location / Stadt, Ort
email   = E-mail

```

Example:

```
cn=ABC GmbH
```

Only the common name of the issuer is verified here.

## ■ Issuer's certificate fingerprint

To prevent an unauthorized person that imitates a trusted CA, from using a counterfeited issuer certificate, the issuer's fingerprint can also be entered if it is known.

## ■ Use SHA1 fingerprint

The algorithm for fingerprint generation can be either MD5 (Message Digest version 5) or SHA1 (Secure Hash Algorithm 1).

### *Further certificate checks*

In addition to the certificate verification according to content a certificate check is executed on the Secure Client in many respects.

#### **1. Selection of the CA Certificates**

The corporate network administrator specifies which issuers of certificates can be trusted. This is done by copying the CA certificates of his choice into the \ncple\ca-certs\ Windows directory. The copying over can be automated with diskettes in a software distribution, if the issuer certificates are located in the root directory of the first diskette at the installation. Afterwards issuer certificates can be automatically distributed via the Secure Update Server, or if the user has the requisite write authorizations in the designated directory – they can be set by the user himself (see →Display CA Certificates).

The formats \*.pem and \*.crt are supported for issuer certificates. They can be viewed in the monitor under the menu item “Connection / Certificates / Display CA Certificates”.

If the issuer certificate of another side is received, then the client determines the issuer, then searches the issuer certificate, first on Smart Card or in the PKCS#12 file, and then in the NCPLE\CACERTS\ directory. If the issuer certificate cannot be located, then the connection cannot be established.

If no issuer certificates are present, then no connection will be permitted.

## 2. Check of Certificate Extensions

Certificates can contain extensions. These serve for the linking of additional attributes with users or public keys, that are required for the administration and operation of the certification hierarchy and the revocation lists. In principle, certificates can contain any number of extensions, including those that are privately defined. The certificate extensions are written in the certificate by the issuing certification authority.

Three extensions are significant for the Secure Client and the Secure Server:

- `extendedKeyUsage`
- `subjectKeyIdentifier`
- `authorityKeyIdentifier`

*extendedKeyUsage:*

If the `extendedKeyUsage` extension is present in an incoming user certificate, then the Secure Client checks whether the defined extended application intent is “SSL Server Authentication”. If the incoming certificate is not intended for server authentication, then the connection will be refused. If this extension is not present in the certificate, then this will be ignored.

Please note that the SSL server authentication is direction dependent. This means that the initiator of the tunnel establishment checks the incoming certificate of the other side, if the `extendedKeyUsage` extension is present, then the intended purpose must contain “SSL Server Authentication”. This applies as well for callback to the Client via VPN.

*subjectKeyIdentifier / authorityKeyIdentifier:*

A key identifier is an additional ID (hash value) to the CA name on a certificate. The `authoritykeyidentifier` (SHA1 hash over the issuer’s public key) on the incoming certificate must agree with the `subjectKeyIdentifier` (SHA1 hash over the public key of the owner) on the corresponding CA certificate. If no CA certificate is found then the connection is rejected.

The `keyidentifier` designates the public key of the certification authority and thus not only one, but a series of certificates if required. The use of the key identifier allows a greater flexibility for the determining a certificate path. In addition, the certificates that possess the `authoritykeyidentifier` extension do not need to be revoked if the CA issues a new certificate when the key remains the same.



### 3. Checking Revocation Lists

The Secure Server can be provided with the associated CRL (Certificate Revocation List) for each issuer certificate. It will be copied into the \ncple\crls\ Windows directory. If a CRL is present, then the Secure Client checks the incoming certificates to see if they are listed in the CRL. The same applies for an ARL (Authority Revocation List) that must be copied into the \ncple\arls\ Windows directory.

If incoming certificates are contained in the CRL or ARL lists, then the connection is not permitted.

If CRLs or ARLs are not present, then no check takes place in this regard.

## 5.1.12 Link Firewall

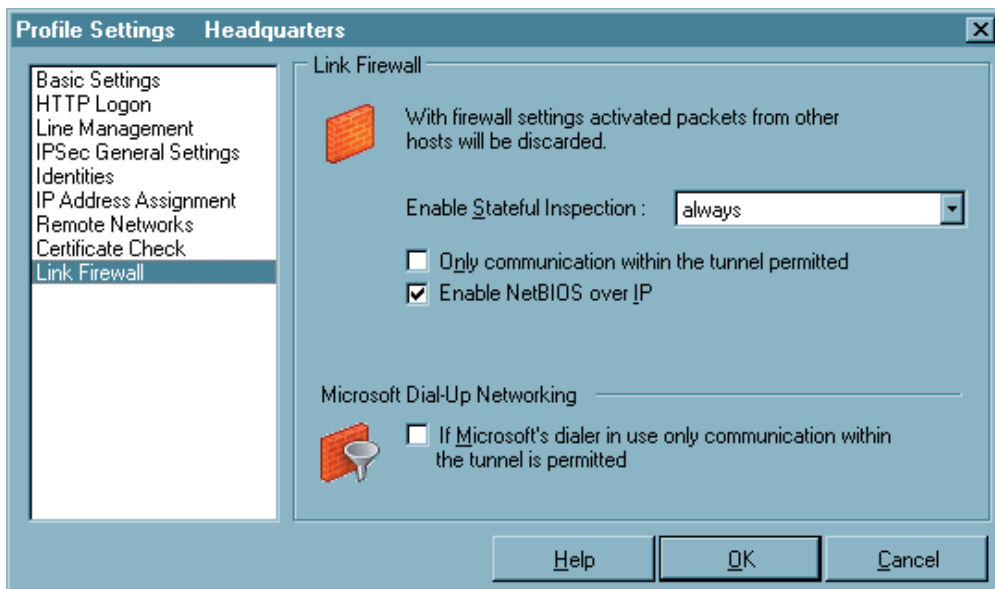

The Link Firewall configuration field with extended configuration possibilities is included in this client. The firewall settings can also be used to protect the RAS connections. The activated firewall is displayed on the monitor as a symbol (wall with arrow). A firewall's fundamental task is to prevent hazards from the Internet from spreading within the corporate network. This is why a firewall is also installed at the junction between corporate network and the Internet. It checks all incoming and outgoing data packets and decides whether a data packet will be permitted through or not, on the basis of previously specified configurations. The implemented technology is Stateful Inspection. Stateful Inspection is a very recent firewall technology and offers the high-est security available today for Internet connections and thus the corporate network. Security is insured from two perspectives. On one hand, this functionality prevents unauthorized access to data and resources in the central data network. On the other hand it monitors the respective status of all existing Internet connections as a control instance. Additionally, the Stateful Inspection firewall recognizes whether a connection has opened; “spawned connections” – such as is the case with FTP or Netmeeting – whose packets likewise must be forwarded. The Stateful Inspection connection presents itself as a direct line to the communication partner that may only be used for a data exchange that corresponds to one of the agreed upon rules.

### Parameters:

- Enable Stateful Inspection
- Only communication within the tunnel permitted
- Enable NetBios over IP
- If Microsoft's dialer in use only communication within the tunnel is permitted

## ■ **Enable Stateful Inspection**

off: The firewall's security mechanisms will not be used.

always: The firewall's security mechanisms will always be used, this means the PC is protected from unauthorized accesses even if no connection is established.

when connected: The PC is not vulnerable if a connection exists.

## ■ **Only communication within the tunnel permitted**

Only communication within the tunnel permitted: This function can also be switched on with activated firewall to additionally filter IP packets so that only VPN connections are possible.

## ■ **Enable NetBios over IP**

This parameter switches off a filter, which prevents NetBios frames from being transmitted over IP links.

The default setting is "Off", meaning that NetBios frames are filtered will be filtered out of the data stream.

When this parameter is activated, NetBios frames will be included in the data stream over IP. This may be desirable when using Microsoft Networking in conjunction with the Secure Client.

## ■ **If Microsoft's dialer in use only communication within the tunnel is permitted**

When using the Client Monitor this function prevents communication to the Internet via the RAS Dialer.

## 6. Establishing a Connection

### ■ Establishing a Connection to the destination system

Provided the software is installed properly and the profile parameters are configured correctly a dial-up to the destination system can take place. Part of the configuration is to define the mode with which this connection is to be established. There are three modes to select from: automatic, manual and variable. You define the connection mode of the destination system in the Phonebook under “Line Management – Connection Mode”.

#### *Automatic (default):*

The Client works on the principle of LAN emulation, whereas with Microsoft RAS, every connection has to be established manually. This means that the Secure Client will automatically activate a connection in accordance with your application program requirements to the destination selected in the Phonebook.

#### *Manual:*

This means that you must manually activate a Connect. This is done by clicking on “Connection” in the Monitor and then selecting “Connect”.

#### *Variable:*

When this mode is selected, the connection must be established “manually”. Subsequently, the mode adapts according to the manner in which the connection was terminated:

- If the connection was terminated as a result of a timeout, then the following connection will be automatically initiated as required.
- On the other hand if the connection was terminated manually, then the following connection must then also be established manually.

### ■ Connect

Independent of the connection mode, the monitor always displays the connection status as explained in the following example:

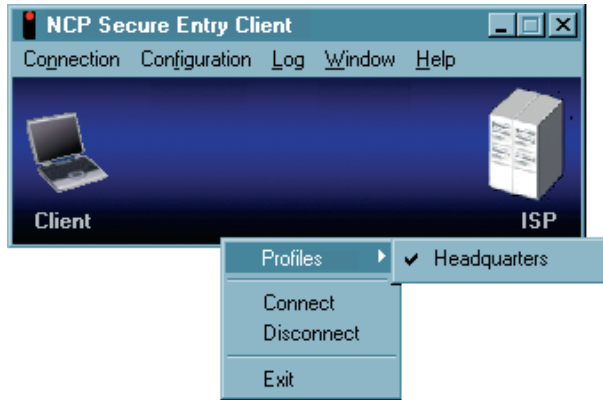

First step is to select a destination system to connect to – click the right mouse button to display the menu.



To then manually establish a connection click the right mouse button to display the menu and then select “Connect”.

If the use of a (Soft-) Certificate was configured you first have to enter the PIN.

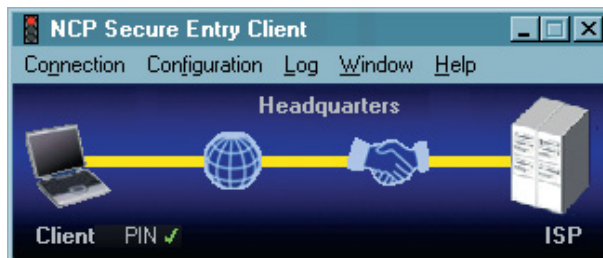

Then a link to the Internet Service Provider (ISP) is built indicated by a yellow line. The dial-up negotiation is displayed with a symbol representing a globe and the authentication status with a handshake. Upon doing so the symbols change according to the current status.



light blue = Link building stage  
dark blue = Stage passed

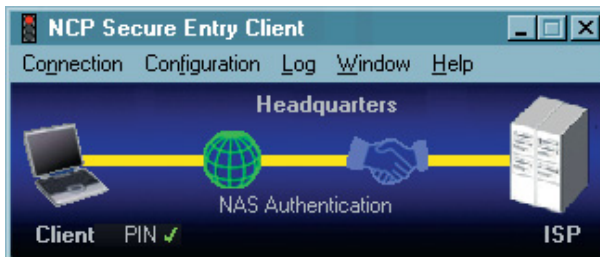

green = successfully negotiated stage.

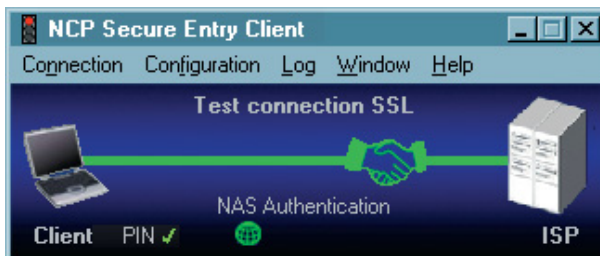

The successfully passed stages are displayed by minimized symbols.

Upon a successful authenticated connection with the ISP/Network Access Server (green line and green handshake symbol) ...

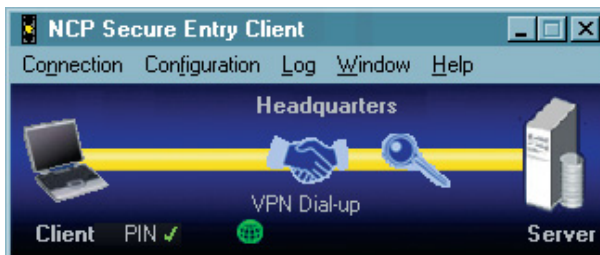

... a tunnel is built indicated by a new yellow bar and the second dial-up to the VPN Gateway starts. Here authentication is necessary as well. In addition under the use of Test connection SSL an encryption (key) is configured.

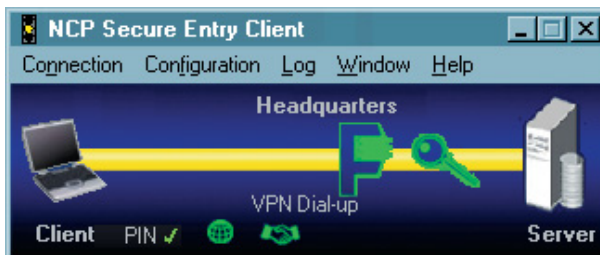

If the configuration of the destination system is set to utilize compression, you can configure compression as well.

If the last stage of the link built (here encryption resp. decryption) is successfully passed, the traffic light switches to green...

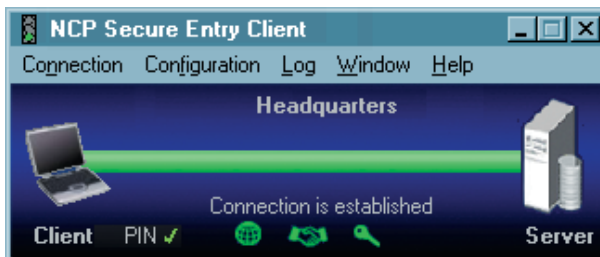

... as well as the tunneling. Now a connection is established.

Please note that green traffic lights indicates that a link is built and that communication costs are being incurred!



## ■ Client Logon

If the Client Logon to the Network Access Server occurs before the Windows Logon to the remote domain, (“Logon Options” (see →Monitor, Logon Options), the connection is established in the same way as described under “Connect” (see above).

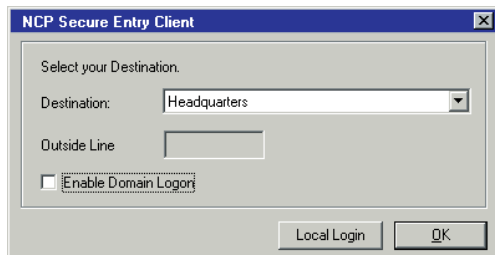

To initiate a link to be built, select the destination system to connect to and then click on the OK button.

Local logoff:

With a click on this button the link build is stopped.

Activate Domain Logon: With this option a safe WAN domain logon is possible, even if the logoff was not executed correctly. The logon takes some seconds. This function is not necessary if the shut down of the PC was made correctly and mapped drivers were disconnected properly.

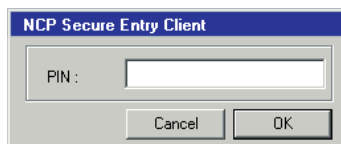

If the use of a (Soft-) Certificate was configured – like example destination Test connection SSL – you first have to enter the PIN.

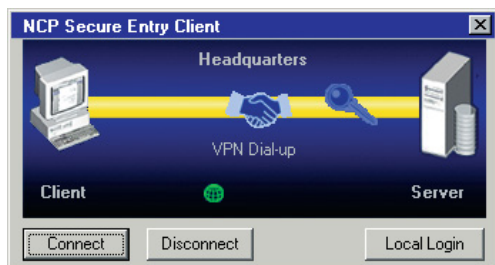

The following stations of the link built in the same procedure as described above under “Connect”...

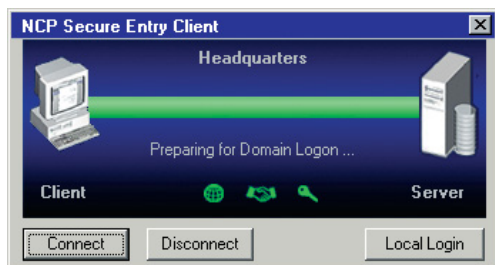

... until the connection is established.

## ■ Passwords and User Names

The password (see →Dial-Up Network, Password) is used for identifying yourself to the remote Network Access System (NAS) when establishing a connection to your Destination, or alternatively to your Internet Service Provider (ISP) if you are communicating across the Internet. The password ID can include up to 256 characters. Normally the password will be assigned to you by your Destination (e.g. your company Headquarters, User Help Desk, Internet Service Provider, etc.), because it must be supported and accepted by the NAS, for authentication purposes. Upon entering your password all characters will be displayed as an asterisk (\*) in order to keep them from being overlooked by someone else. Therefore it is necessary to be very careful that you enter your password exactly the way in which it was assigned to you (pay attention to upper case and lower case characters).



Even if you selected “automatically” as connection mode (see →“Establishing a Connection to the destination system”), you have to establish the first connection manually and enter the password. For every additional automatically established connection the password is adopted automatically, until you reboot your PC or you select a different destination system. This means that even though the function “Save Password”(see →Dial-Up Network) was not activated, automatic connections can still be made where this cached password is used to authenticate. When (re)booting your PC the once entered password is then deleted (Please notice →Logon Options).



If you do not want to delete the password when (re)booting your PC you have to activate the function “Save Password” (see →Dial-Up Network). Please notice that for security reasons you must be aware that should some unauthorized person use your PC, they will be able to use your password. Therefore caution should be used when your PC is unattended.

### User ID for NAS Dial-Up

If the Password has not been entered or saved it will be requested in a separate window.

The “User Name” of the Dial-Up Network must always be entered in the configuration of the profile. Without this User ID a dial-up to the NAS is impossible (see →Dial-Up Network)



## User Name and Password for Extended Authentication

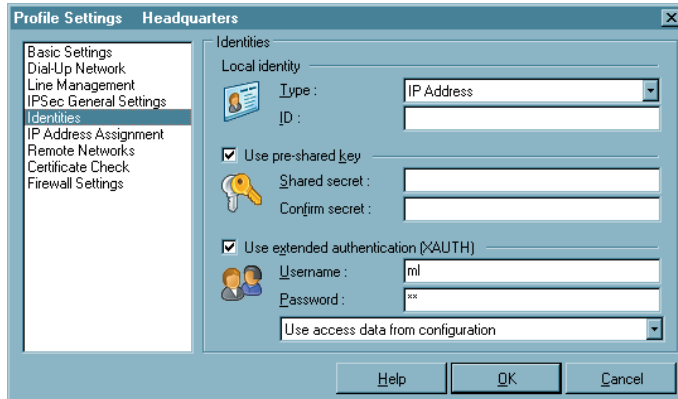

If you use Extended Authentication, User Name and Password must be entered in the configuration folder of the profile. Otherwise the establishing of a connection will not be successful (see →Profile Settings, Identities, Use extended authentication (XAUTH)).

## ■ Disconnection and error

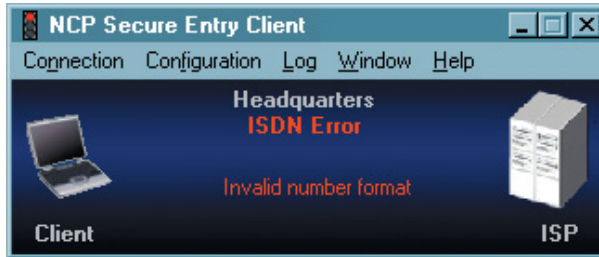

If an error occurs, a connection will not be established and the reason is displayed in the monitor (please notice the passage “ISDN CAPI Error Codes“)



## ■ Disconnect

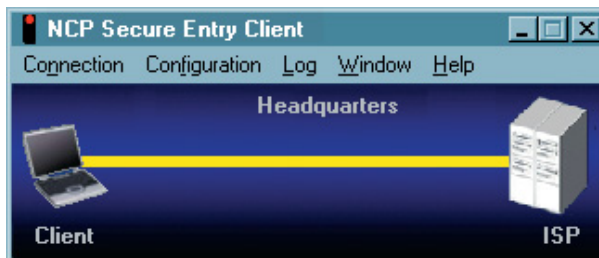

With the function “Disconnect” a connection can be manually terminated. If you want to keep the possibility to disconnect manually you have to set the connection mode to “manually” and deactivate the active Timeout by setting it to zero (0) (→Connection Mode).

If the connection is terminated, the color of connection line changes until it disappears and the lamps of the traffic light changes from green to red during the period of offline.

## ■ Disconnect (the Monitor)

If the connection is still established, with a click on this menu item or on the “Disconnect” button, the monitor can be closed as well. Please note that the connection is not automatically terminated by closing the Monitor. If the link should be established although the monitor is closed and fees may occur, the software asks you explicitly for a prompt (see picture)

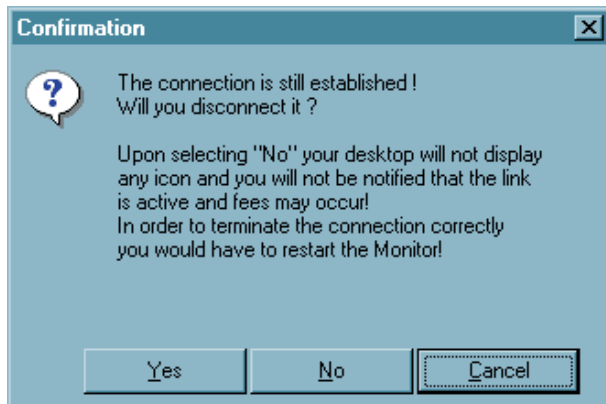

**Upon selecting “No” your desktop will not display any icon and you will not be notified that the link is active and fees may occur! In order to terminate the connection correctly you would have to restart the Monitor!**

## 7. Examples and Explanations

This section of the handbook discusses some essential routing concepts. The Secure Client configuration is illustrated with several different examples.

## 7.1 IP Functions

To correctly configure an IP network, you must adhere to the procedure for IP addressing. Below you will find some guidelines and terminology. For additional information about IP networks the standard literature is recommended.

### 7.1.1 IP Network Devices

IP addresses are assigned to the component interfaces of an IP network. These components are also called hosts or computers. Multiple networked components (e.g. routers) may also be allocated to various addresses. The term host-address marks the IP address of the host of an IP process, regardless of the actual physical structure of the components or the interfaces.

### 7.1.2 IP Address Structure

IP addresses have a length of four octets, 32 bits (4 bytes) and are written in dotted decimal or hexadecimal notation. E.g.:

198.10.6.27 or  
C6.0A.06.1B or  
0xC6.0x0A.0x06.0x1B

The addresses are divided into a network segment, which identifies the network, and a local address, the host segment, identifying the host of the network. All hosts within a unique network share the same host segment. All devices inside a unique network share the same network segment. Each also has a unique host segment.

There are three classes of Internet addresses each is used according to how many bytes the IP address uses for network segment and host segment.

*Class A*, large networks: network numbers 1 - 127

For class A addresses the highest bit is equal to zero, the next seven bits represent the network segment and the remaining 24 bits represent the host segment.

The network segment needs 1 byte (max. 126 different networks)

The host segment needs 3 bytes (max. 2 to the 24th power = 16.777.216 various hosts).

In this manner a maximum of 127 different networks, each with maximum of 16.777.216 different hosts may be addressed.

*Class B*, mid-size networks: network numbers 128 -191

For class B addresses the two highest bits have the values 1 and 0, the following 14 bits represent the network segment and the remaining 16 bits represent the host segment

The network segment needs 2 Byte (max. 16.384 various networks)

The host segment needs 2 bytes (max. 2 to the 16th power = 65.526 different hosts)

In this manner a maximum of 16.384 different networks, each with maximum of 65.526 different hosts may be addressed.

*Class C*, small networks: network numbers 192 - 223

For class C addresses the three highest bits have the values 1, 1 and 0, the following 21 bits represent the network segment and the remaining 8 bits represent the host segment.

The network segment needs 3 bytes (max. 2.097.152 various hosts)

The host segment needs 1 byte (max 256 various hosts)

In this manner a maximum of 2.097.152 various networks, each with maximum of. 256 different hosts may be addressed.

e.g.:

	Network		Host	
Class A:	122.	087.	156.	045
Class B:	162.	143.	085.	132
Class C:	195.	076.	212.	024

Please note, when assigning the addresses, that each physical host must be able to use several IP addresses. A workstation can function with one IP address. A router needs an IP address for each interface however at least two – one for the connection to the local network (LAN IP Address) and one for the connection to the WAN side.

### 7.1.3 Subnet Masks

In a wide area network various physically separated nets (LANs) may belong to the same network (WAN) with the same network number. On the basis of the network number alone no router can decide if it should create a connection to a physically different network within the WAN or not. Thus the network (WAN) must be subdivided into smaller segments (LANS) that each receive their own address block. Each address block of the individual physical networks is designated as a subnet. Through this subdivision of a network into subnets the hierarchy network and computer is extended to a hierarchy of network, subnet, and computer.

This extended hierarchy makes it easier to locate a computer in the total network (WAN). An example using the telephone nomenclature can illustrate how this works. The area code designates in which area the telephone is located. This hierarchy insures also a certain access security. For example a computer on a subnet will not automatically have access to the resources of another subnet. Or to use a specific case a production worker does not have access to the personnel department data provided that the subnet masks have been selected according to corporate departments.

The subnet mask indicates the location of the subnet field in an IP address. The subnet mask is a binary 32-bit-number like an IP address. It has a "1" in every position of the network segment and an IP address (according to the network class within the first to the third octet). The next octet shows the position of the subnet field. The digits 1 adjacent to the subnet field indicate the subnet bits. All remaining positions with "0" remain for the host segment.

#### Examples

##### *Example 1:*

The subnet mask is used for the interpretation of the IP address. Accordingly an address 135.96.7.230 with the mask 255.255.255.0 may be interpreted as follows: The network has the address 135.96.0.0, the subnet has the number 7, the host number 230. An IP address with 135.96.4 belongs to a different subnet (4) on the same network.

Binary representation:

135.96.7.230	=	10000111	11000000		00000111		11100110
135.96.4.190	=	10100000	10010101		00000100		10111110
255.255.255.0	=	11111111	11111111		11111111		00000000
		Network			Subnet		
255.255.248.0	=	11111111	11111111		11111 000		00000000

If the net mask did not have a standard value of 255.255.255.0 in the example shown above, but rather an IP address of 255.255.248.0 then the IP addresses would be located in the same subnet, and routing would not take place.

*Example 2:*

Two IP addresses with 160.149.115.8 and 160.149.117.201 and the subnet mask 255.255.252.0 are located in the same network, but belong to different subnets.

Binary description:

```

160.149.115.8   = 10100000 10010101 | 011100 | 11 00001000
160.149.117.201 = 10100000 10010101 | 011101 | 01 11001001
255.255.252.0   = 11111111 11111111 | 111111 | 00 00000000
                    network           | subnet |

```

The choice of a suitable subnet mask depends on the network class, the quality of the possible subnets, their quantity and their growth potential. For planning purposes please refer to the standard tables or to a subnet calculator.

Subnet tables class C:

Subnet bits	Host bits	netmask	subnets	host
2	6	255.255.255.192	2	62
3	5	255.255.255.224	6	30
4	4	255.255.255.240	14	14
5	3	255.255.255.248	30	6
6	2	255.255.255.252	62	2

(Calculation: 2 to the power of n minus 2 = quantity of subnets / computers where n is the quantity of subnets / host bits)

With the subnet mask 255.255.255.240 a class C network is divided into subnets. This net mask allows a total of 14 subnets each with a maximum of 14 computers.

```

255.255.255.240  11111111 11111111 11111111 | 1111 | 0000
199. 9. 99.130   11000111 00001001 01100011 | 1000 | 0010 Subnet-Number 8
199. 9. 99.146   11000111 00001001 01100011 | 1001 | 0010 Subnet-Number 9
                    Netzwerk           |Subnet| Host

```

## ■ Standard masks

Subnet mask for class A:255. 0. 0. 0

Subnet mask for class B:255. 255. 0. 0

Subnet mask for class C:255. 255. 255. 0



## ■ Reserved addresses

Some IP addresses may not be assigned to network devices. These include the network or subnet address and the circular address for networks ref. subnets. Network addresses consist of network number and the host field filled with binary 0's (e.g. 200.1.2.0, 162.66.0.0., 10.0.0.0) – also Loop Back, there is no transmission into the network. The circular address consists of network numbers and the host segment with binary 1's (e.g. 200.1.2.255, 162.66.255.255., 10.255.255.255) – therefore also an “All One Broadcast”, all components of a network will be addressed.

*Example:*

198.10.2.255	addressed to all stations in the network 198.10.2.
255.255.255.255	addressed to all stations of all connected nets
0.0.0.0	All Zero Broadcast: invalid address.

Please note that this is often used for standard settings.

### 7.1.4 Using IP Addresses:

- Each address in your enterprise-wide network should be unique. Make sure that this is the case when connecting to the Internet or linking new networks.
- Use a logical, comprehensible addressing scheme, e.g. organized according to administrative units, buildings, departments etc.
- For connection to the Internet, you will need an official, unique, Internet address.
- If possible, do not assign any addresses in which the network or host segment end in “0”. This might lead to misinterpretations and to undefined errors in the network.
- Subnet masks will only be evaluated by the Internet protocol, if the network numbers of all communication partners are the same.

The subnet masks have network segments of different length just as do the address classes.

## 7.2 Security



Configuration parameters for IPSec for implementation in remote access environments are collected in the parameter field “IPSec General Settings”. This section describes some possibilities of configuration.

### 7.2.1 IPSec – Overview

IPSec can only be implemented for IP data traffic. The IPSec specification includes not only Layer 3 tunneling but also includes all necessary security mechanisms like strong authentication, key exchange and encryption.

The IPSec RFC’s (2401-2409) permit the development of a VPN with specified IP security. IPSec tunneling and security are thoroughly described making a complete VPN framework available. In principle it is possible to use vendor-independent components. For site-to-site VPN’s the gateways may be supplied by different manufacturers, for end-to-site gateways the clients may be supplied by another manufacturer.

The establishment of a connection to IPSec traffic is based on the Internet Key Exchange Protocol (IKE).

#### ■ IPSec – General Functional Description

In every IP host (client or gateway) that supports IPSec there is an IPSec module i.e. an IPSec engine. This module examines each packet for certain characteristics in order to apply the appropriate security negotiation to it.

Testing of the outgoing IP packets from the IP stack occurs relative to a Secure Policy database (SPD). With this all configured SPDs will be processed. (When using the IPSec Client, the SPDs are only stored at the central site gateway.)

The SPD consists of multiple entries (SPD entries), which in turn contain a filter portion. The filter portion or Selector of an SPD entry consists primarily of IP addresses, UPD, and TCP ports as well as other IP header-specific entries. If the values of an IP packet agree with the values from the SPD entry Selector portion, then further determination as to what should be done with this IP packet is made from the SPD Entries. The packet can simply be allowed through (permitted), or discarded, or certain security policies of the IPSec process can be imposed on the packet. These security policies are also described in the SPD entry.

If, in this manner, it is determined that an IP packet is linked with an SPD entry that triggers an IPSec process, then it will be examined to see whether a security association

(SA) exists for this SPD entry. If an SA does not yet exist then first an authentication and a key exchange will take place before the negotiation of an SA (see below →IPSec Negotiation Phase 1)

After the SA negotiation, negotiations follow for data packet encryption (ESP) and/or authentication (AH) of the data packets.

The SA describes which security protocol should be used. ESP (Encapsulating Security Payload) supports the encryption and authentication of IP packets. AH (Authentication Header) supports only the authentication of IP packets. The SA also describes the operating mode in which the security protocol should be used either Tunnel or Transport mode. In Tunnel mode an IP header is inserted, in Transport mode the original header is used. Additionally the SA describes which algorithm will be used for authentication, which encryption method (for ESP) and which key should be used. Of course the other side should work according to the same SA.

If the SA is negotiated, then each packet will be processed according to the operating mode and protocol, either Tunnel or Transport, and either ESP or AH respectively. The IPSec Client uses always the IP protocol in Tunnel mode.

## 7.2.2 Firewall Settings

The firewall settings consists mainly of IP addresses, UDP and TCP ports, as well as other IP header-specific entries. If the values of an IP packet agree with values from the selector portion, then further determinations from the SPD entries specify how to proceed with this IP packet.

Following, the entries for configuring the IPSec Client:

Command

permit, deny, disabled

IP Protocol

This is the transport protocol that can be ICMP, TCCP, or UDP. One of these offered protocols can be selected or (any) can be used.

Source IP address

This can be a simple IP address or an address range. The latter is necessary if a shared SA, behind a firewall, supports multiple output systems for example.

Destination IP address

This can be a simple IP address or an address range. The latter is necessary if a shared SA, behind a firewall, supports multiple output systems for example.

Source Port

These can be either individual TCP or UDP port numbers or a range of port numbers. You determine the port numbers with allocated service by using the Select button [...].

Destination Port

These can be either individual TCP or UDP port numbers or a range of port numbers. You determine the port numbers with allocated service by using the Select button [...].

### 7.2.3 SA Negotiation and Policies

In order to initiate the IPSec filter process the SA must first have been negotiated. One SA negotiation takes place for the phase 1 (IKE policy) and at least two (for incoming and outgoing connection) for phase 2 (IPSec policy). [For every destination network (see →Profile Settings, Remote Networks) two SAs are also negotiated.].

#### ■ Phase 1 (IKE Policy)

IPSec establishes the control channel in tunnel mode over the IKE protocol to the IP address of the secure gateway. In Transport mode it is established directly to the IP Address of the other side.

You define parameters to determine encryption and authentication type over the IKE protocol in the IKE Policies. Thus an authentication can be achieved via a pre-shared key or RSA signature. (These IKE guidelines are referenced in the IPSec editor.)

#### ■ Phase 2 (IPSec Policy)

The SA negotiation is concluded over the control channel. From the IPSec engine the SA is handed-off to the IKE protocol that it transmits over the control channel to the IPSec engine.

## Control Channel and SA Negotiation

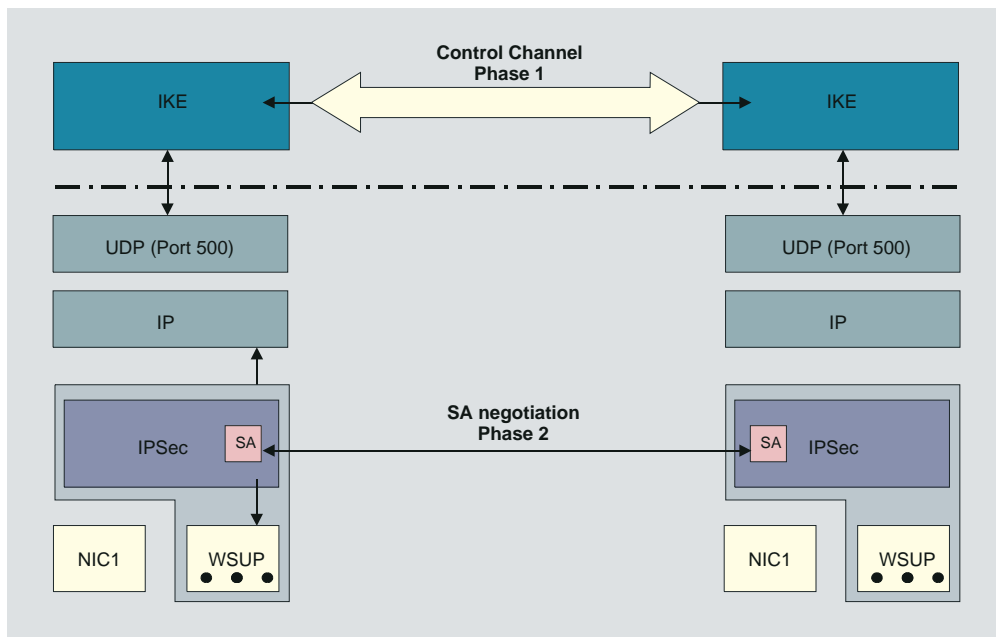

*Description of the Graphic:*

The SA must first have been negotiated in order for the IPsec process to start. This SA negotiation takes place once per SPD (which can be created for different ports, addresses, and protocols). This SA negotiation requires a control channel.

First the client must create a Layer 2 (PPP) link to the provider. With this link the client is assigned a new IP address each time he dials in. The IPsec module in the client receives an IP frame with the destination address of the corporate network. An SPD entry for this IP frame will be found but no SA exists at this time. The IPsec module then issues a request to the IKE module to negotiate an SA. Thus the requested security policies as present in the SPD entry are handed off to the IKE module. Negotiating an IPsec-Security Association (IPsec-SA) is considered a Phase 2 negotiation. However before an IPsec-SA can be negotiated with the other side (Secure Server) a kind of control channel from the client to the Secure Server (VPN) gateway must first exist. This control channel is established via the Phase 1 negotiation whose result is an IKE- Security Association (IKE-SA). Thus the Phase 1 negotiation undertakes the complete authentication of the client relative to the Secure Server and generates an encrypted control channel. Then the Phase 2 negotiation (IPsec-SA) can immediately take place over this control channel. The Phase 1 negotiation is a handshake over which the exchange of certificates is possible and it contains key exchange for the control channel.

## ■ IKE Modes

Essentially two types of IKE policies can be configured. They differ according to the type of authentication, which can be either over Pre-shared Key or RSA signature. Each of the two types of Internet Key Exchange can be executed in two different modes. These are; Main Mode also referred to as Identity Protection Mode or Aggressive Mode. These modes are differentiated by the number of messages and by the encryption.

In Main Mode (standard setting) six messages are sent over the Control Channel and the last two messages are encrypted. The last two messages contain the user ID, the signature, the certificate and, if required, a hash value. This is why it is also known as Identity Protection Mode.

In Aggressive Mode only three messages are sent over the Control Channel and nothing is encrypted.



You determine the IKE mode (Exchange Mode), Main Mode or Aggressive Mode “Security” parameter fields under “Link Profiles” (for a dynamic SPD) and under “IP-Sec, Secure Policy Database” (for a static SPD). (See also →Exchange Mode).

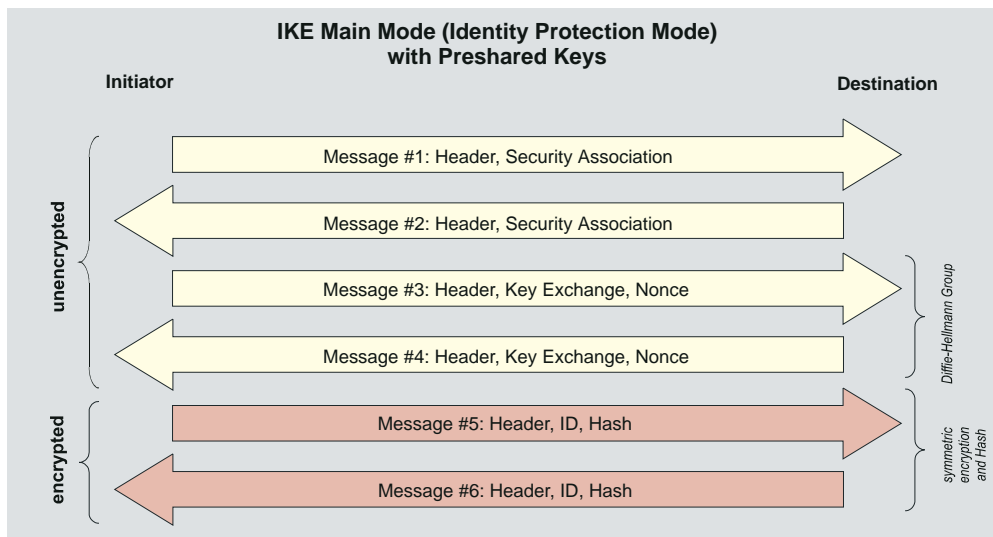

*If the pre-shared key method is used in Main Mode then the client on the VPN/Gateway must be clearly identifiable by his IP address. This is because the pre-shared key will be introduced into the symmetric key calculation and encrypted before the transfer of any other information that could identify the client. However a client dialing in to the provider is not identifiable by an IP address because he receives a new one with each dial in. This means that in Main Mode only the same pre-shared key can be given out which weakens the authentication.*

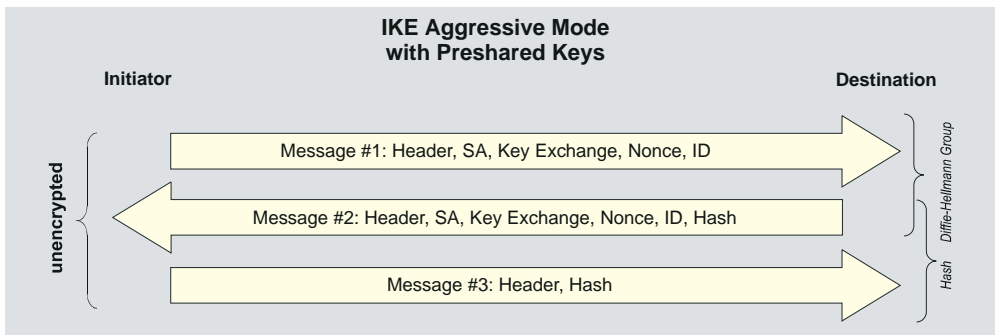

*One possibility to avoid a general pre-shared key would be to use the Aggressive Mode (see above graphic), however in this case the client ID is not encrypted.*

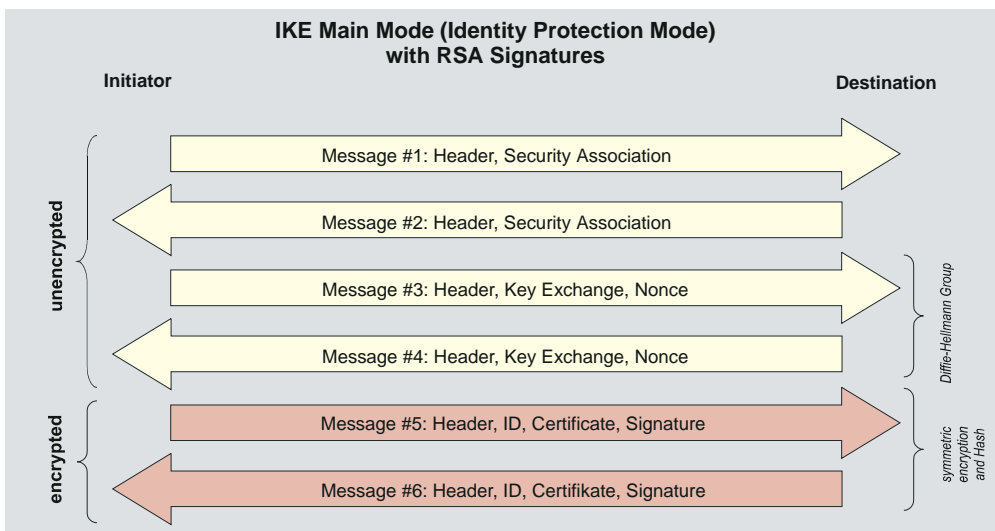

*If RSA signatures have been set (Graphic above and below), then this means that certificates will be used and thus pre-configuration of all “secrets” is no longer relevant.*





## 7.2.4 IPSec Tunneling

The compatibility with other manufactures relies on the ability to conform to the IPSec RFC's and to some drafts (official or not). The IPSec Client running in IPSec compatible mode supports the following RFC's and drafts:

- RFC 2104 - Keyed-Hashing for Message Authentication
- RFC 2401 - Security Architecture for the Internet Protocol
- RFC 2403 - The Use of HMAC-MD5-96 within ESP and AH
- RFC 2404 - The Use of HMAC-SHA-1-96 within ESP and AH
- RFC 2406 - IP Encapsulating Security Payload (ESP)
- RFC 2407 - The Internet IP Security Domain of Interpretation for ISAKMP
- RFC 2408 - Internet Security Association and Key Management Protocol (ISAKMP)
- RFC 2409 - The Internet Key Exchange (IKE)
- DRAFT - draft-beaulieu-ike-xauth-05 (XAUTH)
- DRAFT - draft-dukes-ike-mode-cfg-02 (IKECFG)
- DRAFT - draft-ietf-ipsec-dpd-01 (DPD)
- DRAFT - draft-ietf-ipsec-nat-t-ike-01 (NAT-T)
- DRAFT - draft-ietf-ipsec-nat-t-ike-02 (NAT-T)
- DRAFT - draft-ietf-ipsec-nat-t-ike-03 (NAT-T)
- DRAFT - draft-ietf-ipsec-nat-t-ike-05 (NAT-T)
- DRAFT - draft-ietf-ipsec-udp-encaps-06 (UDP-ENCAP)

### ■ Implemented Algorithms for Phase 1 and 2:

#### *Supported authentication methods for phase 1 (IKE policy)*

- RSA signature.
- PSK (Pre-shared Key)

#### *Supported symmetric encryption algorithms (phase 1 & 2)*

- DES.
- 3DES.
- AES-128, AES-192, AES-256.

#### *Supported asymmetric encryption algorithms (phase 1 & 2)*

- DH 1,2,5 ( Diffie-Hellmann )
- RSA

### ***Supported hash algorithms***

- MD5
- SHA-1

### ***Additional phase 2 support***

- PFS (Perfect Forward Secrecy)
- IPCOMP (LZS)
- Seamless re-keying

When a profile entry with IPSec tunneling is defined some defaults will be set automatically.

These defaults are:

- IKE phase 1 policies - Automatic Mode
- IKE phase 2 policies - Automatic Mode
- IKE phase 1 mode RSA - Main Mode.
- IKE phase 1 mode PSK - Aggressive Mode.



These policies and negotiation modi are set automatically but, alternatively they can be configured manually in the Phonebook. They can therefore be modified if necessary for other requirements.

## Default mode proposals

1. With the setting “Assigned by Destination” and the “Preshared Key” field left empty, the following proposals for the IKE policy will be sent to the destination by default and a certificate will be used for authentication (refer to →IKE Policy, Phase 1 Parameter):



### Notation:

EA = Encryption Algorithm (Verschlüsselung)  
 HASH = Hash Algorithm (Hash)  
 AUTH = Authentication Method (Authentisierung)  
 GROUP = Diffie-Hellmann Group Number (DH-Gruppe)  
 LT = Life Type (Dauer)  
 LS = Life Seconds (Dauer)  
 KL = Key Length (Schlüssellänge)

EA	HASH	AUTH	GROUP	LT	LS	KL
AES_CBC	SHA	XAUTH_RSA	DH5	SECONDS	28800	256
AES_CBC	MD5	XAUTH_RSA	DH5	SECONDS	28800	256
AES_CBC	SHA	RSA	DH5	SECONDS	28800	256
AES_CBC	MD5	RSA	DH5	SECONDS	28800	256
AES_CBC	SHA	XAUTH_RSA	DH2	SECONDS	28800	256
AES_CBC	MD5	XAUTH_RSA	DH2	SECONDS	28800	256
AES_CBC	SHA	RSA	DH2	SECONDS	28800	256
AES_CBC	MD5	RSA	DH2	SECONDS	28800	256
AES_CBC	SHA	XAUTH_RSA	DH5	SECONDS	28800	192
AES_CBC	MD5	XAUTH_RSA	DH5	SECONDS	28800	192
AES_CBC	SHA	RSA	DH5	SECONDS	28800	192
AES_CBC	MD5	RSA	DH5	SECONDS	28800	192
AES_CBC	SHA	XAUTH_RSA	DH5	SECONDS	28800	128
AES_CBC	MD5	XAUTH_RSA	DH5	SECONDS	28800	128
AES_CBC	SHA	RSA	DH5	SECONDS	28800	128
AES_CBC	MD5	RSA	DH5	SECONDS	28800	128
AES_CBC	SHA	XAUTH_RSA	DH2	SECONDS	28800	128
AES_CBC	MD5	XAUTH_RSA	DH2	SECONDS	28800	128
AES_CBC	SHA	RSA	DH2	SECONDS	28800	128
AES_CBC	MD5	RSA	DH2	SECONDS	28800	128
DES3	SHA	XAUTH_RSA	DH5	SECONDS	28800	0
DES3	MD5	XAUTH_RSA	DH5	SECONDS	28800	0
DES3	SHA	RSA	DH5	SECONDS	28800	0
DES3	MD5	RSA	DH5	SECONDS	28800	0
DES3	SHA	XAUTH_RSA	DH2	SECONDS	28800	0
DES3	MD5	XAUTH_RSA	DH2	SECONDS	28800	0
DES3	SHA	RSA	DH2	SECONDS	28800	0
DES3	MD5	RSA	DH2	SECONDS	28800	0

If a specific IKE proposal is entered in the IPSec configuration of profile settings, the same proposal will automatically be generated with Extended Authentication and sent.



2. If a string is entered in the “Preshared Key” field, the following proposals for the IKE policy will be sent to the destination by default and no certificate will be used for authentication.

EA	HASH	AUTH	GROUP	LT	LS	KL
AES_CBC	SHA	XAUTH_PSK	DH5	SECONDS	28800	256
AES_CBC	MD5	XAUTH_PSK	DH5	SECONDS	28800	256
AES_CBC	SHA	PSK	DH5	SECONDS	28800	256
AES_CBC	MD5	PSK	DH5	SECONDS	28800	256
AES_CBC	SHA	XAUTH_PSK	DH2	SECONDS	28800	256
AES_CBC	MD5	XAUTH_PSK	DH2	SECONDS	28800	256
AES_CBC	SHA	PSK	DH2	SECONDS	28800	256
AES_CBC	MD5	PSK	DH2	SECONDS	28800	256
AES_CBC	SHA	XAUTH_PSK	DH5	SECONDS	28800	192
AES_CBC	MD5	XAUTH_PSK	DH5	SECONDS	28800	192
AES_CBC	SHA	PSK	DH5	SECONDS	28800	192
AES_CBC	MD5	PSK	DH5	SECONDS	28800	192
AES_CBC	SHA	XAUTH_PSK	DH5	SECONDS	28800	128
AES_CBC	MD5	XAUTH_PSK	DH5	SECONDS	28800	128
AES_CBC	SHA	PSK	DH5	SECONDS	28800	128
AES_CBC	MD5	PSK	DH5	SECONDS	28800	128
AES_CBC	SHA	XAUTH_PSK	DH2	SECONDS	28800	128
AES_CBC	MD5	XAUTH_PSK	DH2	SECONDS	28800	128
AES_CBC	SHA	PSK	DH2	SECONDS	28800	128
AES_CBC	MD5	PSK	DH2	SECONDS	28800	128
DES3	SHA	XAUTH_PSK	DH5	SECONDS	28800	0
DES3	MD5	XAUTH_PSK	DH5	SECONDS	28800	0
DES3	SHA	PSK	DH5	SECONDS	28800	0
DES3	MD5	PSK	DH5	SECONDS	28800	0
DES3	SHA	XAUTH_PSK	DH2	SECONDS	28800	0
DES3	MD5	XAUTH_PSK	DH2	SECONDS	28800	0
DES3	SHA	PSK	DH2	SECONDS	28800	0
DES3	MD5	PSK	DH2	SECONDS	28800	0

The client sends the following IPSEC (phase2) default proposals.

#### Notation:

PROTO	-	Protocol (Protokoll)
TRANS	-	Transform (Transformation (ESP))
LT	-	Life Type (Dauer)
LS	-	Life Seconds (Dauer)
KL	-	Key Length (Schlüssellänge)
COMP	-	IP Compression (Transformation (Comp))

PROTO	TRANS	AUTH	LT	LS	KL	COMP	LZS
ESP	AES	MD5	SECONDS	28800	128	Yes	Yes
ESP	AES	SHA	SECONDS	28800	128	Yes	Yes
ESP	AES	MD5	SECONDS	28800	128	No	No
ESP	AES	SHA	SECONDS	28800	128	No	No
ESP	AES	MD5	SECONDS	28800	192	Yes	Yes
ESP	AES	SHA	SECONDS	28800	192	Yes	Yes
ESP	AES	MD5	SECONDS	28800	192	No	No
ESP	AES	SHA	SECONDS	28800	192	No	No
ESP	AES	MD5	SECONDS	28800	256	Yes	Yes
ESP	AES	SHA	SECONDS	28800	256	Yes	Yes
ESP	AES	MD5	SECONDS	28800	256	No	No
ESP	AES	SHA	SECONDS	28800	256	No	No
ESP	DES3	MD5	SECONDS	28800	0	Yes	Yes
ESP	DES3	MD5	SECONDS	28800	0	No	No

## 7.2.5 Further Configuration

*Pre-shared Key* or *RSA Signature*: According to the defaults through the other side, the automatic setting “Automatic Mode” can be changed as IKE policy to, “Preshared Key” or “RSA Signature” (certificate). If the other side expects “Pre-shared key”, then the key must be entered in the field. (The “Preshared Key” must be identical for all clients in this case.)

*IP addresses* and *DNS server* are assigned via the IKE Config Mode protocol (Draft 2) (currently compatible only against Cisco). All previous WAN interfaces can be used for the NAS dial-in.

The *authentication* for IPSec Tunneling is handled via the XAUTH protocol (Draft 6). If “IPSec Tunneling” is used, then additionally the following parameters must still be set in the “Identities” configuration field:

Username	=	User Name of the IPSec user
Password	=	Password of the IPSec user
User access data from configuration	=	optional

DPD (Dead Peer Detection) and NAT-T (NAT Traversal) are automatically executed in the background for “IPSec Tunneling” when supported by the destination. The IPSec client uses DPD to check, in regular intervals, whether the other side is still active. If the other side is inactive, then an automatic connection-disconnect occurs. Using NAT Traversal is automatic with the IPSec client and is always necessary if network address translation is used on the side of the destination system device.

### ■ Basic configurations depending on the IPsec gateway

The configuration possibilities that you must be aware of depending on whether the Ipsec gateway supports Extended Authentication (XAUTH) and IKE config mode or not, are listed below.

#### *Gateway does not support XAUTH*

As initiator, the IPSec Client always suggests Extended Authentication as standard. This property cannot be configured. If the gateway does not support Extended Authentication, then it will not be executed.

#### *Gateway supports IKE config mode*

If the gateway supports the IKE config mode, the function “Use IKE Config Mode” in the parameter field “IP Address Assignment” could be activated.

#### *Gateway does not support IKE config mode*

If the gateway does not support the IKE config mode, then two configurations are possible.

1. The IP address is defined as “Manual IP address” (see →Profile Settings, IP Address Assignment), the IP address must be entered which has been specified by the gateway or by the administrator.
2. The function “Use local IP address” (see →Profile Settings, IP Address Assignment) causes the private IP address to be set equal to the public IP address, that the client gets per each Internet session from the provider, or if under the “LAN” connection type, the address that the LAN adapter has.

If the “private IP address” has been set and the ”Type” is set to “IP address” in the parameter folder “Identities”, then there is no need to enter an IP address in the field for the “ID”. This is the only way to ensure that each current public IP address will be transferred to the gateway automatically for phase 1 identification.

## 7.2.6 IPsec ports for connection establishment and data traffic

Please note that the server requires exclusive access to UDP port 500. If NAT Traversal is used, then access to port 4500 is also required. Without NAT Traversal the IP protocol ESP (protocol ID 50) is used. Port 500, which is used for connection establishment under Windows systems, is used as standard by the IPsec policies. To change this, proceed as follows:

1. To determine which ports are currently being used by your system, you can enter the following command under the Command Prompt:

```
netstat -n -a
```

to display current network status.

```
C:\>netstat -n -a

Active Connections

Proto Local Address           Foreign Address         State
TCP   0.0.0.0:135              0.0.0.0:0               LISTENING
TCP   0.0.0.0:445              0.0.0.0:0               LISTENING
TCP   0.0.0.0:1025             0.0.0.0:0               LISTENING
TCP   0.0.0.0:1026             0.0.0.0:0               LISTENING
TCP   0.0.0.0:1029             0.0.0.0:0               LISTENING
TCP   0.0.0.0:3372             0.0.0.0:0               LISTENING
TCP   0.0.0.0:20111            0.0.0.0:0               LISTENING
TCP   172.16.109.129:139      0.0.0.0:0               LISTENING
TCP   172.16.111.12:139      0.0.0.0:0               LISTENING
TCP   172.16.111.12:20111    172.16.109.35:1056     ESTABLISHED
UDP   0.0.0.0:135              *:*:
UDP   0.0.0.0:161              *:*:
UDP   0.0.0.0:445              *:*:
UDP   0.0.0.0:500              *:*:
UDP   0.0.0.0:1027             *:*:
UDP   0.0.0.0:1701             *:*:
UDP   0.0.0.0:4500             *:*:
UDP   0.0.0.0:10218            *:*:
UDP   0.0.0.0:10520            *:*:
UDP   0.0.0.0:10522            *:*:
UDP   0.0.0.0:10525            *:*:
UDP   0.0.0.0:10530            *:*:
UDP   0.0.0.0:10590            *:*:
UDP   0.0.0.0:10600            *:*
```

2. If the port is used, then the “System / Services - Administration” window must be opened in the Windows Start menu. The “IPsec policy agent” is highlighted in this window, the service stops and the “Autostart type” is set to “Manual”.

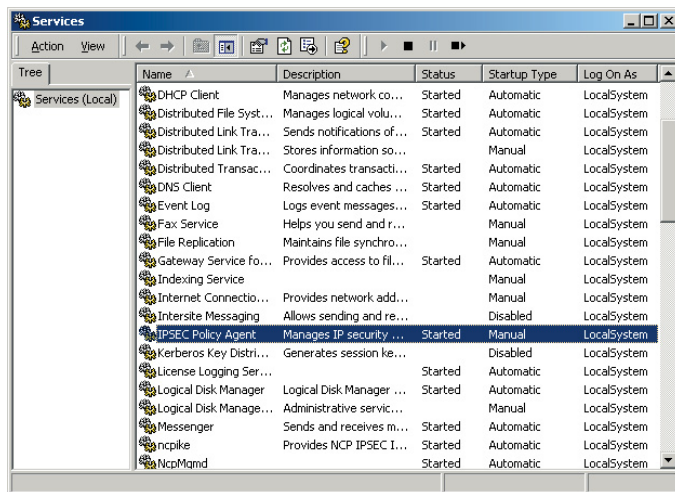

3. If the Autostart type change has been executed, then the command:

```
netstat -n -a
```

can be executed again. In this case UDP port 500 should no longer be listed under the active connections.

## 7.3 Certificate Checks

In addition to the certificate verification according to content a certificate check is executed on the Secure Client in many respects.

### 7.3.1 Selection of the CA Certificates

The corporate network administrator specifies which issuers of certificates can be trusted. This is done by copying the CA certificates of his choice into the `\ncple\ca-certs\ Windows` directory. The copying over can be automated with diskettes in a software distribution, if the issuer certificates are located in the root directory of the first diskette at the installation. Afterwards issuer certificates can be automatically distributed via the Secure Update Server (see → Update Server Manual), or if the user has the requisite write authorizations in the designated directory – they can be set by the user himself (see → Display CA Certificates).

The formats \*.pem and \*.crt are supported for issuer certificates. They can be viewed in the monitor under the menu item “Connection – Certificates – Display CA Certificates”.

If the issuer certificate of another side is received, then the NCP Secure Client determines the issuer, then searches the issuer certificate, first on Smart Card or PKCS#12, and then in the `NCPLE\CACERTS\` directory. If the issuer certificate cannot be found, then the connection cannot be established. If no issuer certificates are present, then no connection will be permitted.

### 7.3.2 Check of Certificate Extensions

Certificates can experience extensions. These serve for the linking of additional attributes with users or public keys, that are required for the administration and operation of the certification hierarchy and the revocation lists. In principle, certificates can contain any number of extensions, including those that are privately defined. The certificate extensions are written in the certificate by the issuing certificate authority.

Three extensions are significant for the Secure Client and the Secure Server:

- extendedKeyUsage
- subjectKeyIdentifier
- authorityKeyIdentifier



## ■ **extendedKeyUsage**

If the `extendedKeyUsage` extension is present in an incoming user certificate, then the Secure Client checks whether the defined extended application intent is “SSL Server Authentication”. If the incoming certificate is not intended for server authentication, then the connection will be refused. If this extension is not present in the certificate, then this will be ignored.

Please note that the SSL server authentication is direction-dependent. This means that the initiator of the tunnel establishment checks the incoming certificate of the other side, if the `extendedKeyUsage` extension is present, then the intended purpose must contain “SSL Server Authentication”. This applies as well for callback to the Client via VPN.

Exception: For a server call-back to the client after a direct dial-up, without VPN but with PKI, the server checks the client certificate for the `extendedKeyUsage` extension. If this is present, then the intended purpose “SSL Server Authentication” must be contained otherwise the connection will be rejected. If this extension is not present in the certificate, then this will be ignored.

## ■ **subjectKeyIdentifier / authorityKeyIdentifier**

A key identifier is an additional ID (hash value) to the CA name on a certificate. The `authoritykeyidentifier` (SHA1 hash over the issuer’s public key) on the incoming certificate must agree with the `subjectKeyIdentifier` (SHA1 hash over the public key of the owner) on the corresponding CA certificate. If no CA certificate is found then the connection is rejected.

The `keyidentifier` designates the public key of the certification authority and thus not only one, but a series of certificates if required. The use of the key identifier allows a greater flexibility for the determining a certificate path.

In addition, the certificates that possess the `authoritykeyidentifier` extension do not need to be revoked if the CA issues a new certificate when the key remains the same.

### 7.8.3 Checking Revocation Lists

The Secure Server can be provided with the associated CRL (Certificate Revocation List) for each issuer certificate. It will be copied into the `\ncple\crls\` Windows directory. If a CRL is present, then the Secure Client checks the incoming certificates to see if they are listed in the CRL. The same applies for an ARL (Authority Revocation List) that must be copied into the `\ncple\arls\` Windows directory.

If incoming certificates are contained in the CRL or ARL lists, then the connection is not permitted. If CRLs or ARLs are not present, then no check takes place in this regard.

## 7.4 Stateful Inspection Technology for the Firewall- Settings

The Stateful Inspection firewall technology can be used for all network adapters as well as for RAS connections. It is activated on the client in the telephone book under “Firewall settings” (see →Configuration parameters, Firewall settings). It is then active on the gateway if the “Protect LAN adapter” function has been switched on in the Server Manager under “Routing interfaces – General”.

The fundamental task of a firewall is to prevent hazards from other networks or external networks (Internet), from spreading in your own network. This is why a firewall is also installed at the junction between corporate network and the Internet, for instance. It checks all incoming and outgoing data packets and decides whether a data packet will be allowed through, or not, based on previously specified configurations.

Stateful Inspection is the Firewall technology that currently offers the highest possible security for Internet connections, and thus for the corporate network. Security is assured in two aspects. On one hand this functionality prevents unauthorized access to data and resources in the central data network. On the other hand, it monitors the status of all existing Internet connections as control instance. Furthermore the Stateful Inspection firewall recognizes whether a connection has opened “spawned connections” – as is the case for instance with FTP or Netmeeting – whose packets likewise must be forwarded. The Stateful Inspection Internet connection appears as a direct line to the communication partner, which may only be used for a data transfer according to the agreed upon rules. Alternative designations for Stateful Inspection are: Stateful Packet Filter, Dynamic Packet Filter, Smart Filtering, and Adaptive Screening.

Stateful Inspection conceptually unifies the protective possibilities of packet filter and application level gateways; this means it integrates the functions of both security processes as a hybrid and works on the network layer as well as on the user layer. With “condition-dependent packet filtering” not only are the Internet and transport layer taken into consideration, but the dependencies from the state of a connection are also taken into consideration. All current and initiated connections are stored with address and allocated port in a dynamic connection table. The Stateful Inspection filter decides which packets belong to which connection based on a specified raster (information). States can be: connection establishment, transfer, or connection disconnect, and they apply for TCP as well as for UDP connections. An example using a Telnet session: The state “Connection establishment” is defined in that user authentication has yet taken place. If the user has logged in with user name and password, then this connection is set to the “normal connection” state. Because the respective state of a connection is constantly monitored, access to the internal corporate network remains denied to unauthorized parties.

The advantage relative to static packet filters is that the decision whether a Gateway or Client will forward a packet or not, is not based on source address, destination address or ports. The security management also checks the state of the connection to a partner. Only those packets are forwarded that belong to an active connection. Data packets that

cannot be assigned to an established connection are rejected and recorded in the log file. New connections can only be opened according to the configured rules.

In the simplest firewall function, only the incoming and outgoing connections are tested and monitored relative to the protocol (TCP/IP, UDP/IP, ICMP, IPX/SPX), the appropriate ports, and the participating computers. Connections are permitted or blocked depending on a specified system of rules. Further tests (such as content or transferred data) do not take place.

The Stateful Inspection filters are a further development of the dynamic packet filter and offer a more complex logic. The firewall checks whether a connection allowed on the port filter can also be established for the defined purpose.

The following additional information about a connection is also managed:

- Connection identification number
- State of the connection (such as establishment, data transfer, disconnect)
- Source address of the first packet
- Destination address of the first packet
- Interface through which the first packet came
- Interface through which the first packet was sent

Based on this information the filter can decide which subsequent packets belong to which connection. Thus a Stateful Inspection system can also eliminate the UDP problem. This involves the relative ease with which UDP packets can be forged, such as is the case with UDP-based DNS service. Because Stateful Inspection filters can note the current status and context information of a communication relationship, it is necessary that source and destination address as well as source and destination port, and also the DNS header in the query packet be included when saving the status and context information. The system executes an interpretation on the application layer.

Example: An incoming connection to port 21 of a computer is an FTP connection for a pure port filter. An additional test does not take place. On the other hand, the Stateful Inspection filter additionally checks whether the data transferred via this connection belong to an established FTP connection. If not, then the connection will be disconnected immediately. In addition, a Stateful Inspection filter is able to adapt rules depending on necessary communication processes. If, for example, an outgoing FTP connection is allowed, then the firewall also automatically enables the establishment of the associated reverse channel. The corresponding information (ports) is read out of the control connection.

One advantageous aspect of Stateful Inspection filters is the capability to check the data on all protocol layers (this means from the network layer to the application layer). Thus for example an FTP-GET can be allowed, however an FTP-PUT can be prohibited. A positive effect of the increased intelligence relative to conventional packet filters is the option of assembling individual packets during a communication relationship, and thus bring extended possibilities for user authentication to the application. Stateful Inspection filters are not immune to certain attacks that take place on the lower protocol layers as a consequence of the undependable separation of the network seg-

ments. Thus for instance, fragmented packets (usually from outside to inside) will be allowed through without further testing.

*For your notes →*

# Abbreviations and Technical Terms

<b>3DES</b>	TripleDES. Standard of Encryption with 112 Bits.
<b>AES</b>	Abbreviation for Advanced Encryption Standard. It is a European development of Belgian encryption experts Joan Daemen and Vincent Rijmen (“Rijndael algorithm”), and supercedes DES (Data Encryption Standard). This is an encryption algorithm that has key lengths of up to 256 bits. Thus N to the 256th power is the measuring unit for the number of possible keys that can be generated with this algorithm. In spite of increasing processor speeds it is expected that the AES algorithm will offer acceptable security for the next 30 years. AES will soon find wide distribution in VPN and SSL encryptions.
<b>AH</b>	Authentication Header RFC 2402
<b>Analog Interface</b>	This is an interface for connecting analog devices (e.g. modems, facsimile group 3 machines, analog telephones etc.). The current international standard connector for analog devices is RJ11.
<b>Asymmetric Encryption</b>	(Public Key Process) In an asymmetric encryption each participant has two keys: a secret private key and a public key. Both keys stand in a mathematically defined relationship to each other (2 Key Service). The participant’s private key is strictly secret; the public key is available to anyone. Key management is straightforward even with large numbers of participants. For example: Two keys per participant generate a total of 2000 keys to enable secure communication for 1000 participants in all sender-recipient combinations. RSA is the best-known asymmetric encryption process. The disadvantage of the asymmetric encryption process is that it is calculation-intensive and thus comparatively slow.
<b>Basic Connection (So / BRI = Basic Rate Interface)</b>	A type of ISDN connection with So-interface. (“S” stands for subscriber interface: user interface). It

consists of a D-Channel (bandwidth: 16 kBits/s) for controlling and two B-Channels (bandwidth: 64 kBits/s each) for data transmission.

<b>Basic Rate Interface (BRI)</b>	An ISDN subscriber service that uses 2 B-Channels (64 Kbps) and 1 D-Channel (16 Kbps) to transmit data, audio, voice and video signals over a digital dial-up circuit. BRI's are available from your local PTT.
<b>BCP</b>	Bridge Control Protocol
<b>BITS</b>	Bump In The Stack - A type of IPSec implementation.
<b>BITW</b>	Bump In The Wire - A type of IPSec implementation.
<b>Blowfish</b>	Encryption Standard with 128/448 Bit
<b>Browser (Web Browser)</b>	This is the user interface to the Internet. With its HTTP (Hypertext Transfer Protocol) capability it can handle different formats (for example HTML, GIF, CAD) that are required for a multi-media (sound and graphics) representation of the information.
<b>CA (Certification Authority)</b>	Also Trust Center (for example D-trust, a combined undertaking of Debis and the Federal Printing Office). With PKI Manager Software a CA issues digital, signed confirmations (certificates) and stores them on a Smartcard (Chipcard). A CA can be a private service provider or a public institution. These certifying authorities do not need government permission and the private service provider or public institution is liable for the correctness of the certificates.
<b>CAPI</b>	Common Application Program Interface. This interface is designated as a common ISDN API in ISDN and corresponds to the PCI interface (Programmable Communication Interface). The interface direct access to ISDN and the lower protocol layers (Layers 1-3). Higher-level protocols (applications) like telex and file transfer can be used regardless of the hardware platform implemented. There are two versions of CAPI, 1.1 and 2.0. The ISDN applications are programmed accordingly either for CAPI 1.1 or CAPI 2.0, or for the specific CAPI requirements. A hybrid CAPI allows implementation of application software for CAPI 1.1 as well as for CAPI 2.0 (see Hybrid CAPI).

<b>CCP</b>	Compression Control Protocol
<b>Certificates</b>	Certificates are issued by a CA (Certification Authority) with a PKI Manager (software) and stored on a Smartcard. This Smartcard contains digital signatures in addition to the Certificates. These digital signatures are equivalent to a digital personal identity card.
<b>CHAP</b>	Challenge Authentication Protocol
<b>CLI</b>	Calling Line Identification (Caller ID - Euro-ISDN)
<b>COSO</b>	Charge One Side Only. The low level callback is negotiated via D-Channel and uses call waiting via D-Channel. This method is very popular, because as opposed to PPP no local charge is assessed to the caller when dialing-up or connecting to the remote destination. The caller initiates the request for a connection on the ISDN D-Channel. The receiver establishes the connection and is charged.
<b>Cryptography</b>	Applications are encryption, electronic signature, authentication, and Hash Value Calculation. These are mathematical processes that are used with a key.
<b>CTAPI</b>	Interface to Smartcard Readers
<b>CUG</b>	Closed User Group (Euro-ISDN)
<b>DES</b>	Data Encryption Standard
<b>DHCP</b>	Communicating with DHCP (Dynamic Host Control Protocol) means that an IP Address is automatically assigned to you for every session.
<b>Directory Service</b>	Remote Accesses like Email addresses, telephone numbers etc. are stored in directories of various databases. Two problems are associated with this directory multiplicity, they are (1) large volumes of the same data must be captured many times (2) individual entries are not linked to each other. The maintenance required is enormous and inconsistencies cannot be ruled out. A standardized procedure is required that will facilitate the capture and maintenance of all information in a central directory. NCP Security Management supports the stand-



ardized protocols RADIUS (Remote Authorization dial-In User Service), and LDAP (Lightweight Directory Access Protocol). The latter insures access to centralized directory services.

<b>DMZ</b>	Demilitarized Zone - an area between the Firewall and the enterprise network with Web Servers, Email Servers and VPN Servers.
<b>DNS</b>	The Domain Name Server (DNS) makes the IP address available for an Internet session after dial-in with user name and password. It provides additional Internet routing in that it retranslates the given desired destination names into IP addresses and creates the connection to this address.
<b>DNS Server</b>	A computer with a database containing all relevant host computers (domain name addresses) and their corresponding IP addresses. When queried, the DNS Server responds by returning the IP address corresponding to the domain name address.
<b>D-Channel Protocol</b>	The D-Channel insures that terminals can communicate with the network. Among other things it monitors connection setup and breakdown. It includes Layers 2 and 3. HDLC is implemented on Layer 2 in ISDN for the logical data transfer. The actual D-Channel protocol resides on Layer 3. Currently DSS1 is available throughout Europe as D-Channel protocol.
<b>DSA</b>	Directory System Agent
<b>DSS1</b>	Abbreviation for the European standard Digital Subscriber System No.1. This is the European ISDN protocol for D-Channel.
<b>DUA</b>	Directory User Agent
<b>ECP</b>	Encryption Control Protocol
<b>EDI</b>	This is an abbreviation for Electronic Data Interchange, which is a set of standards for controlling the transmission of business documents (e.g. purchase orders and invoices) between computers.
<b>ESP</b>	Encapsulating Security Payload RFC 2406

<b>Euro-ISDN</b>	The International Telecommunications Union (ITU) standard for European ISDN, refers to the D-Channel Protocol DSS1 as well as various service features (e.g. Time & Charges, Completion of Calls to Busy Subscriber, Call Forwarding, Call Waiting, etc.). In Euro-ISDN the individual terminals are addressed with the D-Channel protocol DSS1 with the multiple subscriber number (MSN).
<b>Firewall</b>	A division between public network and private network. It is a protection mechanism that regulates the station access. A firewall computer seals off a network from unauthorized access, particularly from the WAN side. For example, authorization of incoming and outgoing connections is regulated by filtering out certain network participants and network services and by determining access rights. From the WAN perspective it is usually web servers, Email servers, and VPN servers that are located behind the firewall in the DMZ.
<b>FTP</b>	File Transfer Protocol. Based on TCP and TELNET (Port 21).
<b>FTP Server</b>	A fileserver that supports the File Transfer Protocol enabling users to download or upload files through the Internet or any other TCP/IP Network.
<b>GPRS</b>	Standard for fast handy communication
<b>GRE</b>	Generic Router Encapsulation. CISO specific tunneling protocol.
<b>GSM</b>	Global System Mobile. Standard for cellular communications
<b>Hash Value</b>	see Signature
<b>HBCI</b>	Standard for Smartcard Readers (Online Banking)
<b>HTTP</b>	Hypertext Transfer Protocol. (Port 80)
<b>Hybrid Encryption</b>	High performance and high security: Hybrid encryption combines the advantages of symmetric and asymmetric processes. While communication content is secured with fast symmetric algorithms, participant authentication and key exchange occur on the basis of asymmetric processes. Actual document data encryption is determined by a random

number (session key) that is generated for each individual communication connection. This one-time key is encrypted with the recipient's public key and the message is added. Then the recipient reconstructs the session key with his private key and decrypts the message.

<b>IETF</b>	Internet Engineering Task Force.
<b>IKE</b>	Internet Key Exchange, which is part of IPsec for secure key management, separate security association negotiation, and key management protocol RFC 2409.
<b>Internet</b>	The Internet is a worldwide open computer network. It is open to all. Every company and each individual can connect to the Internet and can communicate with all other connected users regardless of the computer platform or the respective network topology. A general shared network protocol is necessary to insure that data exchange between the different computers and networks is possible (see TCP/IP).
<b>Intranet</b>	A network within a company or organization employing applications associated with the Internet, such as Web pages, Web browsers, FTP Sites, E Mail, etc. However these are only accessible to those within the company or organization.
<b>IP Address</b>	Each computer in the Internet has an IP address (Internet Protocol Address) that clearly identifies it for as long as it is part of the Internet. An IP address is 32 bits long and consists of four numbers separated from each other by a dot. There are 8 bits available for each number thus it can take on 256 values. However the total number of possible IP addresses remains limited. The internet user thus does not receive a one-time non-modifiable number assigned to him, rather for every one of his sessions he gets the IP address that has not yet been assigned. The IP addresses are assigned for the duration of a time slice. This assignment of address is usually an automatic PPP negotiation over DHCP. Special programs can translate the IP address into a name. These programs run on a Domain Server.

<b>IP Network Address Translation</b>	IP Network Address translation is already setup when the workstation software is installed and it is activated as default when a new destination system is created! When IP network address translation is used all transmitted frames are sent with the negotiated (PPP) IP address. The workstation software translates this official IP address into the system's own Internet address, or in the case of a workstation, into its own user defined IP address. In general it is possible with NAT to work in a LAN with unofficial IP addresses that are not valid in the Internet and, in spite of that fact, access the Internet from the LAN. To make this possible the unofficial IP addresses are translated into official IP addresses by the software. This saves official Internet addresses, that are not available in unlimited numbers on the one hand, and on the other hand NAT establishes a certain protection (Firewall) for the LAN.
<b>IPCP</b>	Internet Protocol Control Protocol
<b>IPsec</b>	IETF Standards: RFC's 2401-2412 (12/98)
<b>IPX</b>	Internet Packet Exchange, Netware protocol from Novell
<b>IPXCP</b>	Internetwork Packet Exchange Control Protocol
<b>ISDN</b>	Integrated Services Digital Network. A digital network that integrates all narrow band communication services (for example telephone, telex, fax, teletext, videotext) consisting of channels with a transfer speed 64.000 bit/s. A basic connection in the so-called narrow band ISDN has three transmission channels: channel B1 64,000 bits/ s, B2 64,000 bits/s, D-Channel 16,000 bits/s. The total transmission rate is 144,000 bits/s. By the end of the millennium this network should be uniformly extended throughout Europe. The specifications for ISDN are worked out by ITU and CEPT.
<b>ISDN Adapter</b>	The products of the NCP Arrow family are ISDN adapters. They make it possible to connect existing non-ISDN capable terminals to the ISDN network. The adapter handles the software and the hardware adaptation of the terminal interface to the ISDN interface (So). An ISDN adapter with Upo terminal interface enables the conversion of ISDN two wire

interface Upo (range 3.5 km) on bus-capable ISDN  
4 wire interface So (range 150 m) with ISDN TK  
equipment in accordance with Telekom Guideli-  
nes.

<b>ISP</b>	Internet Service Provider
<b>ISO/OSI Reference Model</b>	The ISO standardized model that describes communication in 7 layers (7. Application Layer, 6. Presentation Layer, 5. Session Layer, 4. Transport Layer, 3. Network Layer, 2. Data Link Layer, 1. Physical Layer). Data transmitted in a network are processed consecutively 7 -1 as above. The order is reversed on the receiver side.
<b>L2F</b>	Tunnel / VPN protocol Layer 2 Forwarding
<b>L2TP</b>	Tunnel / VPN protocol Layer 2 Tunneling Protocol
<b>L2Sec</b>	NCP designation, functional description in RFC 2716
<b>LCP</b>	Link Control Protocol
<b>LDAP</b>	Lightweight Directory Access Protocol (see Directory Service)
<b>MAC Address</b>	This stands for Medium Access Control Layer Address. It is a physical address in the network.
<b>MIB</b>	Management Information Base
<b>MD5</b>	Message Digit 5. Used to generate a hash value.
<b>Name</b>	Exact Internet name, it is supposed to make it easier for the users to work on the Internet. The names are entered in the Internet browser and are then translated into IP addresses by the Domain Server.
<b>NAS</b>	Network Access System
<b>NetBios</b>	Network Basic Input Output System an interface that offers datagram and stream-oriented communication.
<b>OCSP</b>	Abbreviation for Online Certificate Status Protocol. It is a protocol used for online verification of certificates.

<b>PAP</b>	PAP Password Authentication Protocol. Security mechanism inside the PP for authenticating the other side. PAP defines a method according to which the establishment of a connection whereby the rights of the sender are checked based on a user name and password. In this process the password is sent over the line in clear text. The recipient compares the parameters with his own data and if in agreement releases the connection.
<b>PBX</b>	An abbreviation for Private Branch Exchange, which is an automatic telephone switching system that enables users within a company to place calls to each other without having to go through the public telephone network. Users of course can also make calls and receive calls from the public telephone network.
<b>PC/SC</b>	Interface to Smartcard readers
<b>PEM</b>	An older form of Soft Certificates (without private key).
<b>Personal Firewall</b>	Client software security mechanisms combine tunneling processes and personal Firewalling, IP Network Address Translation (IP-NAT), as well as universal filter mechanisms. IP Nat is of central importance then it ensures that only outgoing connections from the computer to the Internet are possible. Incoming data packets are checked on the basis of refined filtering for precisely defined characteristics and are discarded if there is no agreement. This means that the Internet port of the respective computer is completely camouflaged and the establishment of undesired connections is impossible.
<b>PIN</b>	Personal Identification Number
<b>PKCS</b>	Abbreviation for Public Key Cryptography System, an encryption system with public key.
<b>PKCS#10</b>	A method defining how a certificate is transferred from the PKI manager to the CA (Certification Authority). Usually via Http - encrypted with SSL as Https.
<b>PKCS#11</b>	Basis for Smartcard standards

<b>PKCS#12</b>	Soft certificate. A standard that describes the data structure syntax.
<b>PKCS#15</b>	Smartcard pointer description. Indicates where what will be found on the Smartcard
<b>PKI</b>	This is used for Key Management. Transaction-based security requires a clear partner authentication by means of certificates that have been issued by a trustworthy PKI. Particularly for E-commerce PKI offers the framework for confidentiality (secrecy), Integrity (counterfeit security), authenticity (identity security) and indisputability.
<b>PoP</b>	Point of Presence
<b>POP3</b>	Protocol, used for downloading Emails. Counterpart to SMTP (Port 10).
<b>PPP</b>	Point-to-Point Protocol. Transmission protocol in connection oriented networks.
<b>PPP negotiation</b>	In a PPP negotiation the IP address is assigned automatically after the logon at the provider.
<b>PRI</b>	Primary Rate Interface. (ISDN interface, primary multiplex S2m with 30 B-Channels and 2 D-Channels.
<b>Radius</b>	Remote Authorization Dial-In User Service, see Directory Service
<b>RA</b>	Registration Authority. For the most part the registering location is the site that accepts the certificate application. The RA is also the site where the loss or deterioration of a valid certificate is reported. It is also the site that issues revocation lists for certificates that have become invalid.
<b>RAS</b>	Remote Access services. Company Specific (Microsoft) dial in help for Remote Access Routing Information Protocol, also routing mode.
<b>Revocation list</b>	The revocation list includes client certificates that have been revoked or blacklisted. When a user for example notifies the CA that their Smartcard has been stolen, the certificate will be revoked by the CA and entered in the Revocation List. Certificates that expire will not be listed in a revocation list. Revocation Lists are regularly updated.

<b>RIP</b>	Routing Information Protocol, also Routing Mode
<b>RFC</b>	Request for Comment. Blueprint for a standard or a pre-standard that is in discussion and will be kept in the list of RFC's as long as it proves itself in practice. Earlier forms of RFC's are drafts.
<b>Routing Tables</b>	Routers require information about the best routes from the source to the destination for route selection in the network. With the routing table's help these segments are calculated. With static routing the tables have been firmly defined. In dynamic routing the router receives information about the network through router information protocols (for example RIP, NLSP, OSPF) that is collected and continuously updated in self-learning router tables.
<b>RSA</b>	The first procedure that fulfilled the demands for public key cryptographics. Invented 1977 by Ron Rivest, Adi Shamier and Leonard Adleman.
<b>SHA</b>	Secure Hash Algorithm, see also Signature
<b>Signature</b>	A digital signature requires the generation of a mathematical link between document and the secret personal signature key of the participant. The document sender generates a checksum or so-called Hash Value, this he in turn codifies with his secret key and thus creates a digital signature addition to the original document. The document recipient can check the signature with the sender's public key by constructing on his side the Hash value from the message and comparing it to the encrypted signature. Because the sender's signature is directly bound into the document every later modification would be noticed. Also interception or eavesdropping of the signature through data interception is to no avail. The digital signature cannot be emulated or copied because it uses the secret key. It is impossible to determine the secret key from the signature.
<b>Smartcard</b>	If you use the functionality of the Smartcard after CHAP Authentication (User ID and Password) then the Strong Authentication with the stored certificates on the Smartcard and the Gateway will be executed. Among other things the user certificate,



the root certificate, and the secret private key, are stored on the Smartcard. The Smartcard can only be used with a valid PIN.

<b>SMTP</b>	Simple Mail Transport Protocol. Internet standard to distribute Email. Based on TCP (Port 25). It is text oriented.
<b>SNA</b>	Systems Network Architecture. Hierarchically oriented network for the control of terminals and for application access support in IBM host systems.
<b>SNMP</b>	Simple Network Management Protocol. Network management protocol based on UDP/IP.
<b>Source Routing</b>	The possibility to optimize route selection between bridges in Token-Ring networks. With SNA, route information hanging on the datablock is also transmitted. In this manner the confirmation route is also clearly manifest.
<b>SPD</b>	Security Policy Database
<b>SSL</b>	Secure Socket Layer. According to the SSL protocol Dynamic Key Exchange can be used. SSL, developed by Netscape, in the meantime has become the standard protocol for Dynamic Key Exchange
<b>SSLCP</b>	Secure Socket Layer Control Protocol
<b>STARCOS</b>	Operating system for Smartcards
<b>Symmetric Encryption</b>	Sender and recipient use the same key for symmetric encryption and decryption. Symmetric algorithms are very fast and very secure - only if the key transfer between the sender and the recipient is not endangered. If an unauthorized person is in possession of the key then this person can decrypt all messages. In other words using the key he will appear as the message sender. If for larger groups of participants symmetric encryption is to be used so that each participant can only read messages addressed to him, then an individual key is required for each sender-recipient pair. This results in a somewhat cumbersome key management. For example, for 1000 participants 499,500 different keys are necessary (!) to support all possible relationships. Currently the best-known symmetric encryption is the DES algorithm.

<b>TCP/IP</b>	An abbreviation for Transfer Control Protocol / Internet Protocol, which is a network protocol used by computers to communicate with each other. TCP/IP can be used in most any LAN or WAN, regardless of the underlying topology (Token Ring, Ethernet, X.25, ISDN, Frame Relay etc.). TCP/IP also includes various Internet standards: FTP: File Transfer Protocol (for File Transfer) / SMTP: Simple Mail Transport Protocol (for E Mail) / TELNET: Teletype Network (for Terminal Emulation) / RLOGIN: Remote Login (for remote control purposes)
<b>TECOS</b>	Operating system for Smartcards (V. 1.2, 2.0)
<b>Token Ring</b>	Ring structure network topology from IBM.
<b>UDP</b>	User Data Protocol. This builds directly on the underlying Internet protocol. It was defined to also provide application processes with the direct possibility to send datagrams. UDP delivers over and above the capabilities of TCP/IP simply a port number and checksum of the data. Due to the lack of overhead such as receipts and security mechanisms it is particularly fast and efficient.
<b>UMTS</b>	Universal Mobile Telecommunications Service. Future Standard for fast mobile phone communication.
<b>VPN</b>	Virtual Private Network. A VPN can be implemented as a virtual network over all IP carrier networks - that means the Internet as well. Two specifications have crystallized for the realization of a VPN: L2F (Layer 2 Tunneling) and L2TP (Layer 2 Tunneling Protocol) both processes serve to establish a tunnel that can be considered a "virtual leased line". In addition to IP frames also IPX data, SNA data, and NetBios data are transparently transmitted over such a logical connection. At the end of the tunnel the data packets must be interpreted and transformed into a DataStream on the basis of the protocol used.
<b>WAN</b>	Abbreviation for Wide Area Network, which is a communications network that connects networks that are separated geographically. (normally LAN = Local Area Network). WANs are normally pro-

vided by PTTs or Carriers and generally speaking offer high speed connection (64 Kbps - 2 Mbps or higher).

**WAP**

Wireless Application Protocol. Developed by Nokia, Ericsson and Motorola.

**WINS**

An abbreviation for Windows Internet Naming Service, which is a Windows NT Server method for linking a computer's host name to its address. This was the original Microsoft derivative of DNS, and is also referred to as INS = Internet Naming Service.

**X.25**

An ITU (International Telecommunications Union) recommendation that specifies the connection between an end device (e.g. PC or terminal) and a packet switched network. X.25 and is based on three definitions. (1) the physical connection between the end device and the network, (2) the transmission access protocol, and (3) the implementation of virtual circuits between network users. Together, these definitions specify a synchronous, full duplex end device (terminal) to network connection.

**X.509 v3**

A Standard of Certification

Appendix to the  
NCP Secure Enterprise Client and NCP Secure Entry Client:

## Mobile Computing via GPRS/UMTS and Domain Login via NCP Gina



Network  
Communications  
Products engineering GmbH

GERMANY  
Headquarters  
Dombühler Str.2  
D-90449 Nürnberg  
Tel.: +49-911-9968-0  
Fax: +49-911-9968-299  
internet [http:// www.ncp.de](http://www.ncp.de)  
E-mail: [info@ncp.de](mailto:info@ncp.de)

# Contents

<b>1. Mobile Computing via “GPRS/UMTS”</b> . . . . .	<b>A5</b>
1.1 Installation . . . . .	A6
1.2 Driver Installation . . . . .	A6
<b>2. Configuring a Destination System (Profiles)</b> . . . . .	<b>A8</b>
2.1 Configuring with a Wizard . . . . .	A8
2.2 Configuration in the Phonebook . . . . .	A12
<b>3. The Monitor</b> . . . . .	<b>A14</b>
<b>4. Domain Login via NCP Gina</b> . . . . .	<b>A17</b>
4.1 Logon Options . . . . .	A19
<b>5. Log Files</b> . . . . .	<b>A21</b>



*For your notes →*

# 1. Mobile Computing via “GPRS/UMTS”

If you are using a multi-function card\* for UMTS/GPRS/WLAN, then with the NCP Client software\*\*, special features of the mobile computing can be used depending on the card characteristics.

Due to the direct support of the multi-function card for UMTS/GPRS/WLAN through the Secure Client, installation of management software from the card implemented, is not necessary.

The NCP Secure Client combines all communication and technical security mechanisms for economic data communication on the basis of the end-to-end principle of security. The Client Monitor has visual displays of all connection states, field strength, the selected network, and the provider. Also the integrated dynamic Personal Firewall is optimized for remote access and protects the mobile teleworkstation (even at system start) against any attacks and guarantees maximum security, also during the automatic hotspot login. The VPN connection is established via the integrated NCP Dialer independent of the Microsoft data communications network.

\* Currently supported multi-function cards:

T-Mobile Multimedia NetCard  
Vodafone Mobile Connect Card  
KPN Mobile Connect Card

\*\* Alternative versions of the NCP Client Software:

Enterprise Client from version 8.10 SP1  
Entry Client from Version 8.21



## 1.1 Installation

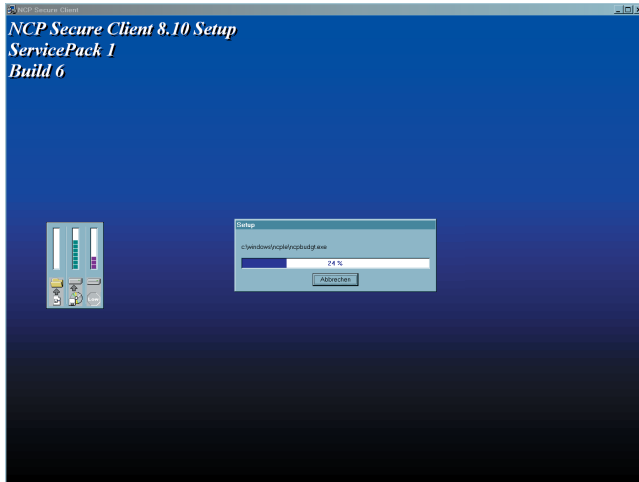

First install the appropriate software version and then install the PCMCIA card driver on your notebook.

## 1.2 Driver Installation

The driver for the Qualcomm 3G CDMA PCMCIA card is on the included CD in the directory

`Software\Modems\Language Independent\`

Start “OptionFusion.exe” with a double click and confirm the query that is displayed with “OK”.

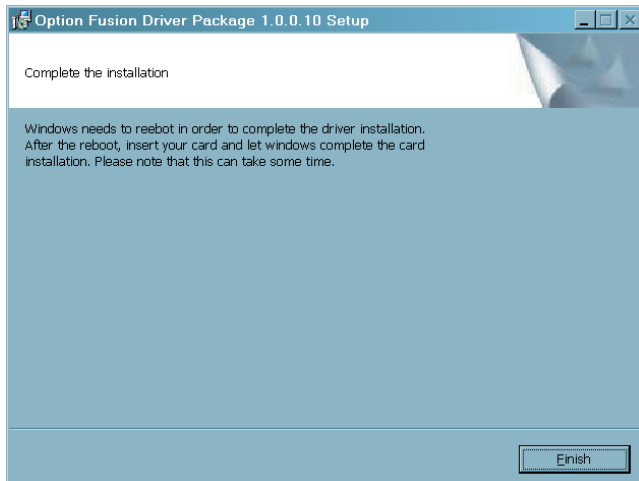

After completing the installation end setup by clicking on “Finish”.

Then the computer will reboot.

After the reboot insert the card in a PCMCIA slot.

**Please note the following if using the Windows XP operating system**

If Windows XP is used with Service Pack 2 and security packages, then a connection cannot be established via the card.

The software will display an error message when attempting to establish a connection (see Fig. to the left).

In this case a new driver must be installed. The file OptionCardInstaller.exe is available from NCP for this purpose.

A newer driver is on the driver CD for the newer Multimedia NetCard from T-Mobile, which only supports UMTS/GPRS.

## 2. Configuring a Destination System (Profiles)

Create a new destination system (profile) in the NCP Client software. Follow the instructions provided in the Client Software Manual.

### 2.1 Configuring with a Wizard

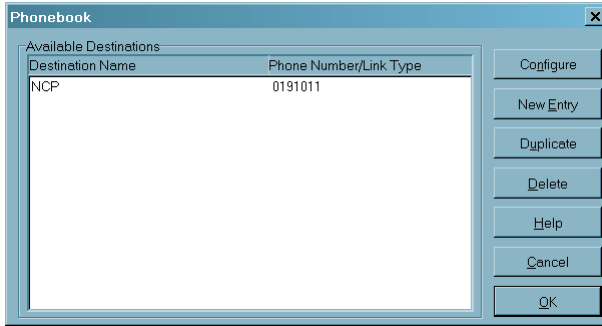

Click on “New entry” and follow the wizard’s instructions. Afterwards you can complete the configuration in the telephone book.

A connection to the corporate network is provided below as an example.

An NCP Gateway is used as the destination system for this test connection.

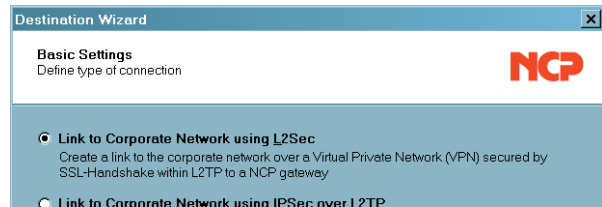

Click on “Next”

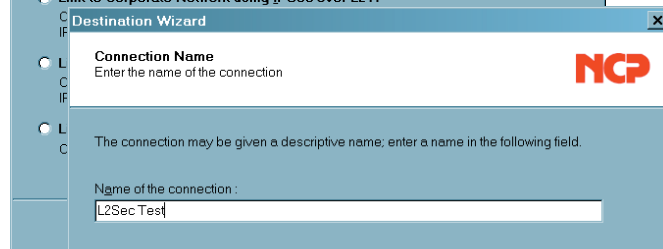

Enter a name for this destination system (profile).

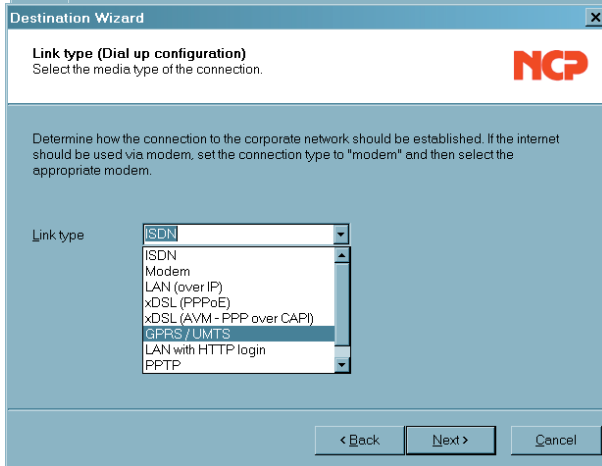

Click on “Next”

Select GPRS/UMTS as connection type.

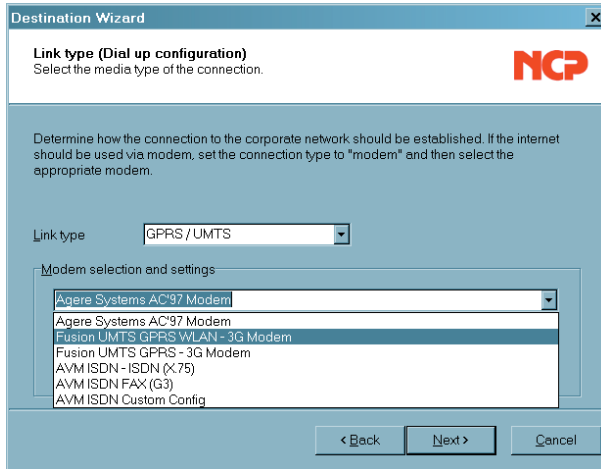

The card "Fusion UMTS GPRS WLAN - 3G modem" will be displayed accordingly. Select this card.

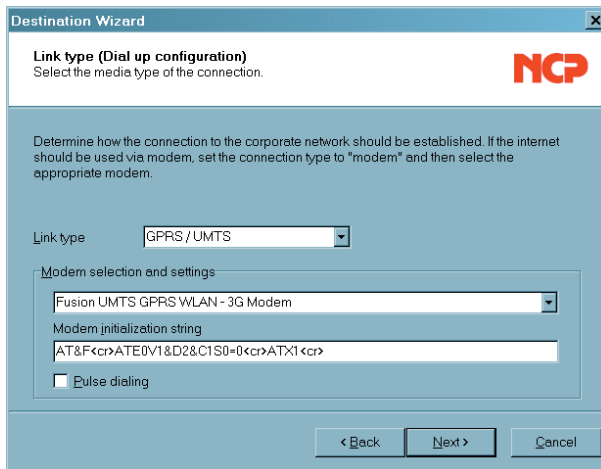

Do not make any changes to the modem initialization string. Do not switch pulse dialing on.

Click on "Next"

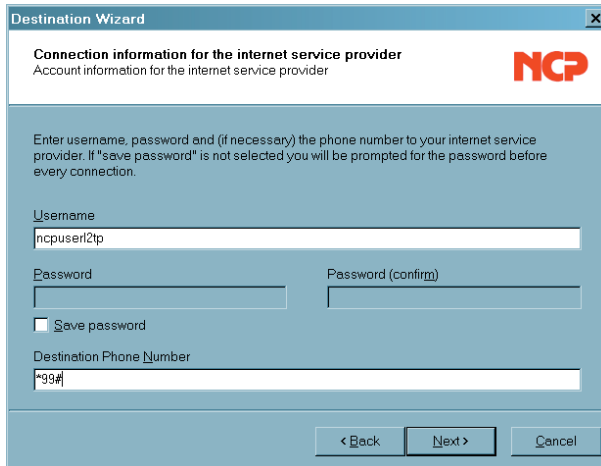

You only need to enter a (any) user name for the Internet Service Provider (ISP) unless you have received special passwords from the provider. Billing (and the identification) is executed via the SIM card.

For a test connection to an NCP Gateway enter as telephone number:  
\* 9 9 #

Click on "Next"

Read the description of the gateway parameters.

If you want to setup a test connection to the NCP Gateway then enter as tunnel endpoint:

62.153.165.36

as tunnel secret:

secret

Compression is not necessary.

Click on “Next”

You do not need a certificate for a test connection to the NCP Gateway.

Click on “Next”

Enter the following as access data for the NCP VPN Gateway:

VPN User ID:

ncpuser12tp

Click on “Save VPN Password”

and enter the following as VPN password:

ncpuser12tp

Click on “Next”

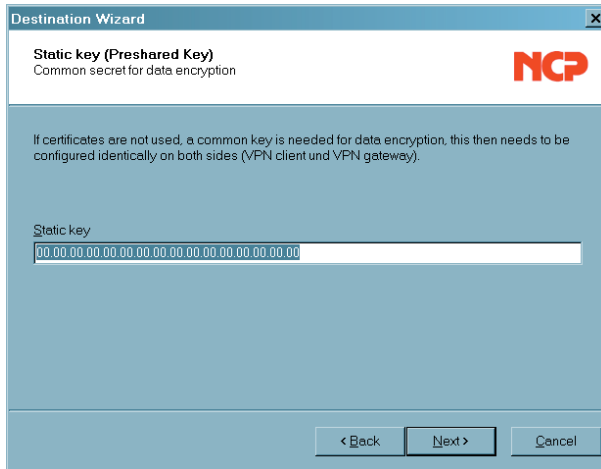

Do not change the static key setting for the test connection.

Click on "Next"

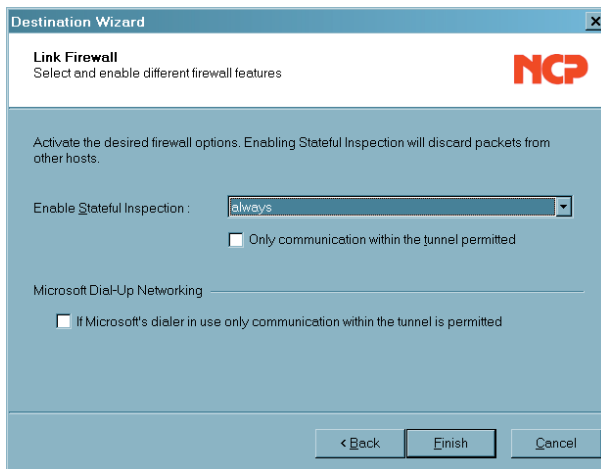

It is not necessary to set the Link Firewall for the test connection.

Click on "Next"

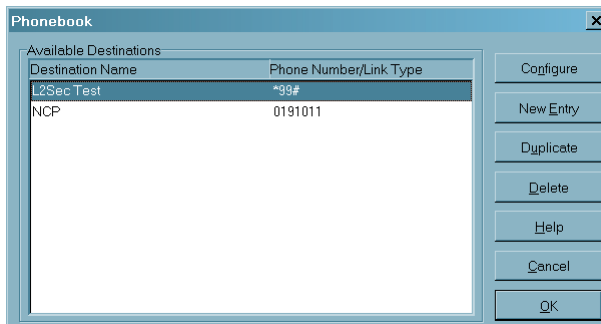

This concludes the configuration with the assistant.

Now click on "Configuration" and complete the configuration in the telephone book.

## 2.2 Configuration in the Phonebook

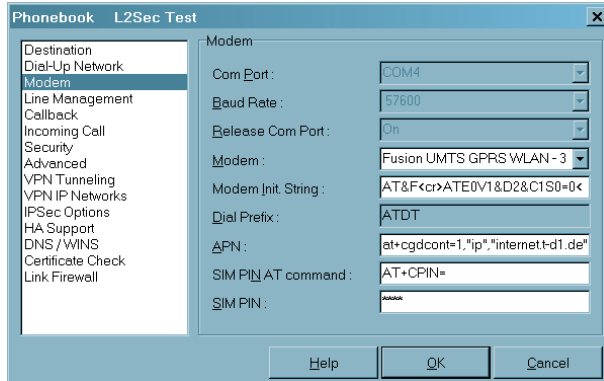

For the test connection select the parameter “Modem” and make the following entries:

### APN

The APN (Access Point Name) is required for the GPRS and UMTS dial-in. You get the APN from your provider. The APN is used primarily for administrative purposes.

The AT command `at+cgdconf=1,"ip",` is standard for the transferring the APN to the SIM card, however it can vary depending on the provider.

The APN `"internet.t-d1.de"` varies depending on the SIM card and only applies for the SIM D1 card from T-Mobile.

### SIM PIN AT command

When using a GPRS/UMTS card the specific AT command must be entered. This command `AT+CPIN=` is standard and causes the SIM PIN to be correctly detected.

### SIM PIN

If you are using a SIM card for GPRS or UMTS then enter the PIN for this card here. If you are using a mobile phone, then this PIN must be entered on the mobile phone.

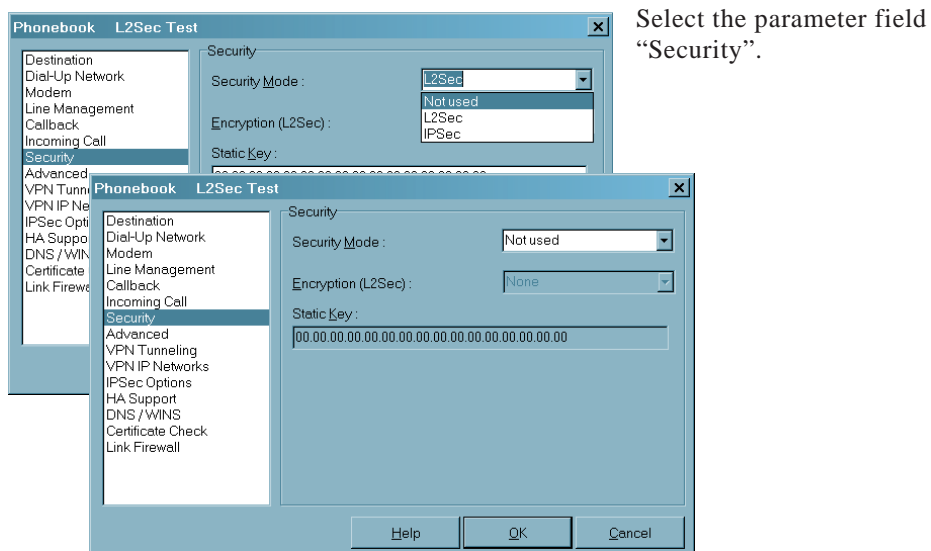

### Security Mode

Do not use security mode for the test connection!

Select "Do not use" and then click on "OK".

Save the telephone book setting and then open the Monitor.



### 3. The Monitor

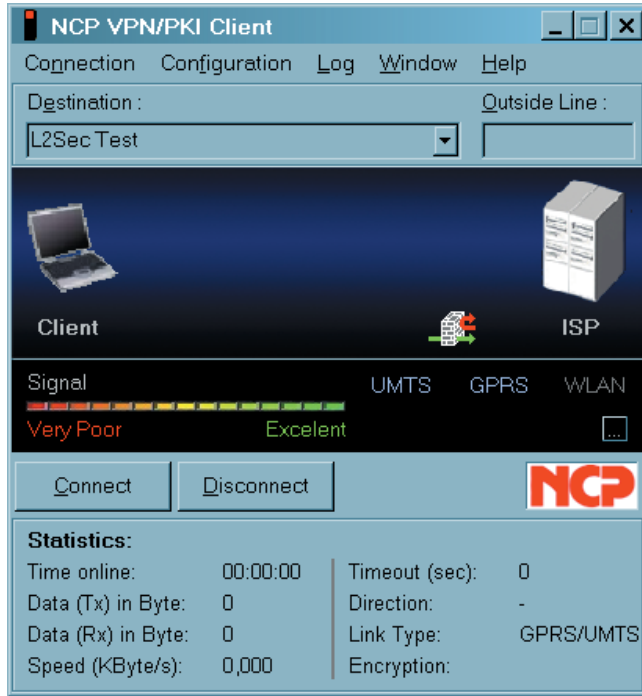

Start the Monitor.

The Monitor of the VPN/PKI client (Enterprise Client) must look like the adjacent illustration. The Entry Client Monitor is essentially the same.

The field strength of the wireless network must be displayed between the graphic field and the toolbar.



If the field strength is not displayed, then an error message will appear which refers to a modem error. In this case proceed as described under “1.1 Driver installation”.

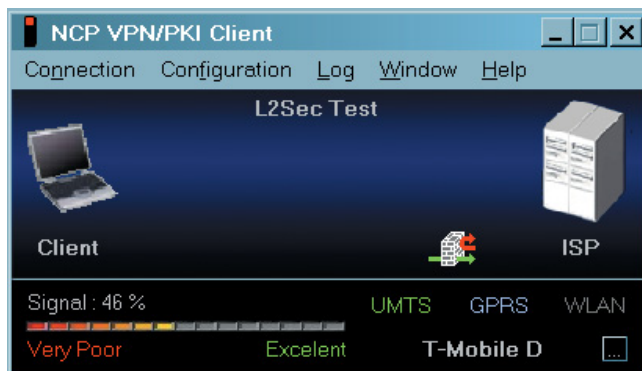

After the Monitor starts the card will automatically search for a wireless network and displays it with the corresponding field strength, once a wireless network has been found (T-Mobile D" in the fig. to the left).

If the network is displayed, then another network search can be triggered by clicking on the [...] button.

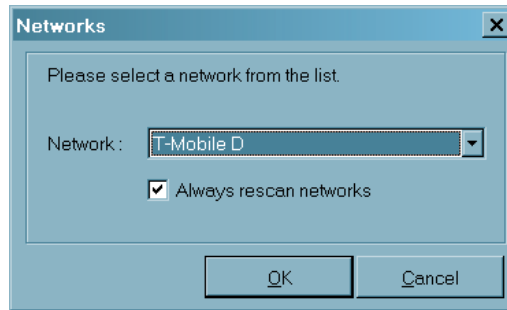

After searching for an alternative network the window for network selection will be displayed. The desired network can be selected from a list.

If a new network search is not desired every time the Monitor is called up, then this function (which is active by default) must be switched off via the Check button.

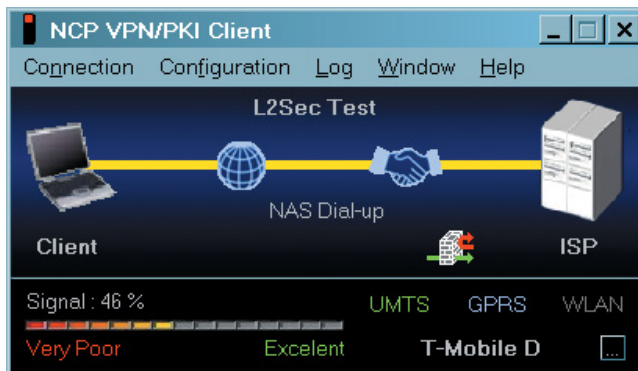

The connection set-up can be executed precisely in the same manner as for a stationary network (see “Connection setup” in the Client Software Manual), alternatively the connection can be setup with the modes “automatic”, “manual” or “alternating”.

The connection type is displayed in green (“UMTS” to the left).

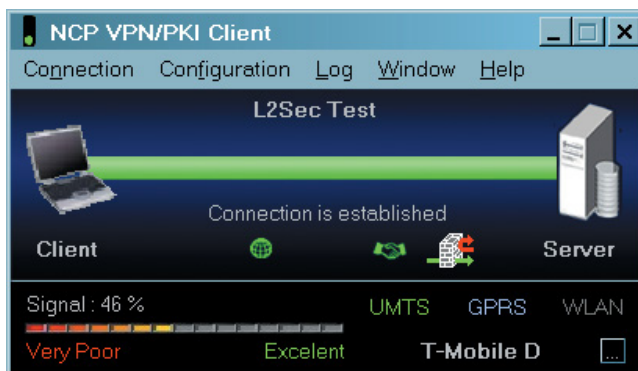

Once the connection is set-up, then you can work in the same manner you work in your local corporate network.

This also applies if the card automatically changes from the connection medium UMTS to GPRS due to low field strength. In this case the connection remains intact.

If the field strength increases again, then the card automatic switches back.

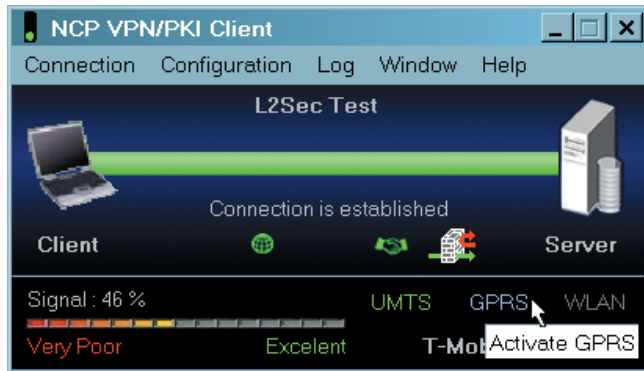

You can also change the connection medium manually. Click on the desired medium with the mouse, in the Fig. to the left, "Activate GPRS".

However if you change the medium manually the connection will be disconnected.

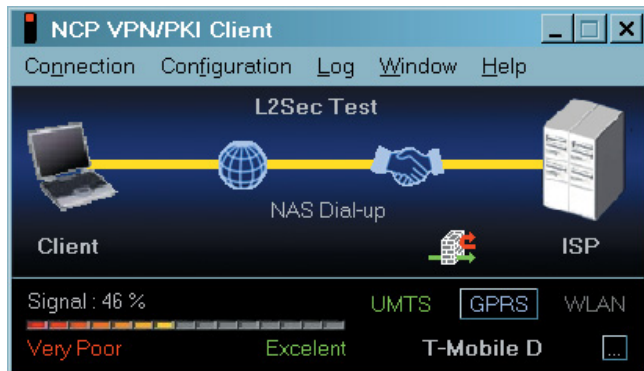

Then the connection will be reestablished automatically, if this is what has been configured for the connection setup in the phonebook.

## 4. Domain Login via NCP Gina



The Client software starts in background in the boot phase and captures the call “Ctrl-Alt-Delete”.

The integrated Personal Firewall provided by the NCP software is already active at this time, so that the PC is already protected.

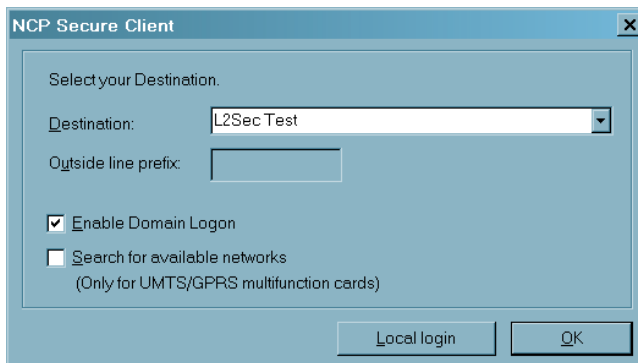

The destination system that has been configured for the connection medium GPRS/UMTS can be selected during the boot phase.

(The function “Activate domain login” is only required if there was previously an incorrect logoff! The search for available alternative networks takes a few seconds and is usually only significant abroad.)

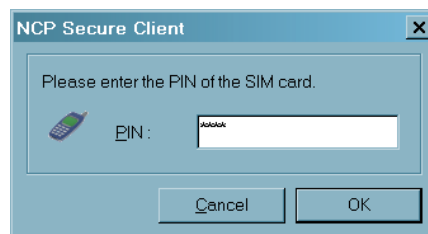

The SIM PIN must then only be entered if it has not yet been entered in the configuration of the destination system (profile) in the “Modem” parameter field in the telephone book or if the saved PIN does not agree with SIM you are using.

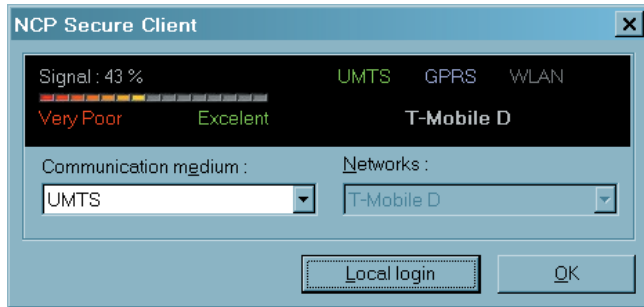

Then the signals of the card will be displayed, after the network search the wireless network found is shown with the respective field strength.

If search for alternative networks has been activated, then a different network as well as a different connection medium can be selected manually.

Then click on “OK” in order to continues with domain login.

(Use “Local login” to exit the domain login dialog.)

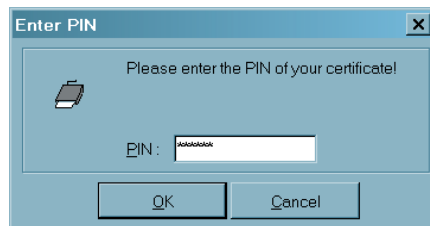

If use of the certificate has been configured for this connection, then at this point its PIN must be entered.

Then click on “OK”.

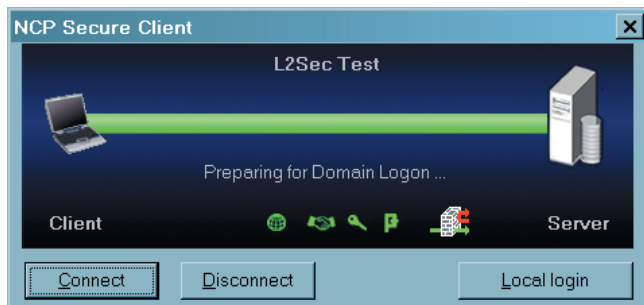

This establishes the connection and a tunnel into the central corporate network is setup.

Further procedure depends on the configuration in the Monitor menu under “Configuration / Logon options”.



1. The user enters the request login data as in the standard Windows login (see “Standard Windows login” in the Fig. below)

2. The Client software transfers the requested login data into this screen (the MS0GINA) automatically, so that the user does need to enter anything else for the Windows login. For this “Use saved login data” must be activated in the logon options, and the data must be entered in the fields.

## 4.1 Logon Options

The logon options are selected via the “Configuration” Monitor menu.



Please note the descriptions in your handbook of the client about possible settings in this windows.

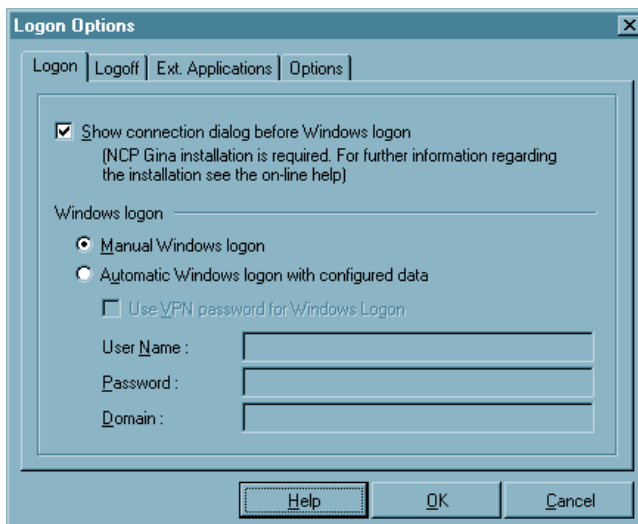

In this window you can decide wether via “the connection dialog before Windows logon” on a remote domain the connection from the client to the gateway should be established. For connection setup to the gateway it may be necessary to enter the PIN for the certificate, as well as for the SIM card, and the (non-saved) password for network dial-in prior to entering the password for the Windows login.



If the connection setup takes place prior to the Windows logon, then the login to the remote domains will be encrypted.

If you use the logon option with callback, then “Negotiate PPP callback” must be executed (see →“Callback”).

The computer must be rebooted after every change of logon options made in the Monitor.



This function can only be activated with administrator rights!

## 5. Log Files

If a multi-function card for UMTS/GPRS is installed, then a log file is written in the log directory of the Secure Client, with the following columns:

1st Column: Time

2nd Column: Current field strength

3rd Column: Average field strength of the last minute

4th Column: Average field strength of the last 5 minutes

5th Column: Average field strength of the last 10 minutes

6th Column: Current network type (UMTS or GPRS)

7th Column: Current network

An entry is created every 10 seconds; however the entries are only written to the file every 5 minutes.

A log file is created with the name “mfc<DATE>.log” for each day.

The log files for the last 7 days are saved.



*For your notes →*

Appendix to the  
NCP Secure Enterprise Client and NCP Secure Entry Client:

## Services and Applications of the Secure Client



Network  
Communications  
Products engineering GmbH

GERMANY  
Headquarters  
Dombühler Str.2  
D-90449 Nürnberg  
Tel.: +49-911-9968-0  
Fax: +49-911-9968-299  
internet [http:// www.ncp.de](http://www.ncp.de)  
E-mail: [info@ncp.de](mailto:info@ncp.de)



# Contents

<b>1. Services and Applications of the Secure Client</b>	<b>A27</b>
1.1 Overview of the ports of the NCP Secure Client	A30
for Win2000/XP:	A30
for 98/ME:	A30
additional ports:	A30
1.2 Registry Entries for the NCP Secure Client	A31
Key: Software\Ncp Engineering GmbH\NCP RWS/GA\6.0	A32
Key: Software\Ncp Engineering GmbH\NCP Secure Client	A32
<b>2. rwsrsu.exe – Update Client</b>	<b>A33</b>
2.1 Functional Description	A33
2.2 Configuration	A34
2.2.1 Configuration of the Update Client (rwsrsu)	A35
Configuration compare via the Management Server	A35
Update Interval (CheckInterval):	A35
Block Size (BlockSize):	A35
Additional Configuration Settings in the Registry	A35
2.2.2 Automating the Initial Logon	A37
Example	A37
2.2.3 Configuration on the Management Server (ncprsu.exe)	A39
2.2.4 Management Server / Settings	A40
[General]	A40
[Clients]	A44
[Authentication]	A45
[ClientAuthentication]	A46
[CONNMAN]	A47
[CMP]	A47
[RADIUS]	A48
[Log]	A48
[Syslog]	A49
[Console]	A49
2.2.5 Update of the Update Client	A50
<b>3. ncpbudget.exe – Budget-Manager (Connection Management/Statistics)</b>	<b>A51</b>
<b>4. rwscmd.exe – Command Line Interface</b>	<b>A52</b>
4.1 Transferring Commands to the NCP Secure Client	A52
4.2 Prerequisite for Program Use	A53
4.3 Description of the Commands	A53
<b>5. ncprwsnt.exe</b>	<b>A56</b>
connect.bat	A56
disconnect.bat	A56



# 1. Services and Applications of the Secure Client

The services `ncpsec.exe`, `ncprwsnt.exe`, and `rwsrsu.exe` can be called from the Windows system service overview (accessed via the Windows start menu under “Control Panel – Administrative Tools – Services”, the NCP services are highlighted in the Fig. below).

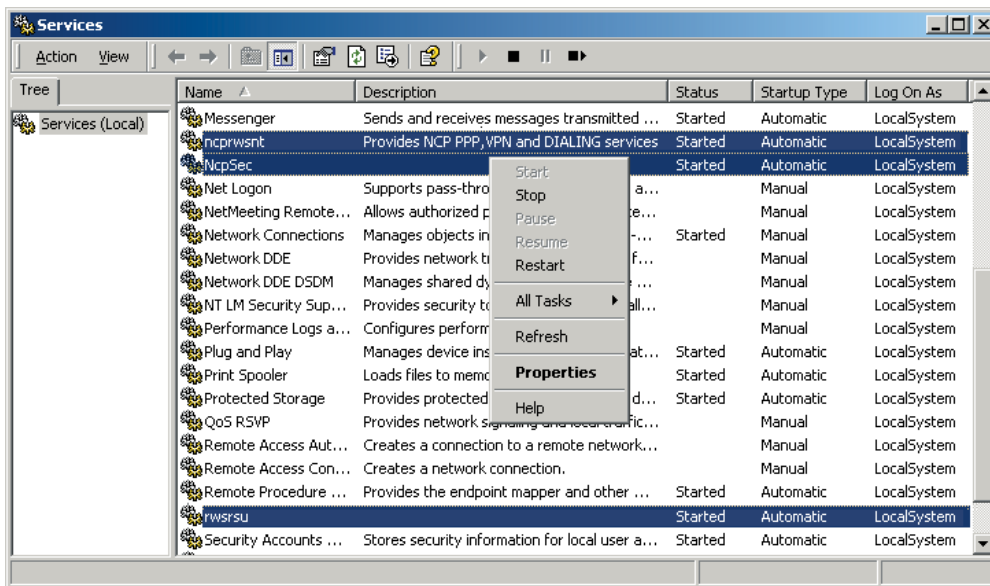

You can view the properties of these services from this Windows screen, or you can start or stop the services.

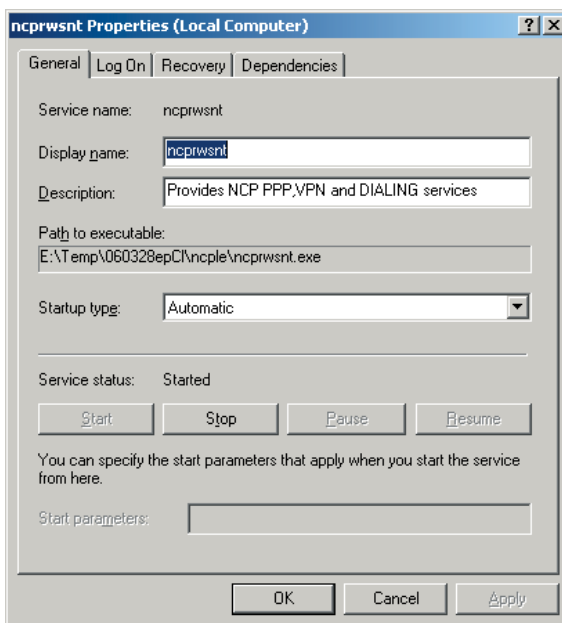

All services of the Secure Client are started automatically from the installation directory after the software is installed.



In addition to the services there are also applications in the installation directory:

### ncptrew.exe

```

Tracer
Go
Tue Jan 10 09:24:22 2006:Ncp Secure Client SystemInit
RWSGA installation path - C:\WINNT\ncple
RWSGA phonebook - C:\WINNT\ncple\ncpphone.ctg
RWSGA DeniVersion - 0
Tue Jan 10 09:24:26 2006:NCPiKE:initialized successfully
AdapterInit:Index(0),MediaType(0),Mtu(1300),Dhcp(0),Passthru(0),IpAdri(000.000.000.000.),MacAdri(PHLP: NcpleDir - C:\WINNT\ncple\ncpphone.ctg)
RwsGaAdapter:version_info(verbt:Secure Client Professional Version 8.05)
RwsGaAdapter:version_info(softver:1)
AdapterConfig(rwspdm:3)
AdapterConfig(rwsp_o_isdn:0)
AdapterConfig(rwsp_o_asyn:0)
CardReadConfig(1,type:2)
Tue Jan 10 09:24:27 2006:RawWin:port_init()
[API:Reading config from CAPI]
CAPI:Reading config success[2]
AdapterInit:Index(200),MediaType(0),Mtu(1500),Dhcp(0),Passthru(1),IpAdri(172.016.015.247.),MacAdri(00.04.7e.e3.05.2f)
Creating PASS THRU Adapter
+++ Pthru receive thread starting - (0181AF94).1
PthruAdapter:Ink PASS THRU Adapter TCP/IP -> 3Com EtherLink PCI
PthruAdapter:SystemName - \DEVICE\{6E863D1C-1E33-42A1-A07E-6C2C29C8232D}
Clear Trace Window
  
```

Trace-Monitor; can also be started via “Windows – Programs – Secure Client Tracer”. This is an autonomous application program for qualified system technicians. For example it can be used to create traces for troubleshooting purposes. The tracer is not intended for the normal user!

### ncpmon.exe

starts the Client Monitor; can be started by double clicking on the traffic light icon in the toolbar or via “Windows – Programs – Secure Client Monitor”. Monitor operation and menu prompts are described in detail in the manual for the respective Secure Client.

### ncpike9x.exe

IKE protocol for Windows 95/98

### ncpike.exe

IKE protocol for Windows 2000/XP

### lbtrace.exe

tracer on driver level for virtual NCP adapter

### inst95.exe

installation program for Windows 95/98

### insrnt5.exe

installation program for Windows 2000/XP

### uninst.exe

The Secure Client can be deinstalled with this program by bypassing the Windows software administration.

### 3monapl.exe

Field strength display for UMTS/GPRS when using a multi-function card.

### ncpauth.exe

is used for http authentication

### ncprwsnt.exe

Responsible for data communication frame processing via NCP PPP and VPN, as well as the dial services.

**rwsrsu.exe**

Update Client; corresponds to the program ncprsu.exe on the Management Server, see →below

**rwsrsuhlp.exe**

Help program for rwsrsu.exe; start it with:  
`rwsrsu -h`

**ncprndll.exe**

Is used by the Update Client and calls a DLL that stops or restarts the Client when there is an update.

**ncpbudgt.exe**

Budget Manager, see →below

**ncpmsg.exe**

Corresponds to the Budget Manager and if configured in the Client Monitor, it opens the message window with the appropriate warning for the user.

**rwsrmd.exe**

Command line interface, see →below

**ncppopup.exe**

Program for entering license data and viewing the software version information; it can be started via “Windows – Programs – Secure Client Popup”.

**ncpsec.exe**

PKI module of the Client software; this program is only necessary when using digital certificates. The configuration of smart card readers and soft certificates is described in detail in the respective Secure Client manual, in the “Monitor” section.

**ncpepsec.exe**

Module for endpoint security between the Secure Client and VPN Gateway; the policies for endpoint security are configured on the Secure Enterprise Management system with the plug-in “Endpoint Policy Enforcement”. Consequently Endpoint Policy Enforcement is only possible if NCP Secure Enterprise Management is implemented. The security policies of all endpoints of the components implemented can only be uniformly allocated to all endpoints with this central management tool. While the Endpoint Security Policies are output from the Enterprise Management system, download of the security policies (which the Management Server prescribes) must be activated on the

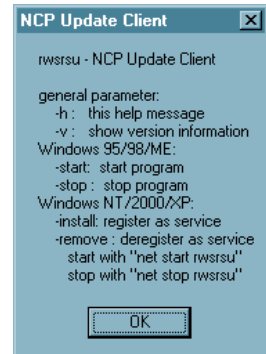



VPN Gateway. This is done on the Secure Server Manager in the configuration branch “Client Policy Enforcement”. If endpoint security is activated then the current policies are compared and downloaded via the program `ncpepsec.exe`.



The following services and applications are described in more detail below:

`rwsrsu.exe`  
`ncpbudgt.exe`  
`rWSCmd.exe`  
`ncprwsnt.exe`

## 1.1 Overview of the ports of the NCP Secure Client

*for Win2000/XP:*

<code>ncpmon.exe</code>	10544
<code>ncpsec.exe</code>	10522, 10542
<code>ncprwsnt.exe</code>	1701, 500, 10523, 10530, 10550, 10600, 10610
<code>rwsrsu.exe</code>	dynamic port after 12501 (Management Server)

*for 98/ME:*

<code>ncpmon.exe</code>	10544
<code>ncpbudgt.exe</code>	10522, 10542
<code>ncpike9x.exe</code>	1701, 500, 10523, 10530, 10550, 10600, 10610
<code>rwsrsu.exe</code>	dynamic port after 12501 (Management Server)

*additinal ports:*

<b>PKI</b>	10523
<b>PPPoE</b>	10550
<b>IPHlp</b>	10560
<b>WSUP (Driver)</b>	10600
<b>DNS Client</b>	10610

## 1.2 Registry Entries for the NCP Secure Client

The registry entries can be found under two directory paths with the registry editor:  
 Software\Ncp Engineering GmbH\NCP RWS/GA\6.0  
 and

Software\Ncp Engineering GmbH\NCP Secure Client  
 (see fig. below)

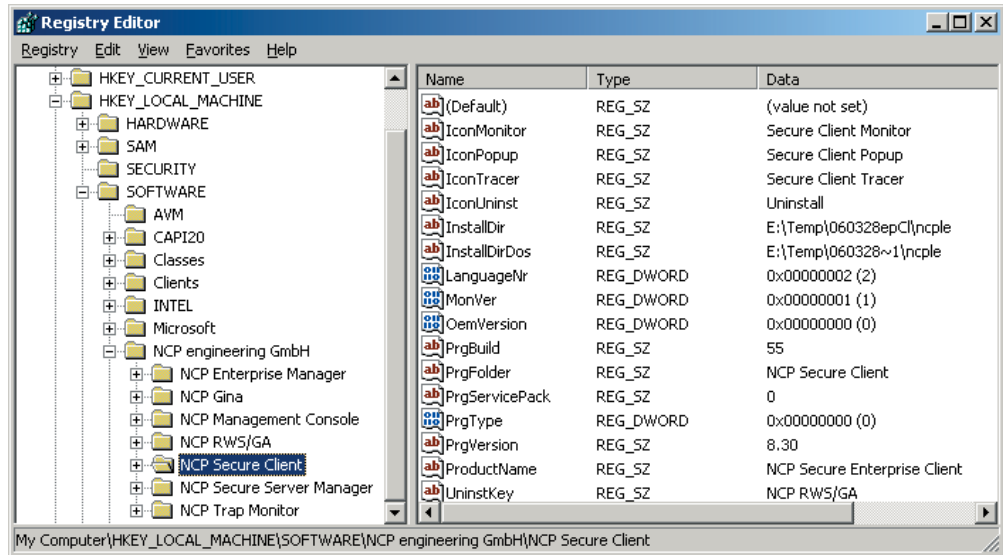

**Key: Software\Wcp Engineering GmbH\WCP RWS/GA\6.0**

**SeClCsi**                      DWORD  
Secure Client Connection state Information

**Key: Software\Wcp Engineering GmbH\WCP Secure Client**

**InstallDir**                 STRING  
Installation directory

**ProductName**             STRING  
Name of the product e.g: NCP Secure Client

**OemVersion**              DWORD  
0=Ncp,  
2=T-Online,  
4=Dlink,  
5=LanCom,  
6=Bintec

**DisableRws**              DWORD  
1=Client is inactiv,  
0=Client is activ

**PrgFolder**                STRING  
Name des start menu

**PrgVersion**               STRING  
Version as string  
z.B. 8.01

**IconMonitor**             STRING  
Menu name of the monitor

**IconPopup**               STRING  
Menue name of the popup

**IconTracer**              STRING  
Menue name of the tracer

**MonVer**                   DWORD  
???

**UninstKey**                STRING  
Name for deinstalltion key in the registry

## 2. rwsrsu.exe – Update Client

The service `rwsrsu.exe` is used for communication between Secure Client and Enterprise Management (formerly Update Server) and functions as Update Client. Use `rwsrsu.exe` to trigger an automatic update of soft certificates, configurations, and software.

### 2.1 Functional Description

The Secure Client and Enterprise Management (formerly Update Server) are compared for each encrypted VPN connection of a Secure Client to the NCP Secure Server. (This Update Service cannot be used for pure dial-in connections!)

If an Enterprise Management Server (Update Server) is installed and the appropriate configuration is executed, then the NCP Secure Server (VPN Gateway) sends the IP address of the Management Server (Update Server) to the Client, after authenticating the Client. If the Update Client has been configured accordingly (see the registry entries below) then an extended log output is generated in which the IP address of the Management Server can be located under the entry, PRIDLS (Primary Download Server). If the NCP Secure Enterprise Management Server is installed behind an external VPN gateway, then its IP address must be saved in the Phonebook of the Secure Client (under “DNS/WINS – Management Server”).

Then the Client’s `rwsru` service contacts the Management Server (Update Server) to execute a version compare. This is done after each restart of the Secure Client for the first VPN connection to the central gateway (at least).

As soon as the `rwsrsu` service detects that a newer version is ready for the Secure Client, then depending on the configuration a new software program, an updated configuration (Phonebook), a PKCS#12 file (soft certificate), as well as CA certificates, are transmitted to the Secure Client.

In this process a Phonebook or a certificate is updated depending on the VPN user ID that is used on the Client. Here you can specify whether each user will receive an individual directory for stored configurations, or whether a general directory will be referenced for all VPN users for this purpose. The latter option however is only available in conjunction with certificates.

## 2.2 Configuration

The Management Server, as well as the Update Client (NCP Secure Client) can be set especially for communication to each other.

If configurations are executed then the service, i.e. the program must first be stopped and then restarted so that the changes become effective.

for Management Servers with:

```
net stop ncprsu  
net start ncprsu
```

for the Update Client under Windows NT/XP/2000 with:

```
net stop rwsrsu  
net start rwsrsu
```

for the Update Client under Windows 98/ME in the directory installdir\ncple\ with:

```
rwsrsu /stop  
rwsrsu /start
```

## 2.2.1 Configuration of the Update Client (rwsrsu)

### ■ Configuration compare via the Management Server

The rwsrsu (Remote Software Update) service that is always active on the Secure Client is first set by the Management Server. The Update Client receives the Update interval for this and the block size for the compare. These data are transmitted from the configuration of the Management Server to the Client when it (the Client) logs on.

#### *Update Interval (CheckInterval):*

As delivered the setting for the update interval is one day. Use the update interval to specify a time period in seconds, after which the Secure Client or the RWSRSU will contact the Management Server, in order to check whether updated files are present.

#### *Block Size (BlockSize):*

The block size designates the maximum size (in bytes) of the data packets that will be transmitted. The block size should not exceed 64-kByte.

### ■ Additional Configuration Settings in the Registry

Additional settings for the Update Client can be made in the file ncpmon.ini under the header RWSRSU:

<b>Registry Entry</b>	<b>Meaning</b>
RsuPort	Port for TCP connection to the Management Server Standard is 1250 The port must agree with the RsuPort in the file NCPRSU.CONF on the Management Server.
RsuLogLevel	If this entry exists, then extended log outputs are generated in the file installdir\RWSRSU.LOG. Permitted values are 0 - 9.
RsuLogFileSize	Maximum size of the log file in bytes Standard is 200,000 bytes

## RsuAutoAnswer

This setting can also be changed with:

```
... \installdir\rwscmd\rwsautoanswer
```

If this entry is present then you can determine how the Update Client will handle the update when a software update is ready to be provided:

0 = off (standard)

The question as to whether an update should be executed is displayed for the user. The user selects yes or no.

1 = yes

All updates are executed automatically, without asking the user.

2 = no

The update will not be executed.

## 2.2.2 Automating the Initial Logon

For a rollout the initial logon (initialization logon) of the Client on the Management Server can be automated via batch files. User inputs that he gets from the information in the PIN letter, for example, can be transferred to a tool via appropriate parameters and batches, instead of interactively. Use the program `rwscmd.exe` (starting with Secure Client v. 7.21) for this automatic init user procedure, with the following commands:

```
rwscmd /setinituser <name> [<auth code>]
```

Writes the specified VPN user ID and the authentication code into the registry; the Update Client reads it from the registry.

```
rwscmd /rsuautoanswer <off | yes | no>
```

Notes the desired mode in the registry

off = Ask user whether a software update should be executed  
 yes = always execute software update  
 no = do not execute a software update

```
rwscmd /select [Destination Name]
```

Selects the specified Phonebook destination



In addition please note: After a successful init logon the Update Client checks whether the file `rsuinit.bat` is present in the installation directory. If this is the case, then it is automatically executed after the disconnect. Note that the complete path information (e.g. when calling `RWSCMD`) is strictly required as the standard path is not the installation directory.

### Example

A batch file for the initial logon with the “Multiple user” must be started manually and can look like the following:

STARTINIT.BAT

```
c:\installdir\rwscmd /setinituser <name> [<auth code>]
c:\installdir\rwscmd /rsuautoanswer yes
c:\installdir\rwscmd /connect [Destination Name]
```



The RSUINIT.BAT, which must bear precisely this name in order to be called automatically, can look like this:

#### RSUINIT.BAT

```
c:\installdir\rwscmd /rsuautoanswer off
c:\installdir\rwscmd /select [Destination Name]
c:\installdir\rwscmd /connect
del c:\installdir\rsuinit.bat
```

In order to execute an automated, non-interactive InitLogon, the following parameters must be written in ncp.ini with rwscmd.exe:

<b>Name</b>	<b>Meaning</b>
RsuInteractive	= 0 →automatic InitLogon. In this case the following 2 values are read.
RsuLogonUserId	the VPN user ID to be used
RsuLogonPw	Authentication Code (only necessary for LDAP Auth.)

### 2.2.3 Configuration on the Management Server (ncprsu.exe)

The Update Clients obtain the information relative to the IP address of the Management Server within the PPP negotiation when establishing the connection to the VPN Gateway. If the Management Server is installed behind an external VPN gateway then its IP address must be saved in the Phonebook of the Secure Client (under “DNS/WINS – Management Server”).

The computer with the Management Server must be reachable from the NCP Secure Server (VPN Gateway) per TCP/IP in the network.

If the Management Server is installed on the same computer as the Secure Server (VPN Gateway), then ensure that the IP address of the Management Server is not identical to the address of the tunnel endpoint that the clients use to set-up the tunnel. Otherwise the rwsrsu service would attempt to set-up a connection to the Management Server outside of the tunnel, a function that in most cases has already been suppressed by the Firewall.



The subsequent configuration of the Management Server is executed by editing configuration data in the main menu of the Management Console under “Management Server / Settings”.

## 2.2.4 Management Server / Settings

In the Management Console open “Settings” under the main menu option, “Management Server”.

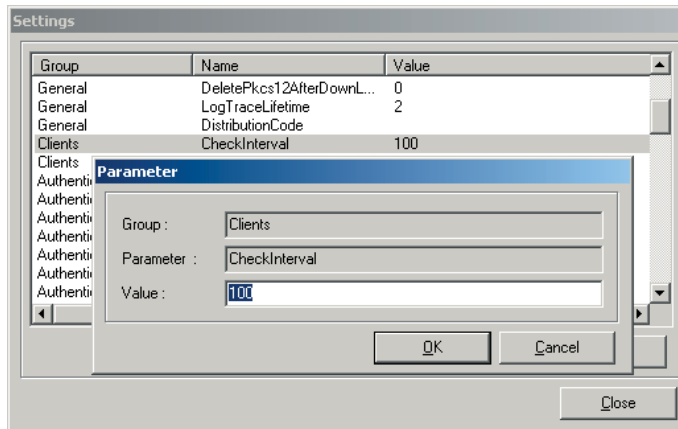

The parameters are ordered according to groups.

The values can be changed by double clicking on the appropriate parameters.



Please restart the Management Server after editing the parameter values so that the new configuration will be effective.

### [General]

**RsuPort** = 12501

(Standard = 12501) Must agree with the setting on the Update Client (see above →registry entry).

**MgmPort** = 12502

(Standard = 12502, sollte nicht verändert werden) management port through which the Client Manager sets the Phonebooks.

**MgmSSLPort** = 12504

(Standard = 12504, should not be changed) management port through which the Client Manager sets the Phonebooks via SSL.

**ReplPort** = 12505

(Standard = 12505, should not be changed) management port through which the Management Server creates a backup.

**ReplDBPort** = 12506

(Standard = 12506, should not be changed) management port through which the Client Manager replicates the database.

**MaxSessions** = 50

Number of Client sessions that the Management Server will process concurrently. A maximum of 200 Client sessions are possible.

**PrimaryIPAddr** = 127.0.0.1

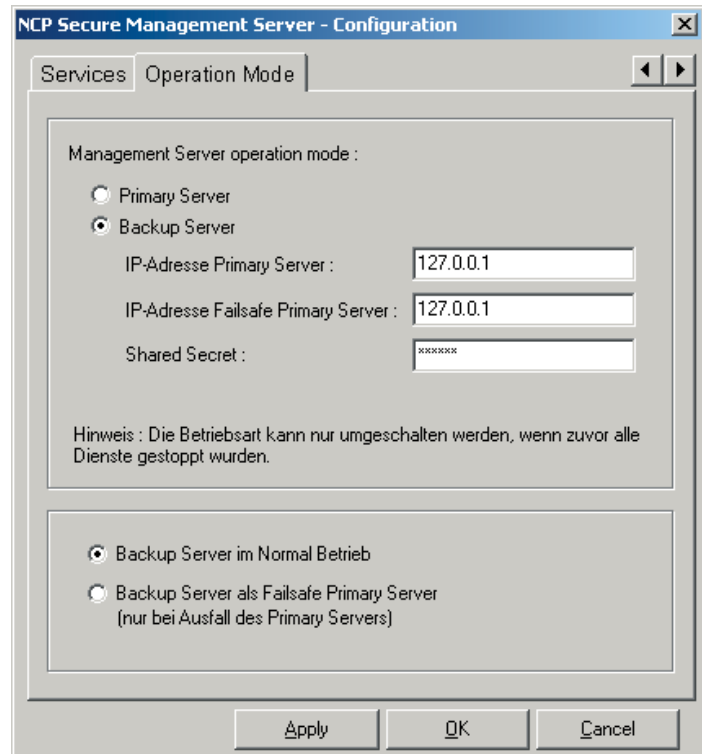

If the Management Server is used as Backup Server, then the IP address of the primary server is specified here. This configuration is made in the Windows start menu prior to starting the Management Server, under “NCP Management Server – Configuration” (see fig. above).

**ServerType** = 0

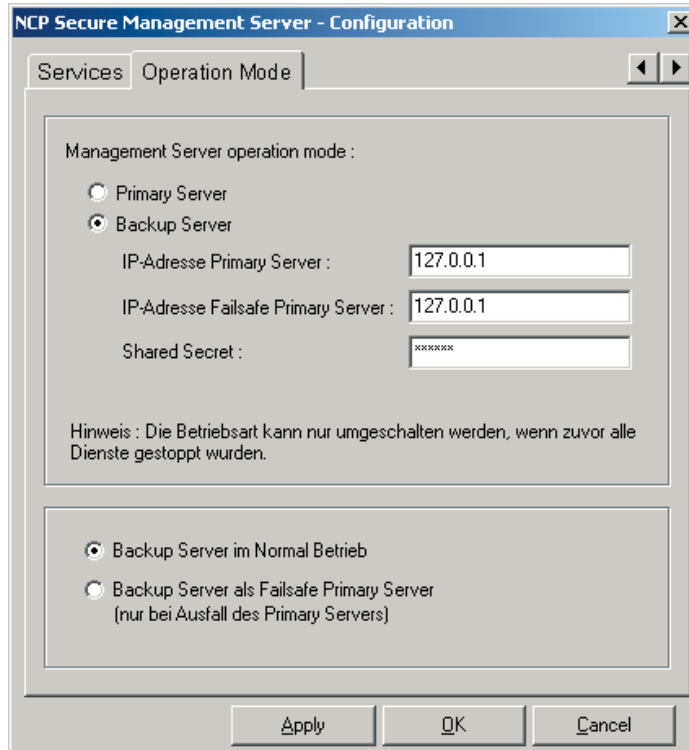

0 = Management Server is used as primary Server

2 = Management Server is used as backup Server

This configuration (under Windows) is made prior to starting the Management Server in the Windows start menu under “NCP Management Server – Configuration” (see fig. above).

### **ReplSecret**

If the Management Server is used as Backup Server then the “Shared Secret” is entered for the Primary Server. This configuration (under Windows) is made prior to starting the Management Server in the Windows start menu under “NCP Management Server – Configuration” (see Fig. above).

### **DeletePKCS12 AfterDownload**

= 0

Standard = 0; after a download the soft certificate is deleted from the database.

1 = the certificate is not deleted.

<b>LogTraceLifetime</b>	= 2	Number of days until the log entries are deleted.
<b>LogLevel</b>	= 9	(possible values = 0 - 9) With the value the depth of the analysis level is determined for the log file.
<b>LogFile</b>	= ncprsu	The file name of the log file: ncprsu.log
<b>LogPath</b>	= ./log	The directory underneath the installation directory where the log file is located: <Installationdirectory>\log\ncprsu.log
<b>LogFileSize</b>	= 2000000	This parameter entry is optional!  If the value of the log file entered here in bytes (standard = 2000000) is reached, then the current log file is renamed to <name>. old, a previous <name>.old is deleted.
<b>UseDefaultPhonebook</b>	= 0	This switch for the Phonebook selection can be used to specify whether the Management Server will make a uniform Phonebook available to all users, or whether it will make an individual phonebook available to each user.  UseDefaultPhonebook = 0 each user gets his individual phonebook  UseDefaultPhonebook = 1 each user gets the same phonebook
<b>InitUserId</b>	= inituser	This is where you enter the user ID for initial logon on the Management Server. This “initial” user ID for the rollout is the same for all Clients. Consequently the parameter “Allow multiple users” must be activated on the Secure Server for this user ID. If the Client dials in with this ID then the Management Server will send the request for entry of personal VPN user ID and password/ authentication code back to the

Client. Only after entry of the personal access data can the user receive a personalized Phonebook or soft certificate.

(If a Client logs on with this InitUserID, and if LDAP authentication is not configured, then the Client will only be asked for his VPN user ID. In this process the system checks whether a directory exists on the Update Server for this entered VPN user ID. If this is not the case then the logon will be rejected; the user will get another chance to enter a VPN user ID. Compare parameter “CheckUserDirAfterInitLogon”)

### **CheckUserDir AfterInitLogon**

= 1

This parameter entry is optional! (Standard = 1)

1 = For the first logon (InitLogon) without authentication code, with VPN user ID the system checks whether a directory exists for this new user. If this is not the case, e.g. for misspelled VPN user ID, the logon fails and the user is again requested to enter his VPN user ID.

0 = The logon is executed in such a manner that the system searches for a Phonebook or soft certificate for this user. If nothing is found then the following appears in the log window of the user Monitor: Configuration at current level.

## *[Clients]*

### **CheckInterval**

= 86400

The update interval is specified in seconds and as delivered the parameter is set to one day (86400 seconds). The update interval describes a time period in seconds, after which the Secure Client or the RWSRSU will contact the Management Server, in order to check whether updated files are present.

### **BlockSize**

= 20000

The block size designates the maximum size (in bytes) of the data packets that will be transmitted. The block size should not exceed 64 kByte (=65536). The Update Client compares its value with the block size for each connection with the Management Server.

**[Authentication]**

The complete configuration section under [Authentication] is used for rollout, if an LDAP Server is also available.

**UseLdapAuthentication** = 1

0 = LDAP authentication is not used

1 = LDAP authentication is used

If LDAP authentication is used, then the following parameter values must be used accordingly. These values must agree with those that have been configured with the Server Manager on the Secure Server (VPN Gateway) (see the Server Manual →LDAP Server)

**LdapHost** = 127.0.0.1

IP address of the LDAP host in the corporate network. (Corresponds to the parameter “LDAP Host” in the server manual.)

**LdapPort** = 389

The port number of the LDAP Server. Only change this value if the LDAP Server definitively runs under a different port number than the standard number specified here (389). (Corresponds to the parameter “Port | LDAP Host” in the server manual.)

**LdapAdminDN** = cn=xxx,o=xxx,c=xxx

This Distinguished Name (DN) indicates where the configuration for the administrator is located on the LDAP Server. (Corresponds to the parameter “Administrator DN” in the server manual.)

**LdapPassword** = xxx

The administrator password that enables access to the LDAP Server. (Corresponds to the parameter “Administrator | Password” in the server manual.)

**LdapBaseDN** = cn=xxx,o=xxx,c=xx

LDAP search path; the user-specific configurations of the link profiles for the Clients can be found on the LDAP Serv-



er below this search path. These Clients access the Management Server via the associated VPN Gateway (see above). The username is searched as Common Name (cn) under the LdapBaseDN.

**LdapAuthAttribute** = ncpUserAuthenticationCode

If the user ID is found, then the value entered in this attribute is allocated to this user ID as authentication code.

### *[ClientAuthentication]*

**AuthCodeMinLen** = 6

The minimum length of the authentication code. (Standard = 6)

**AuthCodeValidDays** = 14

This is used to specify the validity period of the authentication code in days after it has been generated.

**AuthCodeMaxErrCnt** = 10

This number determines how often the authentication code can be entered incorrectly. If the entered error number is reached, then the client can no longer dial in. It is only possible to cancel the disable via the Management Console.

**AuthCodeDisableRest** = 0; With configuration downloads the authentication code is reset. 1 = ... not reset.

**[CONNMAN]**

In this section the parameters are set for automatic update of the foreign phonebook for T-Online.

<b>URL</b>	= http://www.t-update.de/securevpn/phb.zip
	Phonebook file URL of the Connection Manager. (Check this entry in the configuration file.)
<b>Interval</b>	= 800000
	Time interval in which a new foreign Phonebook should be downloaded from T-Online. The time starts running after a Client requests a T-Online Phonebook for the first time.
<b>ProxyHost</b>	= xxx.xxx.xxx.xxx
	IP address of the HTTP Proxy Server, if necessary.
<b>ProxyPort</b>	= 80; Port of the Proxy Server.
<b>ProxyAuthName</b>	= User ID for the Proxy Server
<b>ProxyAuthPwd</b>	= Password for the Proxy Server

**[CMP]**

<b>CmpPort =</b>	829; CMP Listen Port.
	0 = CMP Server disabled
<b>CmpPollTime</b>	= 15; CMP polling interval in seconds
<b>LogLevel</b>	= 0
	CMP Log Level. (possible values = 0 - 9) The value determines the depth of the analysis level for the log file.

**[RADIUS]****Enabled** = 1

The integrated RADIUS Server of the Management System is activated with 1, and deactivated with 0.

**AuthPort** = 1812

Authentication Port (Standard = 1812, should not be changed)

**AccPort** = 1813

Accounting Port (Standard = 1813, should not be changed)

**LogLevel** = 0

RADIUS Log Level. (Possible values = 0 - 9) The value determines the depth of the analysis level for the log file.

**[Log]**

The value determines the depth of the analysis level for the log file. (Possible values = 0 - 9)

**LogLevel** = 0**SessLogLevel** = 0**MgmLogLevel** = 0**ReplLogLevel** = 0**PackageLogLevel** = 0**LogPath** = ./log

The path is specified with the directory for the log files.

Number of days until the log entries are deleted:

<b>LogLifetimeSecurity</b>	= 90
<b>LogLifetimeConfig</b>	= 90
<b>LogLifetimeLogins</b>	= 90
<b>LogLifetimeAdmin</b>	
<b>Logins</b>	= 90
<b>LogLifetimeSystem</b>	= 30
<b>LogLifetimeTasks</b>	= 90
<b>LogLifetimeTrace</b>	= 2
<b>LogLifetimeAccounting</b>	= 90
<b>LogLifetimeSyslog</b>	= 90
<b>LogLifetimeRadius</b>	= 90

### *[Syslog]*

<b>Hosts</b>	= 127.0.0.1; Syslog Server Hostname
<b>Port</b>	= 514; Syslog Destination Port (Standard = 514)
<b>Facility</b>	= 20000; Facility Base
<b>LogTrace</b>	= 0; Facility Base + 1
<b>LogConfig</b>	= 0; Facility Base + 2
<b>LogSecurity</b>	= 0; Facility Base + 3
<b>LogLogins</b>	= 0; Facility Base + 4
<b>LogAdminLogins</b>	= 0; Facility Base + 5
<b>LogSystem</b>	= 0; Facility Base + 6
<b>LogRadius</b>	= 0; Facility Base + 7
<b>ListenPort</b>	= 0; Standard = 514 0 = Listening disabled

### *[Console]*

<b>Console</b>	= 0; aus
<b>Console</b>	= 1; an

## 2.2.5 Update of the Update Client

A new Update Client is installed like a software package on the Management Server computer, by starting UpdRWSRSU2xx.exe.

The new Update Client files are stored in the database of the Management Server in the directory rwsrsu\v200\\* independent of the version number.

It is not necessary to restart the Management Server thereafter.

### 3. ncpbudget.exe – Budget-Manager (Connection Management/Statistics)

After installation of the Client Software the so-called Budget Manager runs automatically for connection management and statistics when the monitor starts.

The Budget Manager is responsible for monitoring Client software connections in accordance with precisely defined criteria.

These criteria are specified in the Monitor menu under “Configuration / Connection Management”. (See the manual for the Secure Client, Monitor, and Connection Management)

Activating Connection Management in the monitor menu is only practical if the connections are not routed to a corporate network gateway, or if charges are incurred for connection time or frequency of the connections. Otherwise charge management can be administered centrally.

If the Budget Manager is not used then it can be removed from the registry (see Fig. below). In this regard, note that it is automatically re-installed for an update or for a new installation. Thereafter it must be deleted again with regedit.

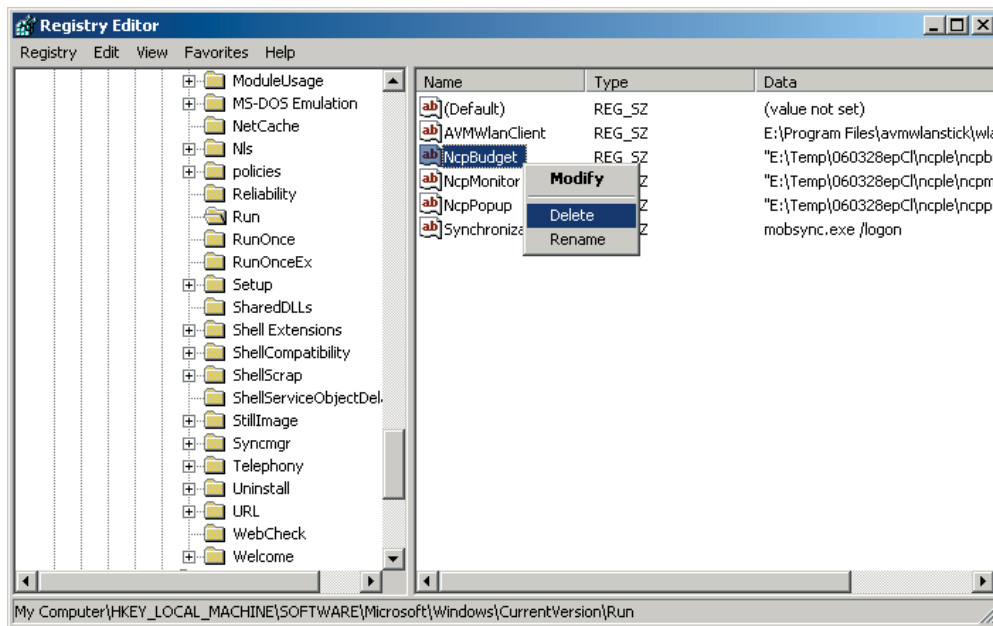

**Key:** `Software\Microsoft\Windows\CurrentVersion\Run\WCPBudget`

## 4. rws cmd.exe – Command Line Interface



Attention! The following description only applies for Windows systems.

### 4.1 Transferring Commands to the NCP Secure Client

With rws cmd.exe the NCP Secure Client (Entry/Enterprise/GovNet Client) has a command line interface that can be used for other applications. The prerequisite to use the rws cmd.exe program is Client software of at least version 7.0 (Enterprise Client) or 8.0 (Entry Client).

At installation the command line interpreter is copied into the ncple directory under Windows. It is called from this directory (e.g.):

```
C:\Windows\ncple>rws cmd /<Kommando>
```



If the syntax is not observed, or if a command is specified incorrectly, or incompletely, then a window will be displayed that lists the possible commands:

```
connect
connect [Destination Name]
disconnect
lock
unlock
start
stop
select [Destination Name]
setinituser InitUserId [Password]
rsuautoanswer off/yes/no
ginaon
ginaoff
ginainstall
ginauninst
logonhotspot [Timeout]
```

## 4.2 Prerequisite for Program Use

- The services `ncprwsnt`, `ncpsec`, and `rwsrsu`, must be started. These services start as a standard function after installation of the Client Software – they are located in the directory  
`C:\Windows\ncple>`
- It is only necessary to start the Monitor if passwords or PIN entries are required, since `rwsrscmd.exe` does not start a PIN dialog..
- In addition write authorizations must exist to the registry key:  
`KEY_LOCAL_MACHINE\Software\NCP engineering GmbH\NCP Enterprise Monitor`

## 4.3 Description of the Commands

```
rwsrscmd /connect
```

Required Windows authorization: User rights

Description: Connection setup with the last destination entry set in the Monitor.

```
connect [Destination Name]
```

e.g.: `rwsrscmd /connect "LAN via Router (IP)"`

Required Windows authorization: User rights

Description: Connection setup with the transferred destination entry.



Apostrophes are set instead of the square brackets. They are necessary because this is a transfer with spaces.

```
rwsrscmd /disconnect
```

Required Windows authorization: User rights

Description: Disconnects the current connection.

```
rwsrscmd /lock
```

Required Windows authorization: User rights

Description: Locks the Client, connection setup is no longer possible



```
rwscmd /unlock
```

Required Windows authorization: User rights

Description: Unlocks the Client, resets the lock that was set with Lock

```
rwscmd /start
```

Required Windows authorization: Administrator rights

Description: Starts all services, popup and monitor of the NCP Secure Client

If called again the message “Secure Client is already open” is displayed.

```
rwscmd /stop
```

Required Windows authorization: Administrator rights

Description: Stops all services, popup and Monitor of the NCP Secure Client

Also note that if the command `rwscmd /stop` has been executed then the command `rwscmd /start` must be executed thereafter, so that the services and the monitor can be restarted. In this case a reboot is not sufficient, as the popup and the monitor are not started.

```
rwscmd /select "Destination Name"
```

Required Windows authorization: User rights

Description: In the Secure Client the system goes to the desired destination.



Apostrophes are set instead of the square brackets. They are necessary because this is a transfer with spaces.

```
rwscmd /setinituser UserId "Passwort"
```

Required Windows authorization: Administrator rights

Description: If you do not want a window to be displayed for the initial connection, then the user ID, and optionally the password, can be transferred for the initial logon for the initprocess.



Apostrophes are set instead of the square brackets. They are necessary because this is a transfer with spaces.

```
rwscmd /rsuautoanswer off/yes/no
```

Required Windows authorization: Administrator rights

Description: This is where you set how the system will respond to queries for a software update.

- yes Client software automatically gets an update without query.
- no Automatic software update is rejected and not executed.
- off With the off setting the system asks (in a message window) whether the software should be updated.

```
rwscmd /ginainstall
```

Required Windows authorization: Administrator rights  
description: Installs the NCP Gina, if this has not yet occurred in the software installation (see the section “Installation” in the Client manual).

```
rwscmd /ginaunins
```

Required Windows authorization: Administrator rights  
Description: Deinstalls the NCP Gina. If an external Gina calls the NCP Gina, then deinstallation is not possible with this command. In this case it must be removed from the registry manually, or the Ginas must be deinstalled again in the reverse sequence (see the section “Logon options” in the Client manual).

```
rwscmd /ginaon
```

Required Windows authorization: Administrator rights  
Description: Switches the NCP Gina dialogs for logon to the VPN Gateway so that they are visible if the NCP Gina has been installed.

```
rwscmd /ginaoff
```

Required Windows authorization: Administrator rights  
Description: Switches the NCP Gina dialogs invisible and thus skips the VPN Gateway logon with the NCP Gina.

```
rwscmd /logonhotspot [Timeout]
```

If a hotspot logon will be executed via an external dialer, then the firewall can be released for ports 80 (HTTP) and 443 (HTTPS) with this command. This generates a dynamic rule that allows data traffic for this hotspot logon, until the transferred timeout (in seconds) has elapsed.



Because the firewall can thus be released via the command line, the parameter “Allow hotspot logon for external dialers” has been added under “Options” in the firewall settings. The command can only be executed via `rwscmd` if this parameter is active. (See → Configuration parameters / Phonebook, Firewall settings).

## 5. ncprwsnt.exe

Responsible for data communication frame processing via NCP PPP and VPN, as well as the dial services.

Applications which need system rights can be started with this service automatically after a connect or a disconnect. For that purpose two batch files in the installation directory have to be edited:

### **connect.bat**

This batch file includes the executable programs or batch files which should be executed after a connect.

### **disconnect.bat**

This batch file includes the executable programs or batch files which should be executed after a disconnect.



Note the parameter "Deny the start of the (dis)connect.bat". It is located in the monitor menu "Call Control Manager / Ext. Applications" under the item "Configuration".



This function should always be activated, exceptionally the execution with of one of the batch files administrator rights is absolutely necessary.

Applications (batch files) which require only user rights can be started via this monitor menu "Configuration / Call Control Manager / Ext. Applications" by entering their names (see →Client Monitor / Call Control Manager).

# Index

3DES	153
802.1x	98

## A

access data from configuration	159
AES 128, AES 192, AES 256	153
AES-128	192
AES-192	192
AES-256	192
Analog Modem	22
Analogue Interface	205
APN	143
Applications, Firewall	80
ARL (Authority Revocation List)	200
Authentication	153, 155
authorityKeyIdentifier	60, 167, 199, 200
Automatic detection of Friendly Nets	82
Automatic Media Detection	24, 134
Automatic mode	149
AVM - PPP over CAPI	23

## B

Basic locked settings	73
Basic open settings	73
Baud Rate	142
Blowfish	153
Blowfish 124 or 448	55
Bluetooth	22
Broadband Device	23

## C

CA Certificate	58
Call Control	97
Call Control Manager	96
Call Control Reset	64
Call Control Statistics	64
CDP (Certificate Distribution Point)	60
Certificate Authority	56
Certificate Extensions	199
Certificate renewal	95
Certificates	56
Certificates, Configuration	90
Certification Authority	56, 90
Client Certificate	57
Client Logon	174
COM Port	142
Communication medium	131
Compression	55
Configuration Locks	102
Connect	53, 171
Connection Info	54
Connection Mode	171

Connection type . . . . .	131
CRL (Certificate Revocation List) . . . . .	200
<b>D</b>	
Default Gateway . . . . .	32, 36
deflate compression . . . . .	155
Destination phone number . . . . .	137
Destination phone number, alternate . . . . .	138
DH Group . . . . .	153
DHCP (Dynamic Host Control Protocol) . . . . .	32, 36
Dial Prefix . . . . .	143
Diffie-Hellmann . . . . .	192
Disable Firewall . . . . .	73
Disconnect . . . . .	53
Display CA Certificate . . . . .	56
Displaying ACE Server Messages . . . . .	62
DNS/WINS . . . . .	161
Domain Name . . . . .	161
DPD (Dead Peer Detection) . . . . .	156
<b>E</b>	
EAP Authentication . . . . .	147
EAP MP5 . . . . .	98
EAP Settings . . . . .	98
EAP Status . . . . .	49
Encryption . . . . .	153
Endpoint Policy . . . . .	48
Establishing a Connection . . . . .	171
Exch. Mode . . . . .	156
Extended Authentication . . . . .	194
Extended Authentication (XAUTH) . . . . .	158, 176
Extended Authentication Protocol . . . . .	98
extendedKeyUsage . . . . .	60, 167, 199, 200
Extension checks . . . . .	60
extension, certificate . . . . .	60, 167
External Applications . . . . .	96, 100
External Dialer . . . . .	133
<b>F</b>	
Fingerprint . . . . .	56
Firewall Option . . . . .	48
Firewall Settings . . . . .	70, 187
Firewall, Basic Settings . . . . .	72
Firewall, Logging . . . . .	84
Firewall, Options . . . . .	83
Friendly Net Detection . . . . .	49
Friendly Networks, Firewall . . . . .	81
<b>G</b>	
Gateway (IPSec) . . . . .	149
GPRS . . . . .	22, 132
GPRS/UMTS . . . . .	23
GSM . . . . .	22
<b>H</b>	
Hardware Certificate . . . . .	57
Hash . . . . .	153
Hash   IKE-Richtlinie . . . . .	153
HotSpot Logon . . . . .	53
HSCSD . . . . .	23
HTTP authentication . . . . .	147

HTTP Authentication Script . . . . .	140
HTTP Logon . . . . .	139

**I**

ID   Identität . . . . .	158
Identity . . . . .	158
IKE Config Mode . . . . .	161, 196
IKE Policy . . . . .	149, 152, 188
IKE-Richtlinie . . . . .	152
Inactivity Timeout . . . . .	145
Incoming Certificate . . . . .	58
Incoming Certificate's subject . . . . .	165
IP compression (LZS) . . . . .	156
IPCOMP (LZS) . . . . .	193
IPSec Policy . . . . .	150, 154, 188
IR (infrared) interface . . . . .	22
ISDN . . . . .	55, 131
Issuer Certificate . . . . .	56
Issuer's certificate fingerprint . . . . .	166

**K**

Key exchange . . . . .	55
------------------------	----

**L**

LAN adapter . . . . .	23
LAN over IP . . . . .	55
License Data and Activation . . . . .	111
Licensing . . . . .	27
Line Management . . . . .	144
Link Firewall . . . . .	169
Link to Corporate Network using IPSec . . . . .	68, 131
Link to the Internet . . . . .	68, 131
Logbook . . . . .	105
Logon Options . . . . .	99
Lokales System . . . . .	28
LZS . . . . .	55, 155

**M**

MD5 . . . . .	193
MD5 (Message Digest, version 5) . . . . .	153
Media Type . . . . .	55
Microsoft RAS-Dialer . . . . .	135
Microsoft's dialer . . . . .	170
Mobile (cellular) telephones . . . . .	22
Modem . . . . .	55, 141, 142
Modem Init. String . . . . .	143
Multifunction Card . . . . .	23
Multilink . . . . .	55
Multilink Threshold . . . . .	146

**N**

NAT Traversal . . . . .	161
NAT-T (NAT Traversal) . . . . .	196
NCPPI.CONF . . . . .	26
NetBios over IP . . . . .	170
NetBIOS über IP zulassen . . . . .	170
NetKey 2000 . . . . .	26
Network addresses . . . . .	163

**O**

Offline Activation . . . . .	118
Online Activation . . . . .	116
Outside Line PrefixSettings . . . . .	89

**P**

Password	137, 159, 175
PFS (Perfect Forward Secrecy)	193
PFS group	156
PIN	61
PIN Handling	62
PIN Policy	95
PIN request	94
PIN state	62
PIN State Symbol	62
PIN, change	63
PIN, reset	62
PKCS#11	26
PKCS#11-Module	91, 93
PKCS#12	26
PKCS#12 File	91, 93
Policy editor	151
Policy lifetimes	150
Policy Name	153, 155
PPP Multilink	22, 146
PPTP	132
Pre-shared Key	149, 158
Profile Import	103
Profile name	131
Profile Settings	67, 128
Profile Settings Backup	104
Protocol, Firewall	76
Protocol, IPSec Policy	155
proxy-configuration	53

**R**

RAS script file	138
Release Com Port	142
RSA Signature	149
Rx	55

**S**

SA Negotiation	188
Seamless re-keying	193
Search new Updates	112
Security	185
Serial Number	56
Serial Number, Certificate	56, 57
SHA (Secure Hash Algorithm)	153
SHA1	193
SHA1 fingerprint	166
Signtrust	26
SIM PIN	143
Slotindex	26
Smart Card	26, 91
Smart Card Reader	25, 92
Soft Certificate	26
Software Activation	115
Speed	54
Stateful Inspection	169, 201
Stateful Packet Inspection	71
subjectKeyIdentifier	60, 167, 199, 200
Subnet masks	163

**T**

Test Version Validity Period . . . . .	114
Time Online . . . . .	54
Timeout . . . . .	54, 145
TLS . . . . .	98
Token . . . . .	26
Transformation (Comp) . . . . .	155
Tx . . . . .	55
<b>U</b>	
UDP Encapsulation (Port 4500) . . . . .	156
UMTS . . . . .	132
Upgrade to the Secure Enterprise Client . . . . .	43
User Certificate, Configuration . . . . .	91
Username . . . . .	137, 159, 175
<b>V</b>	
v.110 . . . . .	22
Validity . . . . .	56, 57
View Client Certificate . . . . .	56
View Incoming Certificate . . . . .	56
View Issuer Certificate . . . . .	56
<b>W</b>	
WAN domain logon . . . . .	174
WLAN . . . . .	85, 133
WLAN adapter . . . . .	24
WLAN adapter under Windows 2000/XP . . . . .	24
WLAN adapter under Windows 98/NT . . . . .	23
WLAN networks . . . . .	85
WLAN Profiles . . . . .	86
<b>X</b>	
X.509 . . . . .	25
XAUTH protocol . . . . .	196
xDSL . . . . .	23, 132
xDSL (AVM - PPP over Capi) . . . . .	55, 132
xDSL (PPPoE) . . . . .	55, 132



